

SUDOKU UNIT

JUFARINA BINTI JOLKIPLI

This report is submitted in partial fulfillment of the requirements for the award of
Bachelor of Electronic Engineering (Industrial Electronics) With Honours.

Faculty of Electronic and Computer Engineering
Universiti Teknikal Malaysia Melaka

Mei 2008



UNIVERSITI TEKNIKAL MALAYSIA MELAKA
FAKULTI KEJURUTERAAN ELEKTRONIK DAN KEJURUTERAAN KOMPUTER

**BORANG PENGESAHAN STATUS LAPORAN
PROJEK SARJANA MUDA II**

Tajuk Projek : SUDOKU UNIT

Sesi Pengajian : 2007 / 2008

Saya **JUFARINA BINTI JOLKIPLI**

mengaku membenarkan Laporan Projek Sarjana Muda ini disimpan di Perpustakaan dengan syarat-syarat kegunaan seperti berikut:

1. Laporan adalah hakmilik Universiti Teknikal Malaysia Melaka.
2. Perpustakaan dibenarkan membuat salinan untuk tujuan pengajian sahaja.
3. Perpustakaan dibenarkan membuat salinan laporan ini sebagai bahan pertukaran antara institusi pengajian tinggi.
4. Sila tandakan () :

SULIT*

(Mengandungi maklumat yang berdarjah keselamatan atau kepentingan Malaysia seperti yang termaktub di dalam AKTA RAHSIA RASMI 1972)

TERHAD*

(Mengandungi maklumat terhad yang telah ditentukan oleh organisasi/badan di mana penyelidikan dijalankan)

TIDAK TERHAD

Disahkan oleh:

(TANDATANGAN PENULIS)

Alamat Tetap: NO.305, JLN ABG GALAU,
KPG DATUK,
97000, BINTULU, SARAWAK.

Tarikh: 09/ 05 / 2008

(COP DAN TANDATANGAN PENYELIA)

PROFESOR ABDUL HAMID B HAMIDON
Profesor

Fakulti Kej Elektronik dan Kej Komputer (FKEKK),
Universiti Teknikal Malaysia Melaka (UTeM),
Karung Berkundi 1200,

Tarikh: Ayer Keroh, 75450 Melaka

DECLARATION

“I hereby declare that this report is the result of my own work except for quotes as cited in the references.”

Signature : *Jufarina*
Author : JUFARINA BINTI JOLKIPLI
Date : 09 MAY 2008

SUPERVISOR APPROVAL

“I hereby declare that I have read this report and in my opinion this report is sufficient in terms of scope and quality for the award of Bachelor of Electronic Engineering (Industrial Electronics) With Honours.”

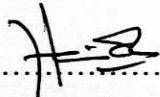
Signature : 

Supervisor Name : Prof. Abdul Hamid Bin Hamidon

Date : 09 MAY 2005

PROFESOR ABDUL HAMID B HAMIDON
Profesor
Fakulti Kej Elektronik dan Kej Komputer (FKEKK),
Universiti Teknikal Malaysia Melaka (UTeM),
Karung Berkunci 1200,
Ayer Keroh, 75450 Melaka

DEDICATION

Dedicated with deepest love to:

My beloved family for their support and guidance.

All of my fellow friends who stood there for me in what ever circumstances.

ACKNOWLEDGEMENT

Alhamdulillah, praise to Allah SWT that I had finally complete this bachelor report project within the time given. First of all, I would like to thank my supervisor, Prof. Abdul Hamid bin Hamidon for his supervision during completing this project. I also want to thank all my lecturer that have taught me at Universiti Teknikal Malaysia Melaka.

Not to forget, to all my friends and family for always be there whenever I am in trouble and encouraging me.

Therefore, I end this acknowledgement with only two words “Thank You”

ABSTRACT

Sudoku is 81 squares, which are arranged in 9x9 formats containing a selection of digits and blank. The grid consists of several regions which are row, column, and 3x3 regions. Each of the row, column and 3x3 regions must contain all number 1 to 9. The aim of this project is to build a Sudoku Unit using PIC16F877 Microcontroller, the keypad and the 7-segment display or the LCD display. This PIC16F877 acted as a connector between keypad and 7-segment display or LCD display. The keypad communicates with the PIC microcontroller and the PIC sending the data to the 7-segment display or LCD display. The communication between keypad and 7-segment or LCD is by using C language program that burnt in the PIC16F877. At the end of the project a simple display unit is made available for playing sudoku

ABSTRAK

Permainan Sudoku terdiri daripada 81 kotak yang disusun secara 9x9. Ia mengandungi petak kosong dan juga berdigit. Setiap grid mengandungi beberapa bahagian yang terdiri daripada baris, lajur dan 3x3 bahagian. Setiap baris, lajur dan 3x3 perlulah mengandungi nombor 1 sehingga 9. Tujuan projek ini adalah untuk membina sebuah permainan sudoku dengan menggunakan PengawalMikro PIC16F877, papan kekunci dan paparan 7 segmen/ paparan LCD. PengawalMikro PIC16F877 bertindak sebagai pengantara komunikasi antara papan kekunci dengan paparan 7 segmen/paparan LCD. Papan kekunci akan berkomunikasi dengan PengawalMikroPIC16F877 dan akan dihubungkan dengan paparan 7 segmen/ paparan LCD. Komunikasi antara papan kekunci dengan paparan 7 segmen/ paparan LCD dibuat dengan menggunakan Bahasa C yang akan dibakar didalam PengawalMikro PIC16F877.

CONTENT

| CHAPTER | TITLE | PAGE |
|-----------|-----------------------------|------|
| | PROJECT TITLE | I |
| | PROJECT APPROVAL | II |
| | DECLARATION | III |
| | SUPERVISOR APPROVAL | IV |
| | DEDICATION | V |
| | ACKNOWLEDGEMENT | VI |
| | ABSTRACT | VII |
| | ABSTRAK | VIII |
| | TABLE OF CONTENT | IX |
| | LIST OF TABLES | XII |
| | LIST OF FIGURES | XIII |
| | LIST OF ABBREVIATION | XV |
| | LIST OF APPENDICES | XVI |
| I | INTRODUCTION | |
| | 1.1 OVERVIEW | 1 |
| | 1.2 OBJECTIVE | 2 |
| | 1.3 SCOPE OF WORK | 2 |
| II | LITERATURE REVIEW | |
| | 2.1 HISTORY OF SUDOKU UNIT | 4 |
| | 2.2 BASIC SUDOKU CONCEPT | |

| | | |
|------------|--|-----------|
| 2.3 | INPUT | 10 |
| | 2.3.1 KEYPAD | 10 |
| | 2.3.1.1 Basic Hardware | 11 |
| | 2.3.1.2 Basic Approach For Scanning | 12 |
| 2.4 | DISPLAY | |
| | 2.4.1 9 X 9 Matrix Display | 13 |
| | 2.4.1.1 A Seven-Segment L.E.D. Display | 15 |
| | 2.4.2 LCD Display | 17 |
| | 2.4.2.1 Passive-Matrix Addressed LCDs | 18 |
| 2.5 | INTERFACE | 20 |
| | 2.5.1 PIC16F877A | 20 |
| 2.6 | KEYPAD SCANNING | 23 |
| 2.7 | GENERATING AN INTERRUPT | 24 |
| | 2.7.1 Short between Pins of the Output Port | 25 |

III**PROJECT METHODOLOGY**

| | | |
|------------|--|-----------|
| 3.1 | INTRODUCTION | 26 |
| 3.2 | HARDWARE DEVELOPMENT | 26 |
| | 3.2.1 The Voltage Supply | 26 |
| | 3.2.2 Basic Circuit For PIC16F877A | 27 |
| 3.3 | SOFTWARE DEVELOPMENT | 28 |
| | 3.3.1 Proteus | 28 |
| | 3.3.1.1 Working with Microprocessor | 30 |
| | 3.3.1.2 Debugging the Program in Proteus | 31 |
| | 3.3.2 Sourceboost | 34 |
| | 3.3.2.1 SourceBoost Architecture | 34 |
| | 3.3.2.2 User Interface | 35 |
| | 3.3.2.3 Project Workspace and Output Window | 35 |
| | 3.3.2.4 Project Wizard | 39 |
| 3.4 | SOFTWARE DEVELOPMENT | 42 |

| | |
|---|----|
| RESULT | 43 |
| 4.1 INTRODUCTION | 43 |
| 4.2 RESULT | 43 |
| 4.2.1 Test: Combination Virtual Circuit Test | 43 |
| 4.2.2 Test 2: Combination Hardware Test | 46 |
| V CONCLUSION | 48 |
| 5.1 DISCUSSION | 48 |
| 5.2 RECOMMENDATION | 49 |
| 5.3 CONCLUSION | 49 |
| REFERENCE | 50 |
| APPENDICES | 51 |

LIST OF TABLES

| NO | TITLE | PAGE |
|-----------|--|-------------|
| 2.1 | VALUES AT THE INPUT PORT PINS | 12 |
| 2.2 | TRUTH TABLE FOR THE SEVEN-SEGMENT DISPLAY | 16 |
| 2.3 | PIC16F877A PINOUT DESCRIPTION | 21 |
| 4.1 | RESULT FOR THE TEST | 46 |

LIST OF FIGURE

| NO | TITLE | PAGE |
|-----|---|------|
| 1.1 | SUDOKU 9 X 9 MATRIX DISPLAY | 2 |
| 2 | 2A: ROW, COLUMNS AND BOXES | 7 |
| | 2B: FIGURE 1B: SUDOKU GUIDE | 8 |
| | 2C: EXAMPLE FOR SUDOKU | 9 |
| 2.1 | KEYPAD 4 X 4 | 10 |
| 2.2 | 7 SEGMENT DISPLAY | 15 |
| 2.3 | COMMON ANODE INTERNAL WIRING | 16 |
| 2.4 | ALPHANUMERIC LCD | 18 |
| 2.5 | PIC 16F877 PIN CONFIGURATION | 20 |
| 2.6 | PIC16F877A BLOCK DIAGRAM | 22 |
| 3.1 | VOLTAGE SUPPLY CIRCUIT FOR PIC16F877A | 27 |
| 3.2 | BASIC CIRCUIT FOR PIC16F877A | 27 |
| 3.3 | SOURCEBOOST ARCHITECTURE | 35 |
| 3.4 | COMMUNICATION BETWEEN USER AND PIC16F877A | 42 |
| 4.1 | DISPLAY UNIT CIRCUIT | 45 |
| 4.2 | THE WHOLE CIRCUIT -DISPLAY USING LCD DISPLAY | 47 |
| 4.3 | THE WHOLE CIRCUIT -DISPLAY USING 7-SEGMENT DISPLAY | 47 |

NOMENCLATURES

| | | |
|--------|---|--|
| PDA | - | Personal Digital Assistant |
| PRNG | - | Pseudo Random Number Generator |
| PIC | - | Peripheral Interface Controller |
| RAM | - | Random Access Memory |
| EEPROM | - | Electrically Erasable Programmable Read-Only Memory |
| A/D | - | Analog To Digital |
| DP | - | Decimal Point |
| LCD | - | Liquid Crystal Display |
| LED | - | Light-Emitting Diodes |
| IC | - | Integrated Circuit |
| VCC | - | Common-Collector Voltage |
| GND | - | Ground |
| DC- DC | - | Digital Current to Digital Current |
| AC-DC | - | Alternating Current to Digital Current |

LIST OF APPENDIX

| NO | TITLE | PAGE |
|-----------|--|-------------|
| A | THE 7SEGMENT DISPLAY DIMENSION | 52 |
| B | SCAN KEYPAD FOR 16 KEYS | 53 |
| C | SAMPLE COMMAND LINES | 54 |
| D | SOURCEBOOST IDE SIMULATOR FEATURES | 55 |
| E | EXAMPLE OF INSTRUCTION AND THE DESCRIPTION OF USING THE INSTRUCTION | 58 |
| F | PIC SUDOKU SOURCE CODE | 61 |

CHAPTER 1

INTRODUCTION

1.1 Overview

The objective of the project is summarized in figure 1.1 that is to design a simple circuit that can display number on 7-segment display or LCD display using a keypad with PIC16F877 as interface. The display should be arranged in a 9x9 matrix as required by Sudoku

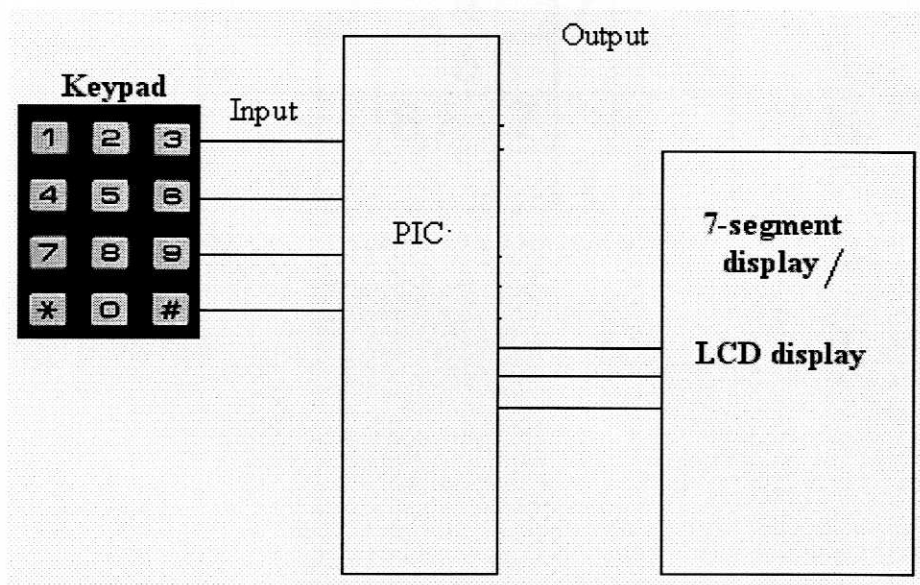

FIGURE 1.1: THE BLOCK DIAGRAM OF SUDOKU UNIT

In order to complete this display unit, I need to learn about PIC16F877A , the keypad and how the keypad communicate with PIC 16F877 and 7segment-display. In building this Sudoku Unit, three important components are required which are PIC 16F877, Keypad and 7-Segment Display or LCD display. At the end of the project a simple display unit is made available for playing sudoku

1.2 Objective

The main objective for this project is to be able to build a simple Sudoku unit by using 4 x 4 keypad, PIC16f877A and 9 x 9 7-segment displays

1.3 Scope Of Work

| | | | | | | | | |
|---|---|---|---|---|---|---|---|---|
| | 6 | 4 | | | | 1 | 2 | |
| | | | 4 | | 9 | | | |
| 7 | 9 | | | 1 | | | 3 | 4 |
| 4 | | 1 | | 9 | | 3 | | 8 |
| 9 | | | | 7 | | | | 2 |
| 8 | | 3 | | 4 | | 7 | | 5 |
| 2 | 1 | | | 6 | | | 7 | 3 |
| | | | 8 | | 7 | | | |
| | 4 | 7 | | | | 9 | 8 | |

FIGURE 1.1: SUDOKU 9 X 9 MATRIX DISPLAY

The scope of this project are;

- 1 to design a 9 x 9 matrix display using 7 Segment Display and LCD display,
- 2 to understand the working of the keypad and use it as an input to displaying numbers on the 7-segment or LCD display.
- 3 to be able to move the cursor over the 7segment matrix/LCD display and register numbers 1 – 9 as required in a Sudoku games.
- 4 to use a PIC to interface the keypad to the 7segment display/LCD display.
- 5 to understand the programming of PIC16F877A using SOURCEBOOST and simulate the circuit using PROTEUS
- 6 to construct the circuit using actual hardware
- 7 to use the design unit as a sudoku unit.

CHAPTER 2

LITERATURE REVIEW

2.1 History Of Sudoku Unit

Sudoku is a puzzle in which a grid consisting of several regions is to be filled with numbers so that every row, column, and region contains only one instance of each number. The most common format is a grid of nine rows and columns that are divided into nine smaller regions of three rows and three columns into which the numbers 1 through 9 must be placed.

The first puzzle was created by Howard Garnes, a freelance puzzle constructor, in 1979, and was first published in New York by the specialist puzzle publisher Dell Magazines in its magazine Dell Pencil Puzzles and Word Games, under the title Number Place.

This puzzle was subsequently introduced in Japan by Nikoli in the paper Monthly Nikolist in April 1984 as "Sūji wa dokushin ni kagiru", which can be translated as "the numbers must be single" or "the numbers must occur only once". The puzzle was named by Kaji Maki - the president of Nikoli. At a later date, the name was abbreviated to Sudoku (pronounced sue-do-koo; sū = number, doku = single); it is a common practice in Japanese to take only the first kanji of compound words to form a shorter version. In 1986, Nikoli made some changes to the Sudoku rules and introduced two innovations to the Sudoku Puzzle and gain popularity rapidly in

Japan. The number of givens was restricted to no more than 30 and puzzles became "symmetrical" (meaning the givens were distributed in rotationally symmetric cells). It is now published in mainstream Japanese periodicals, such as the Asahi Shimbun. Within Japan, Nikoli still holds the trademark for the name Sudoku; other publications in Japan use alternative names.

In 1989, Loadstar/Softdisk Publishing published DigitHunt on the Commodore 64, which was apparently the first home computer version of Sudoku. At least one publisher still uses that title.

Professor Yoshimitsu Kanai published his computerized version of Sudoku Puzzle generator under the name "Single Number" (the English translation of Sudoku) for the Apple Macintosh in 1995 in Japanese and English, and for the Palm (PDA) in 1996.

Kappa reprints Nikoli Sudoku in GAMES Magazine under the name Squared Away; the New York Post, USA Today, and San Francisco Chronicle now also publish the Sudoku Puzzle. It is also often included in puzzle anthologies, such as The Giant 1001 Puzzle Book (under the title Nine Numbers).

Bringing the process full-circle, Dell Magazines, which originally published the "Number Place" puzzle in United States, now publishes two Sudoku magazines: Original Sudoku and Extreme Sudoku.

A significant milestone for the development of Sudoku Puzzle traced to Wayne Gould, a New Zealander and a retired Hong Kong judge. In 1997, Gould was enticed by seeing a partly completed puzzle in a Japanese bookshop. He went on to develop a computer program that spontaneously produces Sudoku Puzzles; which took him over six years to complete, now marketed by Pappocom – Gould's software house. Knowing that British newspapers have a long history of publishing crosswords and other puzzles, he promoted Sudoku Puzzle to The Times in Britain, which launched it on 12 November 2004. The Sudoku Puzzles by Gould's Pappocom have been printed daily in the Times ever since.

It was in the year 2005 Sudoku Puzzle gains its International fame and popularity through the front page treatment by UK newspaper - The Daily Telegraph. Since then, it was rapidly introduced by several other national British newspapers including The Independent, The Daily Mail, The Guardian, The Sun (where it was labeled Sun Doku), The Daily Mirror; and subsequently other international papers. The immense surge in popularity of Sudoku in British newspapers and internationally has led to it being dubbed in the world media in 2005 variously as "the Rubik's cube of the 21st century" or the "fastest growing puzzle in the world".

2.2 Basic Sudoku Concept

Sudoku puzzles are based on a grid of 81 squares, which are arranged in 9x9 formats containing a selection of digits and blanks. The idea is to fill in the grid so that every row, every column, and every 3x3 box contains the digits 1 through 9.

In designing a Sudoku Puzzle generator, first complete set of 81 digits must be created in which these simple logic rules apply. Then blanks are added to hide a selection of those digits. The rest is down to the player to decide which digits the blanks represent. In the unit presented here, a pseudo random number generator (PRNG) is used to generate the first nine digits which comprise an initial 3x3 square. Permutations of those digits are then copied to the other squares, abiding by the basic rules of no repetition of digits in the rows, columns or the 3x3 sub-squares. PIC microcontroller is used to program the number into the 9x9 display. The keypad is a low-cost 4x4 matrix device. Which key is pressed is decoded via PIC. Key 1 to 9 is the digits needed by the puzzle.

The basis of sudoku is a nine-by-nine grid. There are three sections to think about: rows, columns and boxes.

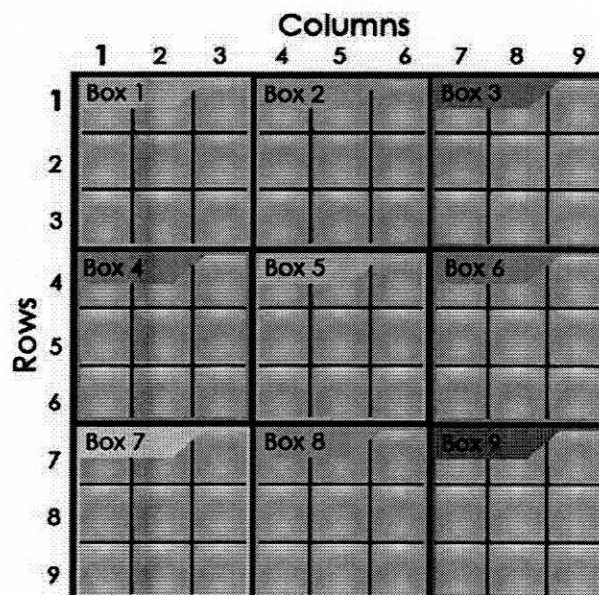

FIGURE 2A: ROW, COLUMNS AND BOXES

The goal of sudoku is to fill each nine-square row, each nine-square column and each nine-square box with the numbers 1 through 9, with each number used once

and only once in each section. It is the interaction between the rows, columns and boxes that tells you where the numbers need to go. So if the player starting with a blank grid and fill in the numbers for row 1, column 2 and box 4 according to the sudoku rules, it might look something like figure 2B. Row 1 has one and only one of each digit, as do column 2 and box 4, even though those sections overlap

| 1 | 2 | 3 | 4 | 5 | 6 | 7 | 8 | 9 |
|---|---|---|---|---|---|---|---|---|
| | 3 | | | | | | | |
| | 7 | | | | | | | |
| 2 | 4 | 8 | | | | | | |
| 3 | 5 | 1 | | | | | | |
| 7 | 6 | 9 | | | | | | |
| | 1 | | | | | | | |
| | 8 | | | | | | | |
| | 9 | | | | | | | |

FIGURE 1B: SUDOKU GUIDE

Starting with a blank grid would not make it much of a challenge. A sudoku puzzle already has some of the numbers filled in, and it is the player's job to figure out where the rest of the numbers go. Figure 2C shows the example of Sudoku Games. A sudoku puzzle has some "clues" filled in.

| | | | | | | | |
|---|---|---|---|---|---|---|---|
| 9 | | | 8 | 2 | | | 6 |
| | | | 9 | 3 | | | |
| 3 | | 7 | | | 4 | | 8 |
| | | 2 | 5 | | 7 | 8 | |
| | 4 | | | | | | 3 |
| | | 6 | 1 | | 4 | 2 | |
| 2 | | 8 | | | | 1 | 3 |
| | | | 3 | | 9 | | |
| 6 | | | 4 | | 8 | | 2 |

FIGURE 1C: EXAMPLE FOR SUDOKU

Sudoku has several levels of difficulty, from easy to very hard, based on how many numbers you get to start with and where those numbers are positioned. An easy puzzle gives you enough numbers placed in enough strategic positions to allow you to find the answer using fairly simple logic. Each puzzle has only one answer. The best way to learn the art of Sudoku is by working through a puzzle.