

STUDY ON THE PERFORMANCE OF CARBON ADSORBENT IN LPG TANK
FOR SMALL ENGINE FUELLED BY LPG.

ISMANIZA BINTI ISMAIL

UNIVERSITI TEKNIKAL MALAYSIA MELAKA

STUDY ON THE PERFORMANCE OF CARBON ADSORBENT IN LPG TANK
FOR SMALL ENGINE FUELLED BY LPG

ISMANIZA BINTI ISMAIL

This report is written as a partial fulfillment of terms in achieving the award for
Bachelor of Mechanical Engineering (Thermal-Fluid)

Faculty of Mechanical Engineering
Universiti Teknikal Malaysia Melaka

MAC 2008

‘I/We approve that we have read this thesis thoroughly and in my/ our opinion, this thesis is has fulfilled the criteria covering all the aspects of scope and quality and satisfied to be awarded for Bachelor of Mechanical Engineering (Thermal-Fluid).’

Signature :.....
Supervisor I :.....
Date :.....

Signature :.....
Supervisor II :.....
Date :.....

“I admit that this report is all written by myself except for the summary and the article which I have stated the source for each of them.”

Signature :.....
Writer :.....
Date :.....

TO MY BELOVED MOM AND DAD...

TO ALL MY BEST FRIENDS...

ACKNOWLEDGEMENT

In this great opportunity, I would like to thank Allah for providing me strengths to finish up this project and finally it was completed. Here, I would like to acknowledge with appreciation to all those people who helped me numerously during finish up my project for this year.

In a particular, I would like to express my gratitude to my supervisor, Mr Safarudin Gazali Herawan for giving me a chance to do the project under his guide and attention. I also would like to forward my thanks to Mr Asjufri for giving me lots of guides and advices during implementation of this project. I would also forward my thanks to my second supervisor, Mr Zakaria Nasir who gave me advices and supports too. And not to forget to all panels that evaluated my presentation, a very big thanks to all of you.

Finally, I would like to express my appreciation to everyone especially to all my friends who helped me lots and supported me either. Thanks for your guidance and cooperation. May Allah bless all of you. Amin..

ABSTRAK

Cecair petroleum gas (LPG) digunakan untuk peralatan pemanasan dan juga untuk kenderaan. Pada masa kini, penggunaan LPG sebagai bahan api alternatif untuk kenderaan adalah meluas. Akan tetapi, terdapat beberapa masalah yang timbul apabila menggunakan LPG pada kenderaan. Oleh itu, penyerap carbon digunakan di dalam tangki LPG untuk menambah muatannya. Di dalam projek ini, laporan memfokuskan tentang pembangunan dan persediaan penyerap carbon dengan menggunakan kaedah yang baru dan dibandingkan dengan kaedah yang sebelumnya. Kaedah yang baru tidak menggunakan sebarang gas dalam pembakaran kerana kosnya yang mahal. Oleh itu hasil keputusan daripada kaedah yang baru akan menentukan samada prestasi penyerap carbon adalah lebih efisien atau tidak serta menjimatkan apabila diaplikasikan dalam tangki LPG. Malangnya, keputusan yang diperolehi menunjukkan kaedah yang lama lebih baik dalam penghasilan penyerap karbon berbanding kaedah yang baru. Oleh yang demikian, kaedah yang lebih baik perlu digunakan untuk menghasilkan penyerap karbon yang baik dan cara penyediaanya ringkas lagi menjimatkan.

ABSTRACT

Liquefied Petroleum Gas (LPG) is used as a fuel in heating appliances and vehicles as well. Nowadays, the use of LPG as an alternative fuels for vehicles are widely. But somehow, there are several problems arised when applying the LPG for vehicles. So, in order to overcome such problems, the carbon adsorbent is being used in LPG tank for increasing the storage capacity. In this project, the report is more focuses on development and preparation of carbon adsorbent by using the new method compare to the current method by the current research. The result will determine the performance of carbon adsorbent in LPG tank of which method is more efficient and more saving when applied to LPG tank. The new method is not using any gas in the process as it is costly. Therefore, the performance of carbon adsorbent can be obtained after the results. Unfortunately, results had shown that the current method performed better in producing carbon adsorbent compared to the new one. For the recommendation, it is suggested that a better, simple and more saving method have to be applied.

TABLE OF CONTENT

CHAPTER	TITLE	PAGES
	DECLARATION	ii
	DEDICATION	iii
	ACKNOWLEDGEMENT	iv
	ABSTRAK	v
	ABSTRACT	vi
	CONTENT	vii
	LIST OF TABLE	x
	LIST OF FIGURE	xi
	LIST OF APPENDICES	xv
CHAPTER 1	INTRODUCTION	
	1.1 Background Research	1
	1.2 PSM Gantt Chart	3
	1.3 Problem Analysis	4
	1.4 Scope and Objective	5
CHAPTER 2	LITERATURE REVIEW	
	2.1 Activated Carbon	6
	2.2 Source Material	7
	2.3 Production	7
	2.4 Classifications	9

	3.5.3 Preparation of carbon adsorbent using the Compression method	32
	3.5.4 Preparation of testing the performance of Carbon adsorbent in LPG tank	35
3.6	Problem analysis and solution	36
CHAPTER 4	RESULTS AND DATA ANALYSIS	
4.1	Experiment 1: Conventional Method	37
4.2	Experiment 2: Compression Method	38
4.3	Experiment 3: Testing Performance	40
CHAPTER 5	DISCUSSION	44
CHAPTER 6	CONCLUSION AND SUGGESTIONS	46
	REFERENCES	49
	APPENDICES	52

LIST OF TABLES

NO.	TITLES	PAGES
2.1	The properties of LPG	17
4.1	Weight of samples at 700°C after pyrolysis process	37
4.2	Weight and force of sample at different temperature	38
4.3	Weight of gas adsorbed for various sample due to different temperature	42

LIST OF FIGURES

NO.	TITLES	PAGES
1.1	PSM Gantt chart.	3
2.1	Activated carbon	6
2.2	Close up of sample activated carbon	6
2.3	Carbonized coconut	8
2.4	Activated coconut	8
2.5	Production activated carbon chart	8
2.6	PAC	9
2.7	GAC	10
2.8	Close up of carbon surface and pores magnification increases from left to right	12
2.9	LPG cylinder tank	15
3.1	Methodology chart	20
3.2	Current design for conventional method	22
3.3	New design for compression method	23

3.4	Concept design of top part	23
3.5	Concept design of reactor	24
3.6	Design for reaction body part 1 in 2D view	25
3.7	Design for reaction body part 2 in 2D view	25
3.8	Design of top part in 2D view	26
3.9	Design of plate sieve in 2D view	26
3.10	Sieve is located below the top part surface	27
3.11	Sieve is located inside the reactor	27
3.12	Sieve of size 250 – 425 μm	28
3.13	Sample of granular	28
3.14	Sample of particles	29
3.15	Sample of powder	29
3.16	Current design of reactor	30
3.17	Suction blower	30

3.18	Nitrogen and carbon dioxide gas tank	30
3.19	Control meter of gas flow rate	31
3.20	Process using compression method	32
3.21	Sample is being weighed	32
3.22	New design of reactor	33
3.23	Hydraulic jack	33
3.24	Top plate	33
3.25	Process using compression method	34
3.26	Top view of the process by using compression method	34
3.27	Location of force gauge	35
3.28	Cylindrical test bed on the digital balance	36
3.29	LPG's tank that used in adsorption test	36
4.1	Graph of weight changes for samples using conventional method	38
4.2(a)	Graph of force against temperature in compression method	39

4.2(b)	Graph of weight against temperature in compression method	40
4.2(c)	Graph of weight changes at different temperature in compression method	41
4.3(a)	Graph of weight for gas adsorbed against different temperature	43
4.3(b)	Graph of weight change for all samples	44
5.1	Flaming occurred at temperature 500°C by using compression method	46

LIST OF APPENDICES

NO.	TITLE	PAGES
A	LPG	53
B	Process for producing activated carbon (U.S. Patent)	55

CHAPTER 1

INTRODUCTION

Carbon adsorbent is also known as activated carbon. The active carbon is a material with an exceptionally high surface area. One gram of activated carbon has a surface area of approximately 500 m², typically determined by nitrogen gas adsorption, and includes a large amount of microporosity.

The active carbon can be produced in different process from a variety of carbonaceous source materials such as coconut shells, coal, walnut shell, palm date pits, nutshell and oil palm shell. The two different processes include physical reactivation and chemical activation.

Normally, the activated carbon is used in gas purification, metal extraction, water purification, medicine, sewage treatment, air filters in gas masks and filter masks, filters in compressed air and many other applications.

1.1 Background research

In order to reduce air pollution, many countries had used LPG as an alternative way replacing natural gas and petrol as a fuel in their vehicles. The use of LPG is more economic because it is simply to prepare and easy to use as the LPG is not using the high pressure tank compared to natural gas.

Many researches are being done to improve the use of LPG in the automotive industry. One of the current researches is to develop LPG and methane gas storage as the alternative fuels for vehicles based upon the carbon adsorbent. Carbon adsorbent or active carbon is used as a gas storage media for LPG is an alternative way to overcome the disadvantages of pressurized vessel such as high pressure flammable gas content, dimension of gas tank and other dangerous aspects.

The current research of using the carbon adsorbent in LPG is successfully worked as the carbon adsorbent has a potential to adsorb the gas based on its characteristics. For this project, the objective is to develop and prepare a carbon adsorbent that can be used in LPG tank for increasing the storage capacity. In terms of that, different techniques and preparation procedures are being used to investigate the effects on the pore structures development on carbon because it is important in gas adsorption and desorption processes.

1.2 PSM flow chart

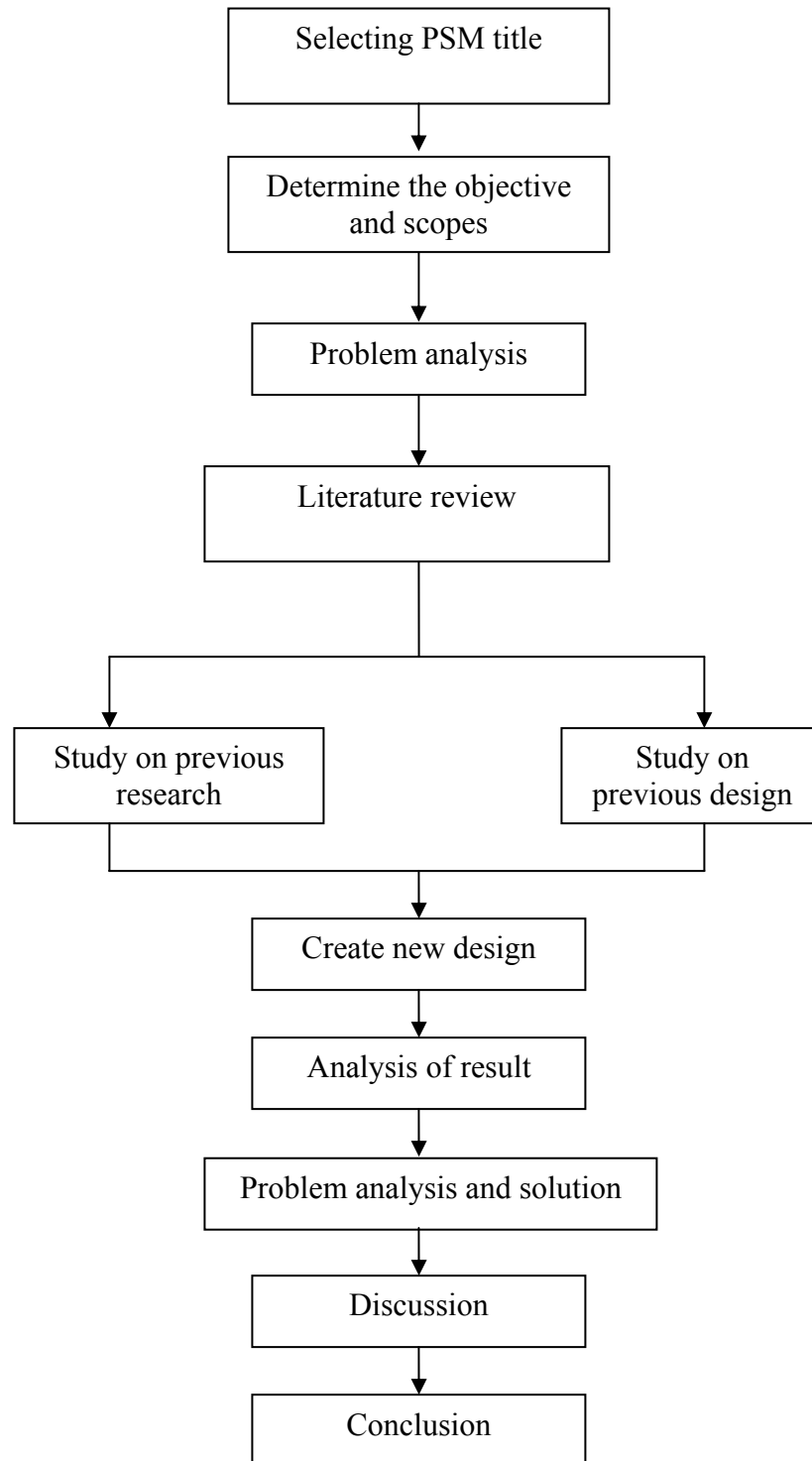

Figure 1.1 PSM flow chart

1.3 Problem Analysis

Liquefied petroleum gas (LPG) is used to replace the petrol because of the fuel cost is rapidly increase nowadays. Using LPG as a fuel for vehicles give more advantages than the others fuel. This is because the LPG is more economic and is not using high pressure tank.

In application for the vehicles, a small tank for LPG storage with high capacity is needed. In order to increase the storage capacity in small LPG tank, carbon adsorbent is used. Carbon adsorbent has a potential to adsorb LPG due to its characteristics. Carbon adsorbent was prepared by the process of carbonization and activation on previous research.

Even the process is capable to produce carbon adsorbent in high adsorption capacity; the process is occurs in high temperature and using N_2 and CO_2 gas. Heating at high temperature take a long time to get the product and the use of N_2 and CO_2 gas have to be control to obtain the specific flow rate and CO_2 is costly.

1.4 Scope

Objective

- To develop and prepare a carbon adsorbent that can be used in LPG tank for increasing the storage capacity.

Scopes

- Design and develop an experimental rig for preparing carbon adsorbent
- Design and develop an experimental rig for testing carbon adsorbent in LPG tank
- Determine the performance of a carbon adsorbent in LPG tank

CHAPTER 2

LITERATURE REVIEW

2.1 Activated carbon

Carbon adsorbent is also known as activated carbon. The activated carbon is a material with an exceptionally high surface area. One gram of activated carbon has a surface area of approximately 500 m^2 , typically determined by nitrogen gas adsorption, and includes a large amount of microporosity.

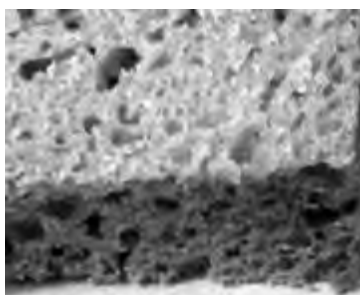

Figure 2.1 Activated carbon



Figure 2.2 Close up of sample activated carbon

(Source: www.wikipedia.com)

2.2 Source material

The activated carbon can be produced in different process from a variety of carbonaceous source materials. The potential natural precursors for carbon adsorbents include coconut shells, coal, walnut shell, palm date pits, nutshell and oil palm shell.

2.3 Production

There are two different processes in producing the activated carbon. It can be produced using one of the two following processes:

1. **Physical reactivation:** The precursor is developed into activated carbons using gases. This is generally done by using one or combining the following processes:
 - Carbonization: material with carbon content is pyrolysed at temperatures in the range 600-900°C, in absence of air (usually in inert atmosphere with gases like nitrogen)
 - Activation/oxidation: raw material or carbonized material is exposed to oxidizing atmospheres (carbon dioxide, oxygen, or steam) at temperature above 250°C, usually in the temperature range 600-1200°C.
2. **Chemical activation:** Impregnation with chemicals such as acids like phosphoric acid or bases like potassium hydroxide, sodium hydroxide or salts like zinc chloride, followed by carbonization at temperatures in the range 450-900°C. It is believed that the carbonization / activation step proceeds simultaneously with the chemical activation. This technique can be problematic in some cases because, for example, zinc trace residues may remain in the end product. However, chemical activation is preferred over physical activation owing to the lower temperatures and shorter time needed for activating material.

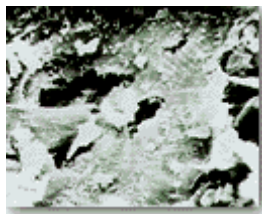

Figure 2.3 Carbonized coconut

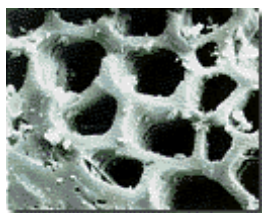

Figure 2.4 Activated coconut

(source:www.wikipedia.com)

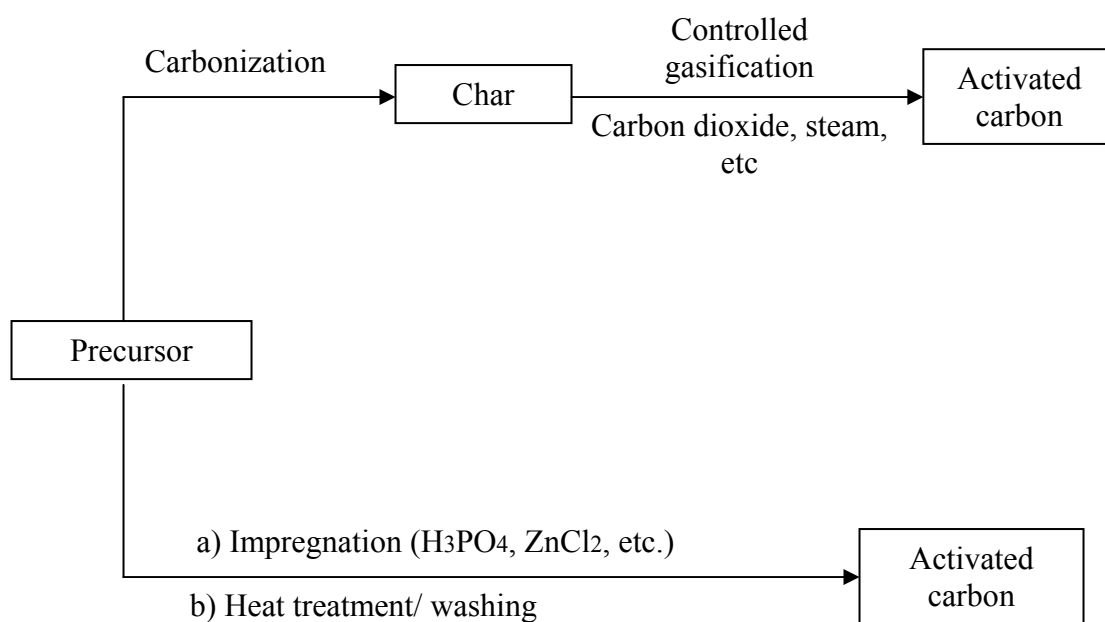

Figure 2.5 Production activated carbon chart

2.4 Classifications

Activated carbons are complex products which are difficult to classify on the basis of their behavior, surface characteristics and preparation methods. However, some broad classification is made for general purpose based on their physical characteristics.

2.4.1 Powdered activated carbon (PAC)

PAC is made up of crushed or ground carbon particles, 95-100% of which will pass through a designated mesh sieve or sieve. The size of this form is less than 1.0mm with average diameter 0.15 and 0.25mm thus they present a large internal surface with a small diffusion distance. Commonly, the PAC is not used in a dedicated vessel, owing to the high head loss that would occur. PAC is generally added directly to other process units, such as raw water intakes clarifiers and gravity filters.

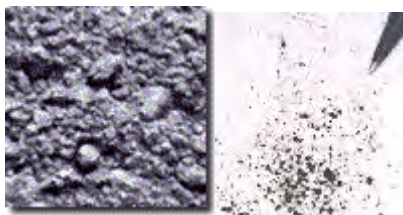

Figure 2.6 PAC

(source: www.wikipedia.com)

2.4.2 Granulated activated carbon (GAC)

This form of activated carbon has a relatively larger particle size than the powdered activated carbon. These carbons are preferred for all adsorption of gases and vapors as their rate of diffusion are faster and presents a smaller external surface. GAC are used for water treatment, deodorization and separation of components of flow system.

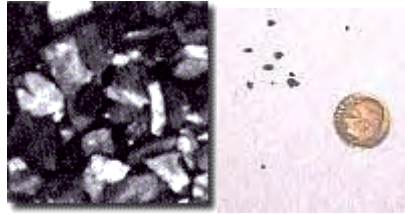

Figure 2.7 GAC

(source: www.wikipedia.com)

2.4.3 Pelleted activated carbon

It consists of extruded and cylindrical shaped activated carbon with diameters from 0.8 to 5mm. Factors that it is mainly used for gas applications are of their low pressure drop, high mechanical strength and low dust content.

2.4.4 Impregnated carbon

Porous carbon containing several types of inorganic impregnate such as iodine, silver, cation such as Al, Mn, Zn, Fe, Li, Ca have also been prepared for specific application in air pollution control especially in museums and galleries. Silver loaded activated carbon is used as an adsorbent for purifications of domestic water. Impregnated carbons are also used for the adsorption of H_2S and mercaptans.

2.4.5 Polymers coated carbon

Polymers coated carbon is a porous carbon that is coated with biocompatible polymer to give a smooth and permeable coat without blocking the pores. This carbon is useful for hemoperfusion treatment technique in which large volumes of the patient's blood are passed over an adsorbent substance in order to remove toxic substances from the blood.

2.5 Characteristic of activated carbon

The main important characteristic of carbon adsorbent is its high porosity. Generally, its physical characterization is more important than chemical characterization. The microporous structure of the carbon adsorbent can be characterized by standardized techniques. The most important physical characteristics include pore volume, pore size distribution, and surface area.

The surface area of a sorbent can be determined by BET method. Adsorption data for nitrogen at the liquid N₂ temperature, 77K are usually used in the method. The Brunaur-Emmett-Teller (BET) equation is used to calculate the amount of N₂ for monolayer coverage.

In characterizing the pore volume, both total pore volume and its distribution over the pore diameter are needed. The total pore volume is usually determined by helium and mercury densities or displacements. Helium is used because of its small atomic size and negligible adsorption gives the total voids whereas mercury does not penetrate into the pores at ambient pressure and gives interparticle voids.

2.6 Surface properties for adsorption

The unique surface property of activated carbon is that its surface is nonpolar or only slightly polar as a result of surface oxide groups and inorganic impurities. This unique property gives activated carbon the following advantages:

1. It is the only commercial sorbent used to perform separation and purification processes without requiring prior stringent moisture removal such as is needed in air purification. (It is also useful in aqueous process).
2. Because of its large accessible internal surface, it adsorbs more nonpolar and weakly polar organic molecules than other sorbents do. For example, the amount of methane adsorbed by activated carbon at 1 atmosphere (atm) and room temperature is approximately twice that adsorbed by an equal weight of molecular sieve 5A.

3. The heat of adsorption or bond strength is generally lower on activated carbon than on other sorbents. Consequently, stripping of the adsorbed molecules is easier and results in lower energy requirements for regeneration of the sorbent.

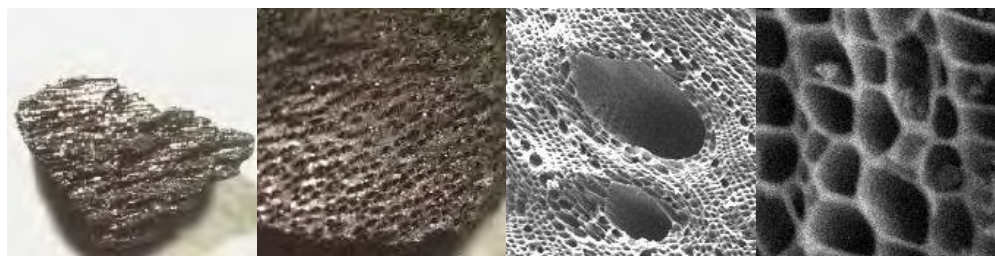

Figure 2.8 Close up of carbon surface and pores magnification increases left to right
(source: www.wikipedia.com)

2.7 Description of Production process

Active carbon is mainly exclusively prepared by the pyrolysis of carbonaceous raw material at temperature lower than 1000°C. The preparation involves two main steps: carbonization of the raw material at temperatures below 800°C in an inert atmosphere, and activation of the carbonized product between 950 and 1000°C. All carbonaceous materials can be converted into active carbon although the properties of the final product will be different, depending upon the nature of the raw material used, the nature of the activating agent and the conditions of activation process.

During carbonization most of the noncarbon elements such as oxygen, hydrogen, nitrogen and sulfur are eliminated as volatile gaseous products by the pyrolytic decomposition of the source raw material. The residual elementary carbon atoms group themselves into stacks of aromatic sheets cross-linked in a random manner. The mutual arrangement of these aromatic sheets is irregular and therefore leaves free interstices between the sheets which may become filled with the tarry matter or the products of decomposition or at least blocked partially by disorganized carbon. These interstices give rise to pores that make active carbons excellent adsorbents.

The char produced after carbonization does not have a high adsorption capacity because of its less developed pore structure. This pore structure is further enhanced during the activation process when the spaces between the aromatic sheets are cleared of various carbonaceous compounds and disorganized carbon. The activation process converts the carbonized char into a form that contains the largest possible number of randomly distributed pores of various shapes and sizes, giving rise to a product with an extended and extremely high surface area.

2.8 Adsorption process

Due to the unsaturated and unbalanced forces, the solid of carbon has tendency to attract and retain on its surface molecules and ions of other substances with which it comes into contact. Thus, when the solid surface comes in contact with a gas or a liquid, the concentration of the gas or liquid is always greater on the surface of the solid than in the bulk gas or liquid phase. The process by which this surface excess is created is called adsorption. The balance of the forces is partially restored by the adsorption of the gas or the liquid on the surface of the to which it is attached is known as the adsorbent. The adsorption capacity is determined mainly by the dispersion component of the van der Waals forces.

Depending upon the nature of the forces involved, the adsorption is of two types: physical or van der Waals adsorption, and chemisorption or chemical adsorption. In the case of physical adsorption, the adsorbate is bound to the surface by relatively weak van der Waals forces identical with molecular forces of cohesion that are involved in the condensation of vapors into liquids. Chemisorption, on the other hand, involves exchange or sharing of electrons between the adsorbate molecules and the surface of the adsorbent, resulting in a chemical reaction. The bond formed between the adsorbate is essentially a chemical bond and is thus much stronger than physical adsorption. Other types of adsorption that takes place in a given adsorbate-adsorbent system depends on the nature of the adsorbate, the nature of the adsorbent, the reactivity of the surface, the surface area of the adsorbent and the temperature and pressure of adsorption.

Adsorption efficiency decreases over time and eventually activated carbon will need to be replaced or reactivated. Isotherms are empirical relations which are used to predict how much solute can be adsorbed by activated carbon. The most well known isotherms are the Freundlich, Langmuir, Frumkin and BET. Below is a purely empirical formula valid for gaseous adsorbates of the first isotherm due to the Freundlich and Küster (1894):

$$\frac{x}{m} = k \times P^n$$

Where,

x = adsorbed quantity

m = mass of adsorbent

P = pressure of adsorbate

k, n = empirical constants

2.9 Liquefied Petroleum Gas (LPG)

LPG or LP Gas is the abbreviation of Liquefied Petroleum Gas. This group of products includes saturated Hydrocarbons - Propane (C_3H_8) and Butane (C_4H_{10}), which can be stored or transported separately or as a mixture. They exist as gases at normal room temperature and atmospheric pressure.

It is called Liquefied Petroleum Gas because these gases liquefy under moderate pressure. They liquefy at moderate pressures, readily vaporizing upon release of pressure. It is this property that permits transportation of and storage of LP Gas in concentrated liquid form.

LPG comes from two sources. It can be obtained from the refining of crude oil. When produced this way it is generally in pressurized form. LPG is also extracted from natural gas or crude oil streams coming from underground reservoirs. 60% of LPG in the world today is produced this way whereas 40% of LPG is extracted from refining of crude oil.

Ideally products referred to as "propane" and "butane" consist very largely of these saturated hydrocarbons; but during the process of extraction/production certain allowable unsaturated hydrocarbons like ethylene, propylene, butylenes etc. may be included in the mixture along with pure propane and butane. The presence of these in moderate amounts would not affect LPG in terms of combustion but may affect other properties slightly (such as corrosiveness or gum formation).



Figure 2.9 LPG cylinder tank

The characteristics of LPG are as follows:

The characteristics of LPG are as follows:

- It is colorless and cannot be seen
- It is odorless. Hence LPG is odorized by adding an odorant prior to supply to the user, to aid the detection of any leaks.
- It is slightly heavier than air and hence if there is a leak it flows to lower lying areas.
- In liquid form, its density is half that of water and hence it floats initially before it is vaporized.
- It is non-toxic but can cause asphyxiation in very high concentrations in air.

LPG expands upon release and 1 liter of liquid will form approximately 250 liters of vapor.

LPG is used as a fuel for domestic (cooking), industrial, horticultural, agricultural, heating and drying processes. LPG can be used as an automotive fuel or as a propellant for aerosols, in addition to other specialist applications. LPG can also be used to provide lighting through the use of pressure lanterns.

The advantages of LPG are as follows

- Because of its relatively fewer components, it is easy to achieve the correct fuel to air mix ratio that allows the complete combustion of the product. This gives LPG its clean burning characteristics.
- Both Propane and Butane are easily liquefied and stored in pressure containers. These properties make the fuel highly portable, and hence, can be easily transported in cylinders or tanks to end-users.
- LPG is a good substitute for petrol in spark ignition engines. Its clean burning properties, in a properly tuned engine, give reduced exhaust emissions, extended lubricant and spark plug life.
- As a replacement for aerosol propellants and refrigerants, LPG provides alternatives to fluorocarbons, which are known to cause deterioration of the earth's ozone layer.

The clean burning properties and portability of LPG provide a substitute for traditional fuels such as wood, coal, and other organic matter. This provides a solution to de-forestation and the reduction of particulate matter in the atmosphere (haze), caused by burning the traditional fuels.

Table 2.1 The properties of LPG (Source: e-lpg.com)

Property	Units	Commercial Propane	Commercial Butane	Mixture 50% each
Specific gravity of Liquid at 15 deg C (Water=1)		0.504	0.582	0.543
Specific gravity of Vapor at 15 deg C (Air=1)		1.5	2.01	1.75
Vapor pressure at 38 deg C	Kg/sq.cm	13.8	2.6	8.0
Boiling point at atm pressure	Deg C	- 42	9	+ 9 to - 42
Ignition temperature in air	Deg C	495-605	480-535	480-605
Latent Heat of Vaporization	Btu/lb	184	167	175

2.10 Review from current research

The current research focuses on the experimental investigation of carbon adsorbent produced from oil shell as a raw material. These carbon materials can be used for catalyst supports and adsorbents because of its prominent characteristics such as high surface area, relatively uniform pore size, ordered pore structure and good thermal and mechanical stabilities.

The use of oil palm shell as a carbon feed stocks gives more advantages include high density, availability as renewable resources, low cost, low ash content and capable of producing activated carbon of high adsorption capacity.

Next, the research had been proceeded to develop a liquefied petroleum gas (LPG) and methane gas storage media for vehicles based upon the carbon adsorbents. The purpose of using the carbon adsorbent as a gas storage media for LPG methane gas are as an alternative way to overcome the disadvantages of pressurized vessel such as high pressure flammable gas content, dimension of gas tank and other dangerous aspects.

2.11 Preparation of carbon adsorbent in previous research

In order to prepare carbon adsorbent, the apparatus are consisted of a reactor, tube furnace, suction blower and some accessories.

First of all, the oil palm shells were crushed and sieved into a size of 250-450 μm separately. About 40g of each formed particles were fed in the reactor. The char was prepared at 10°C/min of the heating rate in between 300°C up to 800°C and was maintained for 60 minutes in 1.51 l/min of N_2 flow.

Next is to prepare activated carbon from the char products by using the carbonization and activation process. These process is carried out in a laboratory scale, single step fixed bed reactor which blanketed by tube furnace where the pyrolysis process take place. Nitrogen gas is used to obtain an inert atmosphere in the reactor and CO_2 gas is used to activate the sample. A suction blower is used to remove volatile

matter as well as other gases during the process. Optimization of the activated carbon can be achieved by varies peak temperature, heating rate and residential time of the sample. For application, a carbon adsorbent test bed is used to observe the adsorptive and desorptive capacity of hydrocarbon gas at carbon adsorbent.

Temperature for carbonization and activation process can affect the initial porosity development of char characterization results. Previous result indicates that more volatiles matters were released due to the weight changes and new microporosities have been developed at higher temperature. The higher activation temperature, the greater surface area of resultant activated carbon and this can increase the ability to adsorb more LPG gas.

CHAPTER 3

METHODOLOGY

3.0 Introduction

Methodology is defined as the analysis of the principles of methods, rules and postulates employed by a discipline. It is also defined as a particular procedure or set of procedures that refers to more than a simple set of methods. In this project, the methodology is includes of the following flow chart below:

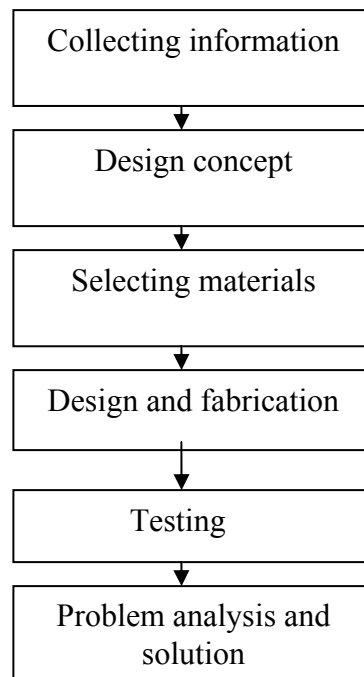

Figure 3.1 Methodology chart

3.1 Collecting information

All the information about the production and adsorption process of activated carbon has been searched from internet and books. The information is important to guide in designing the new method of producing the activated carbon.

3.2 Design

Design an experimental rig for preparing and testing carbon adsorbent in LPG tank for fabrication process and comparison on current method of production activated carbon thus to determine the performance of a carbon adsorbent are needed.

3.2.1 Design Concept

The current method of producing carbon adsorbent is done by using the carbonization and activation process. Material with carbon content is pyrolysed at high temperatures and use N_2 and CO_2 gas to obtain an inert atmosphere and activate it respectively. However, the process of heating material to high temperature take a long time as well as to cool it down to get the product. Meanwhile, the use of N_2 and CO_2 gas is costly.

In order to avoid the use of N_2 and CO_2 gas and heating on high temperature, the new method has been designed to compare with the current method. The new method is using a compression concept where it does not use any N_2 and CO_2 gas on high temperatures when pyrolysis process occurs.

Theoretically, whenever compression process is occurred it will subject to the high pressure. The high pressure will cause the temperature inside the reactor increase due to the Pressure's Law principle. Pressure's Law related to pressure versus temperature whereas it is proportional when the volume of gases are constant.

$$\frac{P_1}{T_1} = \frac{P_2}{T_2}$$

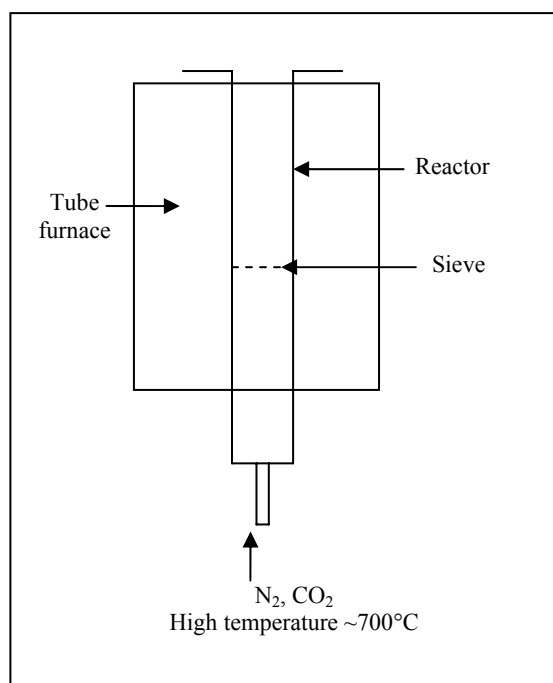
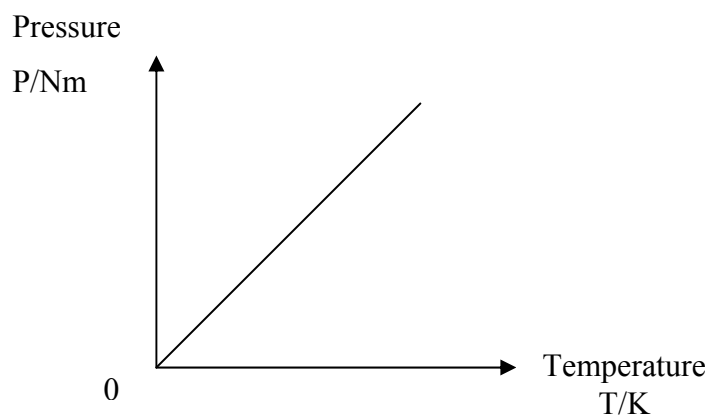

Figure 3.2 Current designs for conventional method

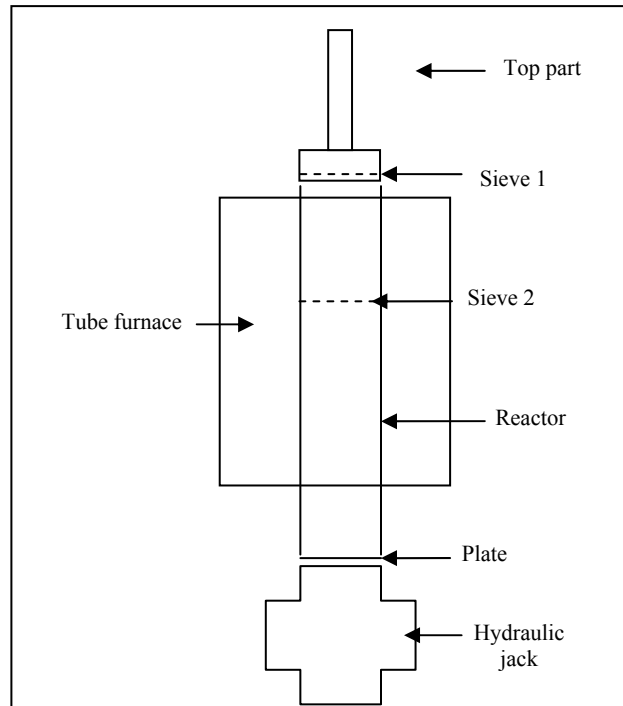

Figure 3.3 New designs for compression method

3.2.2 Part of design

Top part is designed as to allow the compression process. The parts of top include the top itself and the sieve 1. Arrow shown in figure 3.4 below is the part where sieve 1 covered with sieve plate located.

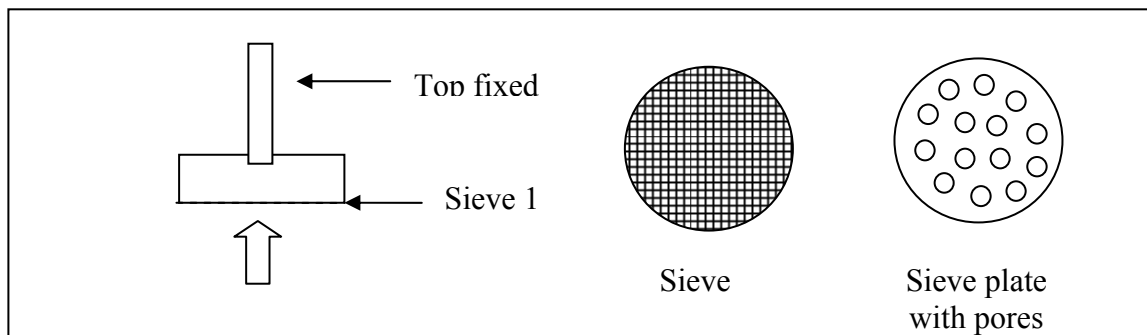

Figure 3.4 Concept design of top part

Reactor is the part where pyrolysis process occurs. This part includes of body of reactor, sieve 2 and plate at the end of reactor as shown in figure above. Plate at the end of reactor is designed to allow hydraulic jack to push up the reactor body as to make it compress and touch the top part.

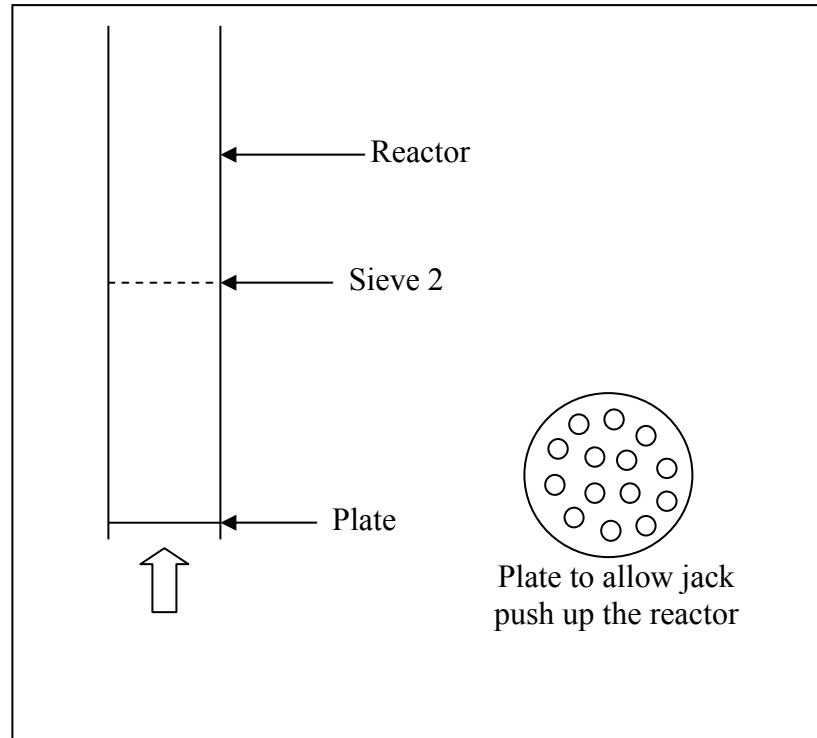

Figure 3.5 Concept design of reactor

3.3 Design and fabrication

Before fabrication process, the previous size of reactor and furnace tube has been measured as a reference to make a new design. Solid work software is used to design all the parts. All the designs for compression method are shown by figures below.

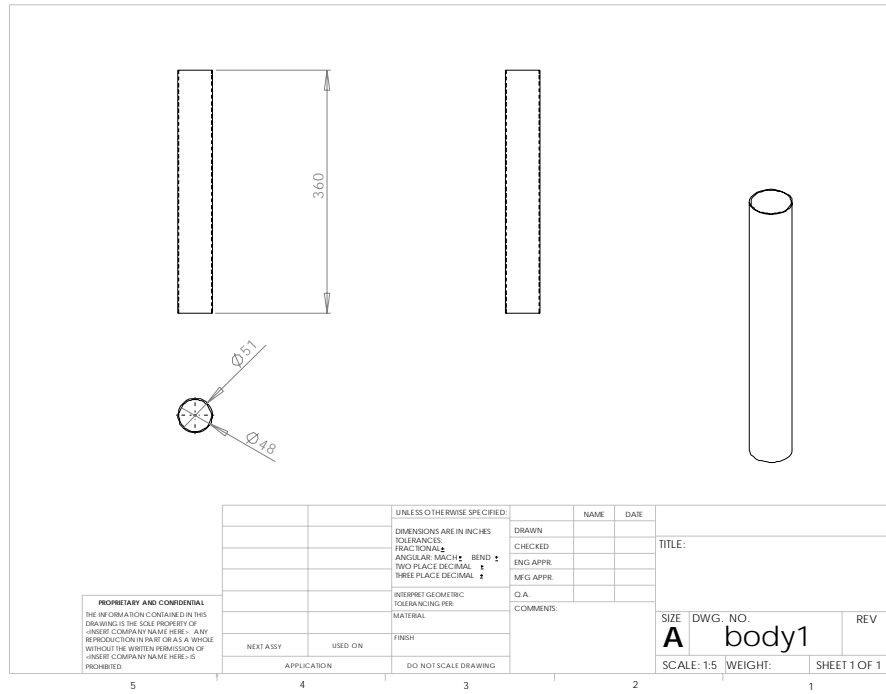

Figure 3.6 Design for reactor body part 1 in 2D view

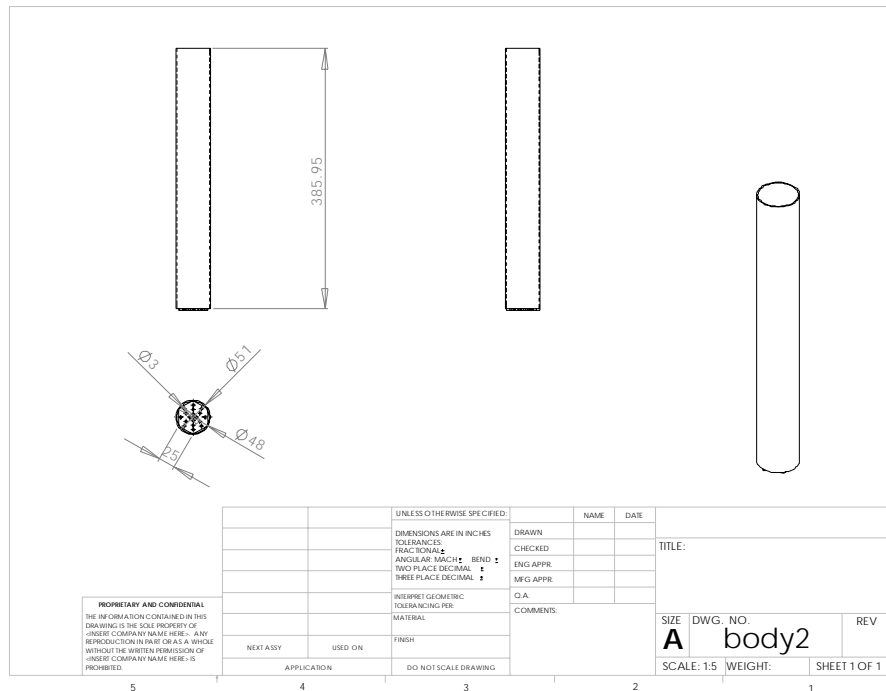

Figure 3.7 Design of reactor body part 2 in 2D view

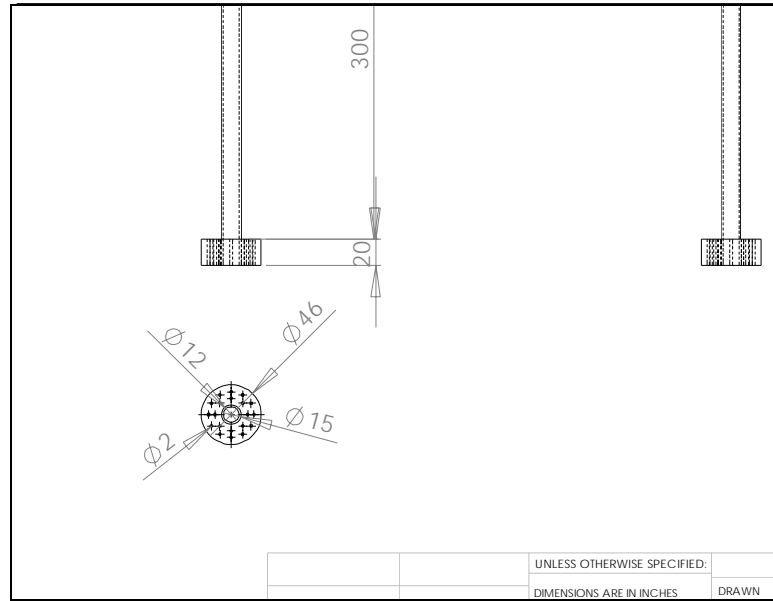

Figure 3.8 Design of top part in 2D view

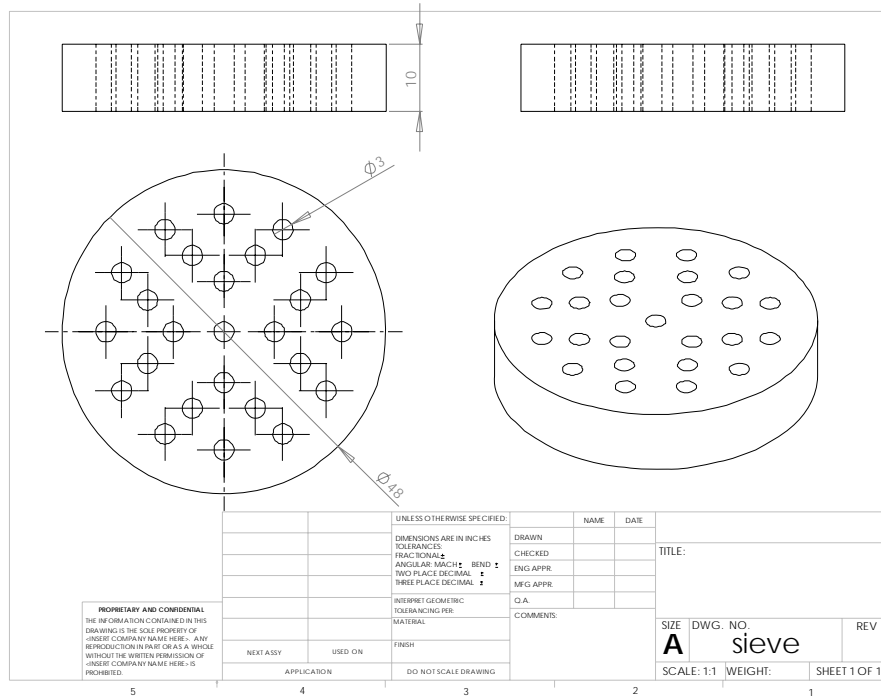

Figure 3.9 Design of plate sieve in 2D view



Figure 3.10 Sieve is located below top part surface

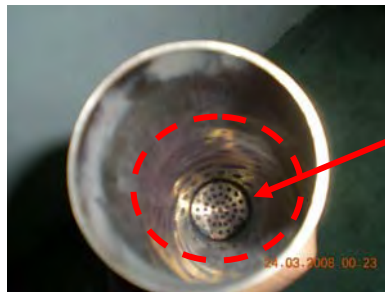

Figure 3.11 Sieve is located inside the reactor

3.4 Selecting material

Material from stainless steel is used for reactor and the sieve is also made from stainless steel. These types of material have been chosen because they have high thermal conductivity and are appropriate for processes involving high temperature.

3.5 Testing

The testing process was done and the results have been achieved. A comparison between the previous method and the present method can be obtained. All the preparations to produce carbon adsorbent are as follows:

3.5.1 Experimental rig for preparing carbon adsorbent

In this project, there are 2 methods of experimental rig for preparing carbon adsorbent. One of the methods used the old design and another one method used the new design of reactor. Both of the design is using different techniques.

3.5.2 Preparation of Carbon Adsorbent Using the Conventional Method

The first stage is preparing the samples of oil palm shell. Oil palm shells are crushed and sieved into a size of 250-425 μm separately. The granular formed are being used. About 50 g of the samples were fed into the reactor. Next is to prepare the carbon adsorbent from oil palm shell using below experimental rig.



Figure 3.12 Sieve of size 250-425 μm



Figure 3.13 Sample of granular



Figure 3.14 Sample of particles



Figure 3.15 Sample of powder

The experimental rig for preparing carbon adsorbent consists of:

1. Reactor (current design)
2. Tube furnace and heater
3. Suction blower
4. Nitrogen and carbon gas tank
5. Control meter of gas flow rate
6. Other accessories
7. Cylinder test bed
8. LPG tank



Figure 3.16 Current design of reactor



Figure 3.17 Suction blower



Figure 3.18 Nitrogen and carbon dioxide gas tank



Figure 3.19 Control meter of gas flow rate

The procedures of preparing the carbon adsorbent are as below:

1. About 50 g of sample were fed into the reactor.
2. The furnace and suction blower is switched on.
3. The nitrogen gas tank is opened into 200 bars and the flow rate of N_2 is adjusted at 1.5 l/min.
4. Furnace is being set for 700°C at $10^\circ\text{C}/\text{min}$ of heating rate.
5. N_2 was injected to the reactor for an hour. After an hour, N_2 was maintained at 700°C of temperature and the flow is closed after 60 minutes.
6. Next, the carbon dioxide tank was opened into 7500 bars and the flow rate of CO_2 is adjusted at 0.4 l/min.
7. CO_2 was injected to the reactor for an hour. Then, the gas is maintained at correspond temperature and the flow is closed after 60 minutes.
8. The temperature is turned to 30°C and the sample is being cooled.
9. Finally, the sample is being weighed.

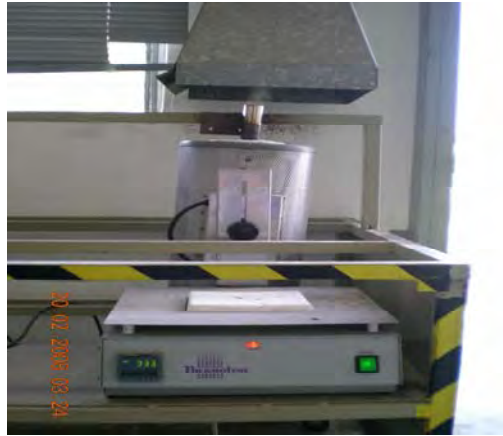

Figure 3.20 Process of using the conventional method



Figure 3.21 Sample is being weighed

3.5.3 Preparation of Carbon Adsorbent Using the Compression Method

In this method, the carbon adsorbent was prepared without using both nitrogen and carbon dioxide gases. As was mentioned before, this method is using the compression concept. The granular formed are also being used and about 50 g of the samples were fed into the reactor. Next is to prepare the carbon adsorbent from oil palm shell by using below experimental rig.

The experimental rig for preparing carbon adsorbent consists of:

1. Reactor (new design)
2. Tube furnace and heater
3. Suction blower
4. Hydraulic jack
5. Force gauge
6. Other accessories



Figure 3.22 New design of reactor



Figure 3.23 Hydraulic jack



Figure 3.24 Top plate

The procedures of preparing the carbon adsorbent in this method are as below:

1. About 50 g of sample were fed into the reactor.
2. Reactor is admitted into the tube furnace and by using the hydraulic jack; its position has to be made sure at a middle of furnace and the top part is contact to the plate.
3. The force gauge is located between the jack and reactor. Reading at initial state is being taken.

4. The furnace and suction blower is switched on.
5. The temperature of furnace is set at 300°C and the process was maintained for 2 hours after the temperature has been reached.
6. The temperature is turned to 30°C and the sample is being cooled.
7. Finally, the sample is being weighed.
8. If the top part is no longer contact to the plate due to the weight reduction of sample, jack must be lifted until the top part hit the surface of the plate in order to let it compress the sample. Readings of force are being taken.
9. The experiment is being repeated with 400°C and 500°C of temperatures.



Figure 3.25 Process using compression method



Figure 3.26 Top view of the process using compression method



Figure 3.27 Location of force gauge

3.5.4 Preparation of Testing the Performance of Carbon Adsorbent in LPG tank

After preparing the carbon adsorbent with both methods, all the samples are being tested by using Cylindrical Test Bed (CBT) to determine the its adsorption and desorption capacities using the gravimetric method when introduced by a certain gas. The device in this experiment consists of:

1. Cylinder with 30 mm inner diameter and 150 mm length
2. Pressure gauge, which is attached to the cylinder
3. Digital balance in the range of 0.0 – 3000.0 grams
4. Vacuum generator to vacuum the cylinder
5. Gas feeder which is LPG

The first step undertaken was to determine the amount of gas in the empty cylinder by weighing the cylinder before and after feeding the gas. Next was to fill the cylinder with carbon adsorbent (sample of 300°C, 400°C, 500°C and 700°C), and to determine the amount of gas adsorbed in the carbon adsorbent by weighing the cylinder before and after feeding the gas. In this experiment, the LPG was feed into the cylinder at 2 bar (gauge) and 24.8°C (air conditioned room temperature) condition.



Figure 3.28 Cylindrical test bed on the digital balance



Figure 3.29 LPG's tank that used in adsorption test

3.6 Problem analysis and solution

In this project, there are many possibilities had been identified.. The possibilities of the project are as below:

1. The compression method is not efficient
2. New design is not suitable
3. Possible to generate any gases when heating process such as oxygen (O_2)

Solutions for the problems above is to well prepared the experimental rig for this project and make some adjustment on the design until a satisfy result is achieved.

CHAPTER 4

RESULTS AND DATA ANALYSIS

4.1 Experiment 1: Preparing the Carbon Adsorbent Using Conventional Method

The table 4.1 below showed the weight of samples after the pyrolysis process at temperature of 700°C with used of nitrogen and carbon dioxide gases. The process is being repeated with 5 samples in a same weight which is 50 g. It is noticed that, after the process all the samples had experience in weight reduction. All samples had almost similar weight change rate except for sample 1 that might be less much caused of the increasing of pressure gas supplied to it eventually, thus had rejected the sample outwards reactor and left insufficient amount.

Table 4.1: Weight of samples at 700°C after pyrolysis process

SAMPLE	TEMPERATURE (°C)	WEIGHT (g)
1	700	5.57
2	700	14.18
3	700	13.30
4	700	13.27
5	700	14.28

Figure 4.1 below has shown the graph of weight changes for all samples before and after the process. The weight changes after the pyrolysis process indicates that when temperature is high, the weight loss will be increase due to the most of the volatile matters in sample.

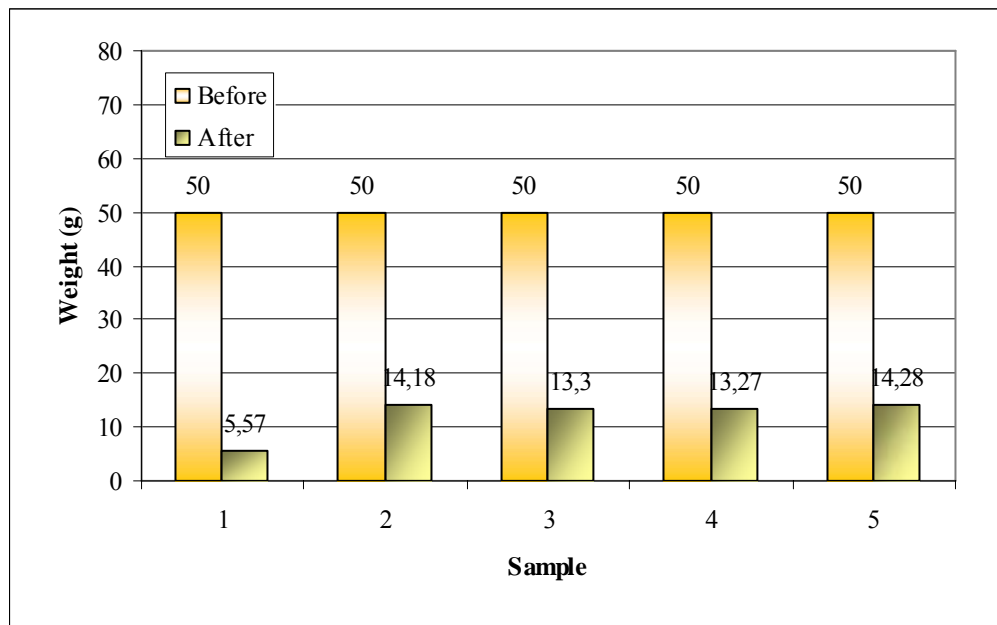

Figure 4.1 Graph of weight changes for samples in conventional method

4.2 Experiment 2: Preparing the Carbon Adsorbent Using Compression Method

Table 4.2 below showed the weight and the force of the samples at different temperature which is 300°C, 400°C and 500°C. In this experiment, no gases had been supplied and the process is using the compression concept. From the analysis, at 300°C of temperature has 1.1 N forces applied thus produce 23.4 g from 50 g of carbon adsorbent. Different for temperature at 400°C and 500°C which has more force applied with 1.6 N and 1.95 N respectively. At temperature of 500°C had experience much in weight reduction compared to others two. This mean that at high temperature, more force is applied due to the reduction of weight sample.

Table 4.2: Weight and Force of samples at different temperature

SAMPLE	TEMPERATURE (°C)	MAXIMUM FORCE (N)	WEIGHT (g)
1	300	1.10	23.4
2	400	1.60	17.7
3	500	1.95	15.5

Figure 4.2 (a) is a graph of force against the temperature. The temperature at 500°C has higher force applied. Next is at temperature of 400°C with force applied 1.6 N and the lowest is at 300°C with 1.1 N value of force. This indicates that the force will be increase whenever the temperature is greater.

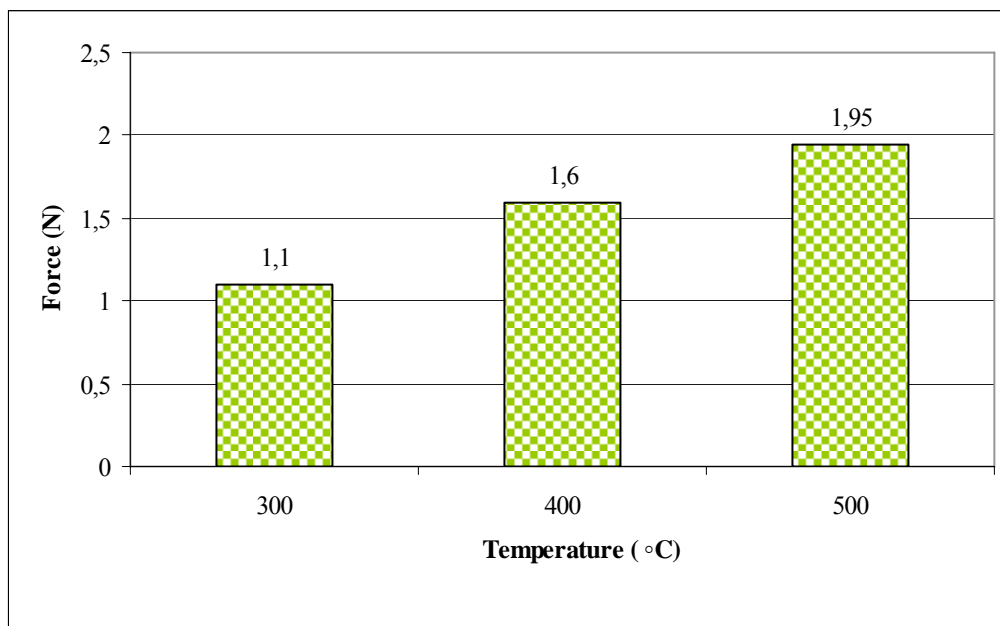

Figure 4.2 (a) Graph of force against the temperature in compression method

Figure 4.2 (b) is a graph of weight samples against the temperature after the process occur. The highest weight remains after the process was at 300°C with 23.4 g while the lowest weight remains after the process was at 500°C. This means that, less temperature will burn off fewer samples thus remain more amount of carbon adsorbent.

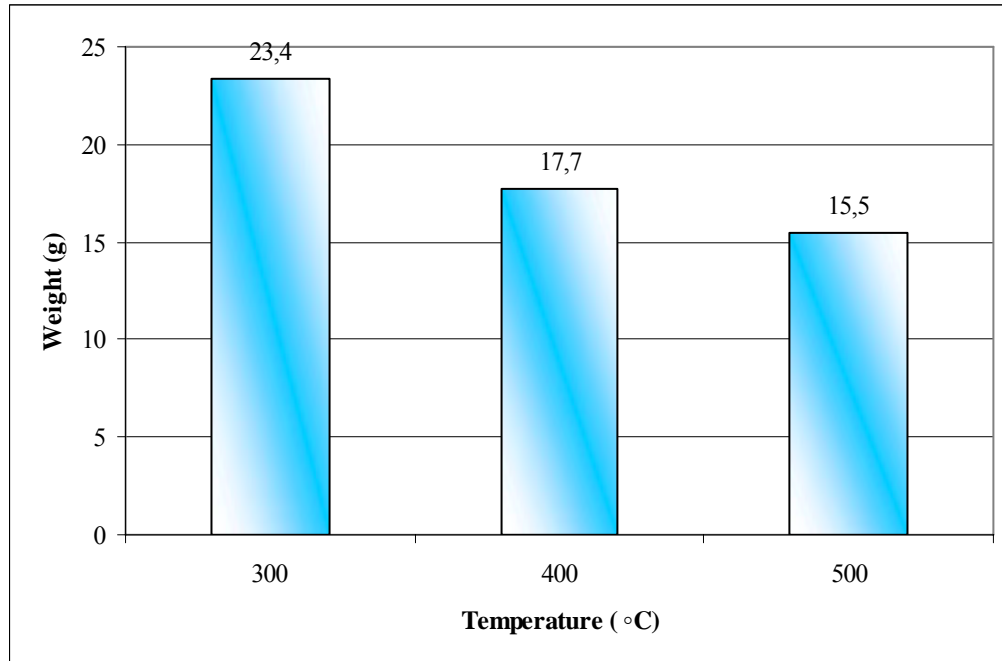

Figure 4.2(b) Graph of weight against temperature in compression method

Figure 4.2 (c) is a graph of weight changes at different temperature. In this process, weight loss will be increase at higher temperature as shown in the graph below. At temperature of 500°C, the weight of sample experience more weight loss after the process. This is happen due to the method used as the process is not using the nitrogen gas to obtain an inert atmosphere in reactor. Without the gas, the burning process will occur and therefore more samples will be burn off and remain less weight.

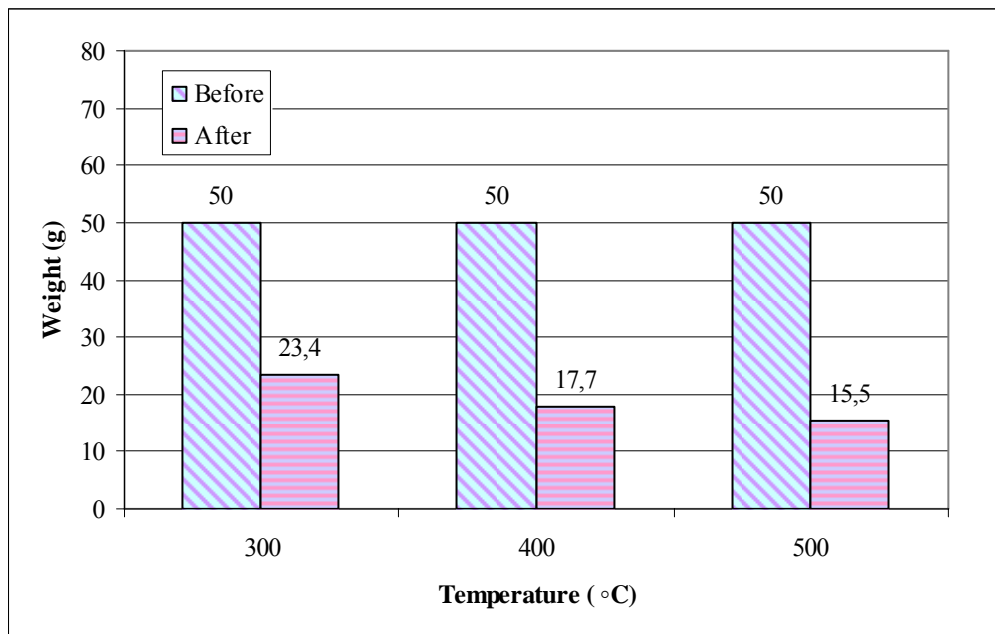

Figure 4.2 (c) Graph of weight changes at different temperature in compression method

4.3 Experiment 3: Testing the Performance of Carbon Adsorbent in LPG tank

Table 4.3 showed the weight of gas adsorbed for various sample due to the different temperature. At temperature of 300°C, gas had adsorbed by carbon adsorbent with 0.5 g at room temperature of 24.8°C. While for the sample of 400°C, the gas had been adsorbed with 0.7 g at the same temperature of sample 300°C. By increasing of the temperature sample in this process, the gas adsorbed had been increased either. This has been improved when the carbon adsorbent is processed at temperature of 500°C and 700°C where the weight of gas adsorbed for both sample are 1.0 g and 1.8 g respectively.

Table 4.3: Weight of gas adsorbed for various sample due to the different temperature

SAMPLE (°C)	ROOM TEMPERATURE (°C)	WEIGHT of SAMPLE (g)	WEIGHT of CYLINDER CONTAINED SAMPLE AND GAS (g)	WEIGHT of GAS ADSORBED
300	24.8	10.3	963.9	0.5
400	24.8	10.3	963.8	0.7
500	24.5	10.8	964.6	1.0
700	27.0	10.2	964.8	1.8

Weight of empty cylinder: 952.8 g

Weight of cylinder after feeding gas with maximum pressure of 2 bars: 955.2 g

Weight of feeding maximum gas: $955.2 \text{ g} - 952.8 \text{ g} = 2.4 \text{ g}$

Weight of gas adsorbed = (Weight of cylinder with sample and gas) – (Weight of cylinder with sample)

For example;

Weight of cylinder with sample of 500°C and gas = 964.6 g

Weight of cylinder with sample of 500°C = $952.8 \text{ g} + 10.8 \text{ g} = 963.6 \text{ g}$

Weight of gas adsorbed = $964.6 \text{ g} - 963.6 \text{ g} = 1.0 \text{ g}$

Figure 4.3 (a) below is a result of adsorption process for the samples of both method. From this figure, the graph showed that, the highest of weight gas adsorbed for compression method is at the higher temperature which is 500°C in this case. But for the temperature at 300°C, the weight of gas adsorbed is less than the highest temperature. For the bar of conventional method which is at 700°C, gas is adsorbed with 1.8 g which is the highest weight of gas adsorbed among the method used. This indicates that, the higher temperature of the process the more gas will be adsorbed.

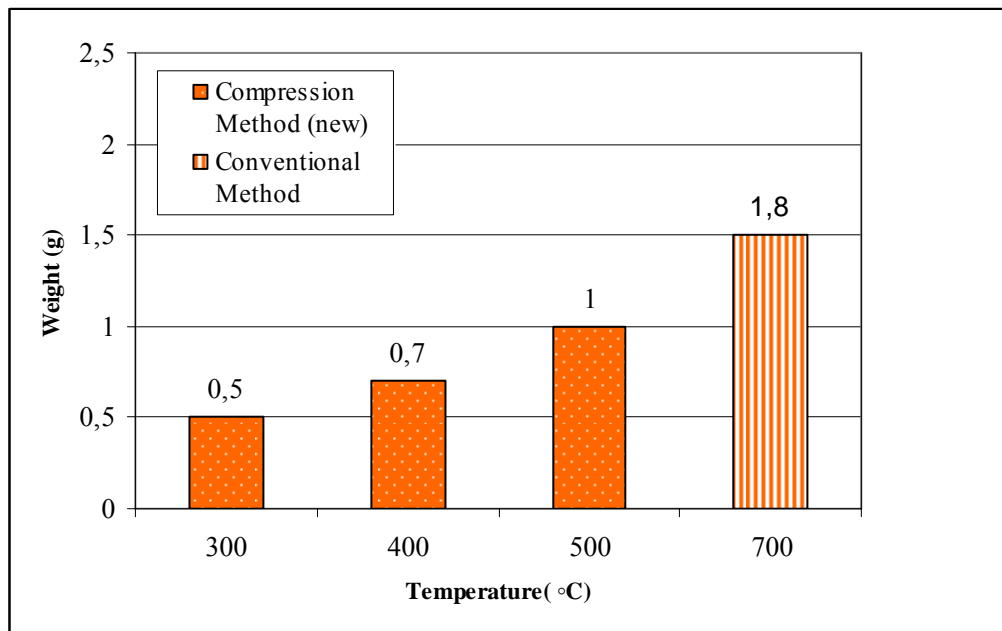

Figure 4.3 (a) Graph of weight for gas adsorbed against different temperatures.

Figure 4.3 (b) below shown the graph of weight change for all samples either in pyrolysis or compression process. From this figure, the highest of weight loss is at 700°C of temperature which is from pyrolysis process. In the other hand, weight that remains after that process is less for 14.28 g. While the lowest weight loss in this graph is at 300°C which is remain the weight of the sample with 23.4 g. In this case, the process is using the compression method. Even the sample had less weight loss compare to the others, another comparison can be made between the highest temperatures in different methods.

From the pyrolysis process, the temperature at 700°C has weight of sample with 14.28 g compared to the temperature at 500°C from different process which has 15.5 g. Even the weight loss at 700°C is more than at 500°C; the value has not much different. It is predicted that if the temperature of sample from compression method will be extend the weight loss also will be higher same as or greater than the sample from pyrolysis process. This is because more samples will be burn off caused of no nitrogen gas to control the burning and thus the weight loss rapidly.

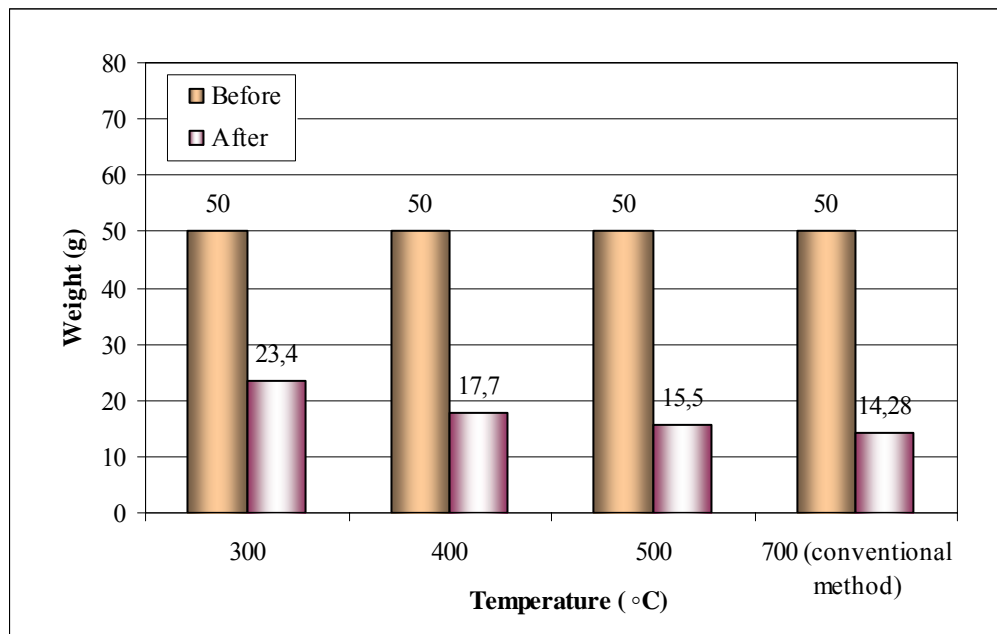

Figure 4.3 (b) Graph of weight changes for all samples

CHAPTER 5

DISCUSSIONS

From this experimental result, both of conventional method (pyrolysis process) and compression method are being compared. There are lots of different between these two methods either from the design and preparation of the carbon adsorbent or the results that had been achieved.

The conventional method that involves the pyrolysis process has used the nitrogen and carbon dioxide gas as the catalyst of the process. Nitrogen gas is used to obtain an inert atmosphere in reactor. The reaction between the nitrogen and the sample mostly carbon will prevent from exists of an oxygen gas thus to encourage burning process. This might cause the weight loss of the sample of carbon adsorbent. Besides, the carbon dioxide is used to activate the sample. Although the catalysts assist in the process, sometimes it is hardly to control the flow and the gas is quite costly.

In this process the char was prepared at 700°C. In the case of high temperature, the weight loss will be increased due to the burning of volatile matter that produces ash. Even the carbon adsorbent are prepared at high temperature, the characteristic of the carbon adsorbent will be greater. Carbon adsorbent will adsorb more gas at high temperature. This thing happens due to the new microporosities have been developed as more volatile matters were released.

The next method of preparing carbon adsorbent is the compression method. This method is simply prepared because it is not using any gases. The concept is to compress the sample along the process with differences temperature. As the first method, this method also experiences weight loss of carbon adsorbent. As well as the method was prepared at high temperature, more burning process will occur. It is observed that

flaming is occurred during burning of carbon adsorbent at temperature of 500°C (see figure 5.1). This thing happens due to no gases supplied to control the burning as what the first method did. Moreover, weight loss in this method will be increase. More force also will be applied so that the samples keep compressed. It is noticed that, the carbon adsorbent produced in this process were also adsorb more gas at high temperature. At high temperature, the carbon adsorbent will develop more pores thus it has capability to adsorb more gases.

Furthermore, it is observed that the ambient temperature of surroundings is one of the factors that influence the rate of adsorption process. The lower the temperature, the greater gas is being adsorbed. The performance of carbon adsorbent in adsorption process can be determined by testing large amount of carbon adsorbent in cylindrical test bed so that the weight of gas adsorbed is clearly identified. The use of digital balance to weight the gas is less precise and cause the results of testing was not appropriate.



Figure 5.1 Flaming occurred at temperature 500°C by using the compression method

CHAPTER 6

CONCLUSION

Basically in this project, the process of preparing a carbon adsorbent has been achieved. The performance of carbon adsorbent can be identified through its preparation. There are two process of preparing carbon adsorbent in this project which is using the conventional method and the compression method.

The conventional method is the method that involves the pyrolysis process by using the nitrogen and carbon dioxide gases. This method was prepared the char at higher temperature which is at 700°C. While the compression method is simply prepared without uses any gases. This method was prepared at differences temperature which is at 300°C, 400°C and 500°C. From the results of preparing carbon adsorbent with both methods, it shows that greater adsorption gas is contributed by the adsorbent that was prepared at higher temperature. This means that carbon adsorbent was adsorbed more gases at 700°C of conventional method and at 500°C of compression method. This is happens because of more pores have been developed and encouraged the adsorption gas.

Even both process were successfully prepare the effective carbon adsorbent, results show that the conventional method is better than the compression method. This is because more gas has been adsorbed by the carbon adsorbent prepared from the conventional method. Moreover, the char that was prepared by conventional method is better than the other method. The particles are also looking finer and smoother. This might be caused of the process that has been control by the gases. In order to achieve the greater adsorption of gas, the temperature in compression method has to be extended. Somehow, the sample was burning off badly at temperature of 500°C and it is

unpredictable to observe what will happen if the temperature being extended. So as a conclusion, the conventional method is being preferred to produce the carbon adsorbent that can be used in LPG tank.

Based on this project, there are several recommendations for the next researches.

The recommendations are as follows:

1. Design and develop more effective experimental rig for preparing better carbon adsorbent.
2. All form of samples must be tested to determine the adsorption capacities of the samples.
3. Produce more sample of carbon adsorbent in order to achieve better results in experiment
4. Prepare carbon adsorbent from various waste materials such as coconut shell.

REFERENCES

1. Barry, F., Gin, L., and Cameron, F. (2007). "Process for producing activated carbon" (U.S. Patent 7199080)
2. Donnet, J.B., Qin, R.Y., Ryu, S.K., Park, S.J, and Rhee, B.S (1993). "Study of Scanning Tunneling Microscopy on Activated Carbon Fibers".
3. Eddie, D.D. (1998). "The Effect of Processing on the Structure and Properties of Carbon Fibers". *Journal of Carbon*, 36:345-362.
4. El-Merroui, M., Tamai, H., Yasada, H., Kamata, T., Mandori, J., and Nadai, K. (1998). "Pore Structures of Activated Carbon Fibers from Organicmetallics/Pitch Composites by Nitrogen Adsorption", *Journal of Carbon* 26: 1769-1776.
5. Herawan, S.G (2006). "The Comparison of LPG and Natural Gas Adsorption Capacity In Carbon Adsorbent" .Universiti Teknikal Malaysia Melaka: Thesis.
6. Krezil, F (1937). "Production of activated carbon" (U.S. Patent 2,083,303).
7. Laine, J. and Calafat (1991). "Factors affecting the preparation of activated carbon from coconut shells catalized by potassium". *Carbon* 29 : 949-953.
8. Lourens, C. (1931). "Process of treating active carbons for increasing their adsorbing efficiency". (U.S. Patent 1,788,466).

9. L.S Frank (1985. “Adsorption Technology A Step-by-Step Approach to Process Evaluation and Application”
10. Marsh, H and Rodriguez-Reinoso, F (2006). “Activated Carbon”. Elsevier Ltd. pg 143-242
11. Mattson, J.S. and H.B, Mark, Jr. (1971). “Activated Carbon” New York:Dekker.
12. Rodriguez-Reinoso, F., M. Molina-Sabio and M.T, Gonzalez (1992). “The use of steam and CO₂ as activating agents in the preparation of activated carbons”. *Carbon* 33: 15-23
13. Stoeckli, H.F. (1990). “ Microporous carbons and their characterization present state of the art”. *Carbon* 28 :1-6
14. Von Blucher, H. and E, De Ruiter (1999). “Process for producing granulated activated carbon”. (U.S. Patent 5,977,016)
15. Wellen, C.W., D.K, Stephens and G.R Wellen (1997).”Method of producing activated carbon” (U.S. Patent 5,858,911)
16. <http://en.wikipedia.org/wiki/activatedcarbon>
17. <http://en.wikipedia.org/wiki/activation>
18. <http://en.wikipedia.org/wiki/carbonization>
19. <http://en.wikipedia.org/wiki/pyrolysis>
20. <http://en.wikipedia.org/wiki/adsorption>

21. <http://www.tigg.com>
22. [http://www.e-lpg.com/propane&butane-liquefiedpetroleumgas\(LPG\)](http://www.e-lpg.com/propane&butane-liquefiedpetroleumgas(LPG))

APPENDICES

Just the Basics

Liquefied Petroleum Gas

Although it is a fossil fuel, liquefied petroleum gas can help enhance the energy security of the United States and other significant emissions benefits. Commonly called propane, it is the most popular alternative fuel in the world.

What Is Liquefied Petroleum Gas?

More than 350,000 light-and medium-duty vehicles travel the nation's highways using liquefied petroleum gas (LPG or LP gas), while over 4 million vehicles use it worldwide. LPG is a mixture of several gases that is generally called "propane," in reference to the mixture's chief ingredient. LPG changes to the liquid state at the moderately high pressures found in an LPG vehicle's fuel tank.

LPG is formed naturally, interspersed with deposits of petroleum and natural gas. Natural gas contains LPG, water vapor, and other impurities that must be removed before it can be transported in pipelines as a salable product. About 55% of the LPG processed in the U.S. is from natural gas purification. The other 45% comes from crude oil refining. Since a sizable amount of U.S. LPG is derived from petroleum, LPG does less to relieve the country's dependency on foreign oil than some other alternative fuels. However, because over 90% of the LPG used here is produced here, LPG does help address the national security component of the nation's overall petroleum dependency problem.

What Are the Emissions Benefits of LPG?

Propane vehicles emit about one-third fewer reactive organic gases than gasoline-fueled vehicles. Nitrogen oxide and carbon monoxide emissions are also 20% and 60% less, respectively. Unlike gasoline-fueled vehicles, there are no evaporative emissions while LPG vehicles are running or parked, because LPG fuel systems are tightly sealed. Small amounts of LPG may escape into the atmosphere during refueling, but these vapors are 50% less reactive than gasoline vapors, so they have less of a tendency to generate smog-forming ozone. LPG's extremely low sulfur content means that the fuel does not contribute significantly to acid rain.

LPG Is a Good Fuel for Fleet Service

Many propane vehicles are converted gasoline vehicles. The relatively inexpensive conversion kits include a regulator/vaporizer that changes liquid propane to a gaseous form and an air/fuel mixer that meters and mixes the fuel with filtered intake air before the mixture is drawn into the engine's combustion chambers. Also included in conversion kits is closed-loop feedback circuitry that continually monitors the oxygen



Less dependence on foreign oil, and eventual transition to an emissions-free, petroleum-free vehicle

Propane Production

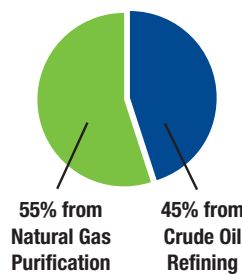

Vehicle Emissions

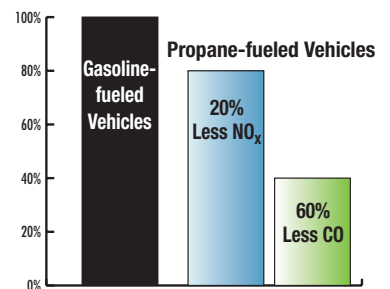

vehicle systems

content of the exhaust and adjusts the air/fuel ratio as necessary. This device communicates with the vehicle's onboard computer to keep the engine running at optimum efficiency. LPG vehicles additionally require a special fuel tank that is strong enough to withstand the LPG storage pressure of about 130 pounds per square inch. The gaseous nature of the fuel/air mixture in an LPG vehicle's combustion chambers eliminates the cold-start problems associated with liquid fuels. In contrast to gasoline engines, which produce high emission levels while running cold, LPG engine emissions remain similar whether the engine is cold or hot. Also, because LPG enters an engine's combustion chambers as a vapor, it does not strip oil from cylinder walls or dilute the oil when the engine is cold. This helps LPG-powered engines to have a longer service life and reduced maintenance costs. Also helping in this regard is the fuel's high hydrogen-to-carbon ratio (C_3H_8), which enables propane-powered vehicles to have less carbon build-up than gasoline- and diesel-powered vehicles.

LPG delivers roughly the same power, acceleration, and cruising speed characteristics as gasoline. It does yield a somewhat reduced driving range, however, because it contains only about 70-75% of the energy content of gasoline. Its high octane rating (around 105) means, though, that an LPG engine's power output and fuel efficiency can be increased beyond what would be possible with a gasoline engine without causing destructive "knocking." Such fine-tuning can help compensate for the fuel's lower energy density.

Fleet owners find that propane costs are typically 5% to 30% less than those of gasoline. The cost of constructing an LPG fueling station is also similar to that of a comparably sized gasoline dispensing system. Fleet owners not wishing to establish fueling stations of their own may avail themselves of over 3,000 publicly accessible fueling stations nationwide.

How Safe Is LPG?

Propane is an odorless, nonpoisonous gas that has the lowest flammability range of all alternative fuels. High concentrations of propane can displace oxygen in the air, though, causing the potential for asphyxiation. This problem is mitigated by the presence of ethyl mercaptan, which is an odorant that is added to warn of the presence of gas. While LPG itself does not irritate the skin, the liquefied gas becomes very cold upon escaping from a high-pressure tank, and may therefore cause frostbite, should it contact unprotected skin.

As with gasoline, LPG can form explosive mixtures with air. Since the gas is slightly heavier than air, it may form a continuous stream that stretches a considerable distance from a leak or open container, which may lead to a flashback explosion upon contacting a source of ignition.

fuels & lubricants

emission control

A Strong Energy Portfolio for a Strong America

Energy efficiency and clean, renewable energy will mean a stronger economy, a cleaner environment, and greater energy independence for America. Working with a wide array of state, community, industry, and university partners, the U.S. Department of Energy's Office of Energy Efficiency and Renewable Energy invests in a diverse portfolio of energy technologies.



U.S. Department of Energy
Energy Efficiency
and Renewable Energy

August 2003

Printed on recycled paper

[Login or Create Free Account](#)Search [Go to Advanced Search](#)[Home](#) | [Search Patents](#) | [Data Services](#) | [Help](#)

Title:

Process for producing activated carbon

Document Type and Number:

United States Patent 7199080

Link to this page:

<http://www.freepatentsonline.com/7199080.html>

Abstract:

A method of producing activated carbon comprising the steps of a) pyrolysing corn derivatives to generate char and b) activating the char to produce activated corn carbon.

[Ads by Google](#)

[Wastewater Treatment](#)

Industrial Effluents Municipal Wastewaters

www.veoliawaterst.com

[Greenhouse Gas](#)

Get Greenhouse Gas info for free, from IndustryWeek

www.IndustryWeek.com

[Separation Technology](#)

Membrane Technology Evaporation Systems

www.hydaire.com

[Membrane China](#)

Alibaba B2B online marketplace. Forbes Magazine Best of the Web.

www.Alibaba.com

[Horizontal & Vertical](#)

Pressure Leaf Filters. Hi Tech Design W/ Low Cost.

Visit Us Today!

www.abhishekfilter.com/LeafFilter

Representative Image:

www.greenlineindustries.com

Air and Water filters

We provide products and services to air / water filtration system needs

www.globemate.com.my

Carbon Filtration

Carbon Filtration explained. Find Everything You Need To Know.

WaterTreatment.Machines-Direct.com

Integrated Pyrolysis

Inorganic & Organic Waste Solutions Renewable Resource Recovery

www.kleanindustries.com

Amcec

Carbon Adsorption Solvent Recovery Systems

www.amcec.com

Purification Systems

Produce USP Grade Glycerin Proprietary, Low Cost Technology

www.artisanind.com

Carbon fiber

Carbon fiber ,Carbon fiber cloth Kevlar fabric

www.cn-txw.com

Ads by Google

Biodiesel Process Equip

Water Free processing equipment 3 to 60 million gallons-Plant Tours

www.greenlineindustries.com

Air and Water filters

We provide products and services to air / water filtration system needs

www.globemate.com.my

Carbon Filtration

Carbon Filtration explained. Find Everything You Need To Know.

WaterTreatment.Machines-Direct.com

Integrated Pyrolysis

Inorganic & Organic Waste Solutions Renewable Resource Recovery

www.kleanindustries.com

Amcec

Carbon Adsorption Solvent Recovery Systems

www.amcec.com

Purification Systems

Produce USP Grade Glycerin Proprietary, Low Cost Technology

www.artisanind.com

Carbon fiber

Carbon fiber ,Carbon fiber cloth Kevlar fabric

www.cn-txw.com

Ads by Google

Biodiesel Process Equip

Water Free processing equipment 3 to 60 million gallons-Plant Tours

5/6/2008 11:12 A

www.greenlineindustries.com

Air and Water filters

We provide products and services to air / water filtration system needs

www.globemate.com.my

Carbon Filtration

Carbon Filtration explained. Find Everything You Need To Know.

WaterTreatment.Machines-Direct.com

Integrated Pyrolysis

Inorganic & Organic Waste Solutions Renewable Resource Recovery

www.kleanindustries.com

Amcec

Carbon Adsorption Solvent Recovery Systems

www.amcec.com

Purification Systems

Produce USP Grade Glycerin Proprietary, Low Cost Technology

www.artisanind.com

Carbon fiber

Carbon fiber ,Carbon fiber cloth Kevlar fabric

www.cn-txw.com

Inventors:

Freel, Barry (Ontario, CA)
Liaw, Gin (Decatur, IL, US)
Ferguson, Cameron (Forsyth, IL, US)

Application Number:

10/463030

Filing Date:

06/17/2003

Publication Date:

04/03/2007

View Patent Images:

Referenced by:

Images are available in PDF form when logged in. To view PDFs, [Login](#) or [Create Account \(Free!\)](#) [View patents that cite this patent](#)

Export Citation:

[Click for automatic bibliography generation](#)

Assignee:

STALEY MFG CO A E (US)

Primary Class:

[502/423](#)

Other Classes:

502/432

International Classes:

C01B31/10

Field of Search:

502/432, 502/423, 502/436, 502/437

US Patent References:

[4745015](#) May, 1988 Cheng et al. 428/35.8 Thermal insulating panel

5/6/2008 11:12 A

<u>5187141</u>	February, 1993	Jha et al.		Process for the manufacture of activated carbon from coal by mild gasification and hydrogenation
<u>5726118</u>	March, 1998	Ivey et al.	502/417	Activated carbon for separation of fluids by adsorption and method for its preparation
<u>5792340</u>	August, 1998	Freel et al.		Method and apparatus for a circulating bed transport fast pyrolysis reactor system
<u>5853548</u>	December, 1998	Piskorz et al.		Energy efficient liquefaction of biomaterials by thermolysis
<u>5961786</u>	October, 1999	Freel et al.		Apparatus for a circulating bed transport fast pyrolysis reactor system
<u>6030922</u>	February, 2000	Khalili et al.		Synthesizing carbon from sludge
<u>6251822</u>	June, 2001	Peng et al.		Method of making activated carbon derived from pitches

Foreign References:

RU2124547	January, 1999			
WO/2000/000429	January, 2000			A PROCESS FOR PREPARING ACTIVATED CARBON FROM URBAN WASTE
WO/2001/049604	July, 2001			A PROCESS FOR PREPARING ACTIVATED CARBON FROM URBAN WASTE

Other References:

- Rostam-Abadi, M., Chang, R. Chen, S., Lizzio, T., Richardson, C., and Sjostrom, S., 2001, "Final Technical Report: Demonstration Of Sorbent Injection Process For Illinois Coal Mercury Control". Illinois Clean Coal Institute, Project No. 00-1/2.2D-1.
- Chang, C-F., Chang, C-Y., and Tsai, W-T., "Effects of burn-off and activation temperature on preparation of activated carbon from corn cob agrowaste by CO₂ and steam", Journal of Colloid and Interface Science, 232, pp. 45-49, (2000).
- Ullmann's Encyclopedia of Industrial Chemistry, "Carbon" Chapter, section 5.3.4.2, Wiley, Jan. 15, 2002.
(<http://www.mrw.interscience.wiley.com/ueic/articles/a05—095/sect5-fs.htm>)
- "Corn Refining: The Process, The Products," Corn Refiners Association, Inc., Brochure, 1992.
- "Corn Wet Milled Feed Products," Corn Refiners Association, Inc., 3rd Ed., 1989.
- "Corn Starch," Corn Refiners Association, Inc., 9th Ed., 1994.

Primary Examiner:

Hendrickson, Stuart

Attorney, Agent or Firm:

Brinks Hofer Gilson & Lionie

Parent Case Data:

This application claims the benefit of U.S. Provisional Application No. 60/389,478, filed Jun. 17, 2002, under 35 U.S.C. § 119(e).

Claims:

The embodiments of the invention in which an exclusive property of privilege is claimed are defined as follows:

1. A method of producing activated carbon comprising the steps of: a) pyrolysing corn derivatives in the presence of an inorganic particulate heat supplying material at a temperature of between about 460° C. to about 560° C. and a weight ratio of the inorganic heat supplying material to the corn derivatives from about 12:1 to about 200:1, for a duration of about 0.03 to about 2 seconds, to produce char, and b) activating said char using steam at a temperature of between about 500° C. to about 1000° C. and a steam to carbon ratio of about 0.4:1 to about 7:1 for a duration of between about 10 to about 90 minutes, to produce activated carbon.
2. The method of claim 1, further comprising a pelletization step wherein said char is mixed with a binder selected from the group consisting of starch, molasses, coal tar, natural resin, wood based natural resin, corn based natural resin or a combination thereof.
3. The method of claim 1, wherein said pyrolysis is performed for a duration of about 0.7 seconds.
4. The method of claim 1, wherein said steam is at a temperature of about 800° C. to about 1000° C.
5. The method of claim 1, wherein said steam to carbon ratio is about 0.4:1 to about 1.7:1.
6. The method of claim 1, wherein said activating comprises a duration of between 30 to about 90 minutes.
7. The method of claim 1, wherein said corn derivatives comprise corn kernels, off grade corn kernels, corn cobs, corn fiber, corn hulls, corn stover, corn steep liquor, gluten, starch or any combination thereof.
8. The method of claim 7, wherein said corn derivative comprises a dried mixture of corn steep liquor and corn fiber produced during the wet milling of corn.
9. A method of producing activated carbon comprising the steps of: a) pyrolysing corn derivatives in the presence of an inorganic particulate heat supplying material at a temperature of between about 350° C. to about 560° C. and a weight ratio of the inorganic heat supplying material to the corn derivatives from about 12:1 to about 200:1, for a duration of about 0.3 seconds to about 2 minutes, to produce char, and b) activating said char using steam at a temperature of between about 500° C. to about 1000° C. and a steam to carbon ratio of about 0.4:1 to about 7:1 for a duration of between about 10 to about 90 minutes, to produce activated carbon.
10. The method of claim 9, wherein said char, activated carbon, or both are

acid-washed.

11. The method of claim 10, wherein said acid wash comprises soaking in an acidic solution followed by dewetting.

12. The method of claim 11, wherein said acidic solution comprises hydrochloric, sulfuric, nitric, acetic, formic or pyrolytic acid solution.

13. The method of claim 12, wherein said solution comprises between about 0.2 to about 5% (v/v) acid.

14. The method of claim 13, wherein said acid is hydrochloric acid, sulfuric acid or a combination thereof.

15. The method of claim 11, wherein said dewetting is performed by centrifugation, vacuum drum, filtering or a combination thereof.

16. The method of claim 11, wherein said acid wash is followed by rinsing with water.

Description:

The invention relates to methods of producing activated carbon and to products produced according to the method. More specifically, the present invention relates to a method of producing activated carbon from corn, corn fiber, corn derivatives and corn fiber derivatives and to products produced according to the method.

BACKGROUND OF THE INVENTION

Activated carbon is well-known in the art for its ability to remove impurities from solutions. Further, many processes have been described to produce activated carbon. For example, WO 01/49604 discloses a process for preparing activated carbon from urban waste. The process comprise sorting the waste to remove foreign materials, reducing the size of the waste particles, drying the waste under anaerobic conditions, pyrolysing the waste at a temperature above 110° C. to obtain a powdery charcoal product, agglomerating the charcoal product, carbonizing the agglomerated particles at a temperature above 110° C., activating the agglomerated particles by subjecting the particles to steam and CO₂ at a temperature in the range of about 750° C.–900° C., purifying and rinsing the particles in an aqueous acidic solution and subsequently with water, and drying the activated carbon particles. The process allegedly produces activated carbon having a low ash content, high pore volume and improved hardness over other activated carbons known in the art.

RU 2122547 discloses a pyrolytic process that uses agricultural wastes such as straw, corn husks, millet, rice, and cotton to produce activated carbon. Pyrolysis is performed at 650° C. to about 950° C. under a reducing gas atmosphere. Subsequently, the pyrolysis product is treated

with steam at a temperature above 500° C. at a steam to material weight ratio of (0.01–0.05):1.

WO 00/00429 discloses a process for preparing activated carbon from urban waste. The process comprises the steps of sorting the waste to remove foreign materials and reducing the size of the waste. The waste is dried under aerobic conditions at a temperature of about 100–150° C. and partially pyrolyzed at a temperature of about 140–400° C. The product is subsequently granulated and the granules are carbonized under anaerobic conditions at a temperature of about 120–500° C. Subsequently, the granules are activated by steam and combustion gasses at 750–900° C. Finally, the activated granules are purified by rinsing in aqueous HCL solution and dried.

U.S. Pat. No. 6,251,822 discloses a method of making activated carbon of various pore size distributions. The method comprises carbonizing activated pitch, wherein the softening point of the pitch is less than about 250° C. and activating the pitch to produce activated carbon. The patent also teaches that a catalyst metal may be employed to produce mesoporosity in the activated carbon.

U.S. Pat. No. 6,030,922 discloses synthesizing activated carbon from sludge such as biosolids. The treated material is subjected to chemical activation, light and humidity treatment, pyrolysis and physical activation to produce an activated carbon having a high surface area and microporosity.

Although the all of the documents referred to above disclose a method of producing activated carbon, the products produced by these products will differ widely in terms of their physical structure and absorption characteristics, as these characteristics are dependent on the type of starting material and its condition, and the processing conditions which are employed to produce activated carbon. Thus, the activated carbons may exhibit marked variation in their hardness, ash content, porosity, and binding/absorption capacity. Further, variations in binding/absorption capacity may be observed for one or more specific compounds or elements.

There is a need in the art for novel methods of producing useable products such as activated carbon from corn derivatives and from waste by-product streams such as corn fiber and other corn derivatives.

It is an object of the present invention to overcome disadvantages of the prior art.

The above object is met by a combination of the features of the main claims. The sub claims disclose further advantageous embodiments of the invention.

SUMMARY OF THE INVENTION

The invention relates to methods of producing activated carbon and to products produced according to the method. More specifically, the present invention relates to a method of producing activated carbon from corn, corn fiber, corn derivatives and corn fiber derivatives and to products produced according to the method.

According to the present invention there is provided a method of producing activated corn carbon comprising the steps of a) pyrolysing corn derivatives to produce char and b) activating char to produce activated corn carbon.

The method of the present invention as defined above may comprise the steps of

- ○ a) pyrolysing corn derivatives at a temperature of between about 460° C. and about 560° C. for a duration of about 0.03 to about 2 seconds to produce char, and;
- b) activating the char using steam at a temperature of between about 500° C. to about 1000° C. and a steam to carbon ratio of about 0.4:1 to about 7:1 for a duration of between about 10 to about 90 minutes, to produce activated corn carbon.

In an embodiment of the present invention which is not to be considered limiting, the pyrolysis is performed for a duration of about 0.7 seconds, and the steam is at a temperature of about 800° C. to about 1000° C. Preferably, the steam to carbon ratio is about 0.4:1 to about 1.7:1 and the duration of activating is between about 30 to about 90 minutes.

Also provided by the present invention as defined above, the corn derivatives may comprise corn kernels, off grade corn kernels, corn cobs, corn fiber, corn hulls, corn stover, corn steep liquor, gluten, starch or any combination thereof. For example, but not to be considered limiting, the corn derivative may comprise a dried mixture of corn steep liquor and corn fiber produced during, but not limited to, the wet milling of corn. However, any corn product whether natural or processed may be employed in the method of the present invention.

Also provided by the present invention is a method of producing activated carbon comprising the steps of

- ○ a) pyrolysing corn derivatives at a temperature of between about 350° C. and about 560° C. for a duration of about 0.3 seconds to about 2 minutes to produce char, and;
- b) activating the char using steam at a temperature of between about 500° C. to about 1000° C. and a steam to carbon ratio of about 0.4:1 to about 7:1 for a duration of between about 10 to about 90 minutes, to produce activated carbon. The pyrolysis process employed in such a method may be considered a slow pyrolysis process, and such processes are meant to be encompassed in the method of the present invention.

Further, according to the method of the present invention as defined above, the char, activated corn carbon, or both may be optionally acid washed in a solution comprising hydrochloric, sulfuric, nitric, acetic, formic or

pyroligneous acid. Preferably, the acidic solution comprises between about 0.2 to about 5% (v/v) acid. Following acid washing the char or activated carbon or both may be subjected to a dewetting process, such as, but not limited to centrifugation, vacuum drum, filtering or a combination thereof. Further, the char, activated corn carbon or both may be rinsed with water.

Also provided by the present invention is an activated carbon produced according to the method as defined above. The activated carbon may comprise one or more of the following characteristics:

- ○ (a) an iodine number between about 200 and about 1200, preferably about 600 and about 1200, more preferably about 800 and about 1200 and;
- (b) a BET number between about 200 and about 1200, preferably about 600 and about 1200, more preferably about 800 and about 1200.

Also provided by the present invention is a method of removing one or more impurities from a mixture comprising the steps of:

- ○ a) contacting the mixture with activated corn carbon produced according to the method as defined above to produce a partially purified mixture, and;
- b) isolating the partially purified mixture from the one or more impurities.

The mixture may be, but is not limited to a solution or a gas mixture, and the one or more impurities may comprise one or more proteins, color pigments, small molecules, minerals, or a combination thereof. The small molecules may comprise, but are not limited to HMF, furfural or a combination thereof. Further, the minerals may comprise, but are not limited to calcium, magnesium, sodium, potassium, iron, copper, silicon, manganese, zinc, phosphorus, sulfur, chlorine or a combination thereof.

The present invention also provides a method as defined above which is part of a process such as, but not limited to, water purification process, ground water remediation process, air purification process, sugar and syrup decolorization process, waste water purification process, air pollution control process, or combination thereof.

Also provided by the present invention, the method as defined above may further comprise a pelletization step wherein the char or activated corn carbon is mixed with a binder such as, but not limited to starch, molasses, coal tar, natural resin, wood-based natural resin, corn based natural resin or a combination thereof.

This summary does not necessarily describe all necessary features of the invention but that the invention may also reside in a sub-combination of the described features.

BRIEF DESCRIPTION OF THE

DRAWINGS

These and other features of the invention will become more apparent from the following description in which reference is made to the appended drawings wherein:

FIG. 1A shows a flow diagram of a typical corn wet milling process.

FIG. 1B shows a flow diagram for the isolation of corn fiber and other corn components from a wet milling process.

DESCRIPTION OF PREFERRED EMBODIMENT

The invention relates to methods of producing activated carbon and to products produced according to the method. More specifically, the present invention relates to a method of producing activated carbon from corn, corn fiber, corn derivatives and corn fiber derivatives and to products produced according to the method.

According to the present invention, there is provided a method of producing activated carbon from corn derivatives. The method comprises the steps of a) pyrolysing corn derivatives to produce char and b) activating char to produce activated corn carbon. Other processing steps may also be present before, or after the steps of pyrolysing, activating or both. For example, but not wishing to be limiting, the char may be acid-washed after the step of pyrolysing and prior to activation, or the activated corn carbon may be acid-washed after the step of activating. Further, both the char and the activated corn carbon may be acid washed in the method of the present invention.

By the term "corn derivative" it is meant any product derived from corn, for example, but not limited to corn kernels, off grade corn kernels, corn cobs, corn fiber, corn hulls, corn stover, corn steep liquor, gluten, starch or any combination thereof. Further, corn derivative is meant to comprise products derived from corn in their natural state as well as products that may be partially or wholly processed, for example, but not limited to corn products produced during the wet milling of corn as described in Corn Starch 9th Edition Copyright 1994 Corn Refiners Association, Inc and Corn Wet Milled Feed Products, 3rd Edition Copyright 1989, Corn Refiners Association, Inc., which are herein incorporated by reference. An example, not meant to be limiting, of a corn wet milling process is shown in FIG. 1A. Corn derivatives that are produced during wet milling may be processed and isolated as shown in FIG. 1B (from Corn Chemistry and Technology by Stanley A. Watson and Paul Ramstad, published by the American Association of Cereal Chemists Inc, which is herein incorporated by reference). However, these figures are not meant to limit the invention as described herein in any manner as a variety of methods of obtaining corn derivatives are known in the art and these methods are fully contemplated by the present invention. In a nonlimiting embodiment of the

present invention, corn derivatives such as corn starch may be used independently or with filler. In an alternate embodiment which is not meant to be considered limiting, corn derivatives may comprise a dried mixture of corn steep liquor and corn fiber produced during the wet milling of corn. In such a manner, the present invention may be employed to recycle waste products produced from a process, such as, but not limited to a wet milling process.

The corn derivatives that are employed in the method of the present invention preferably comprise a moisture content of between about 0.4 to 10 wt %, more preferably between about 4 to 10 wt %, still more preferably about 5 to 7 wt %. Methods of determining the moisture content of such products are well known in the art and may be easily practiced by a person of skill in the art. Further, a person of skill in the art will recognize that corn derivatives comprising a moisture content above a preferred range may be dried using conventional methods known in the art to reduce the moisture content of the derivatives. Also, the corn derivatives may further comprise additional characteristics, for example, but not limited to one or more of the characteristics listed in Example 1, Table 5. However, the method of the present invention also contemplates using corn derivatives with characteristics that are different from any one or all of the characteristics shown in Example 1, Table 5.

The corn derivatives may be pyrolysed using any pyrolysis process known in the art. Without wishing to be limiting, an example of a pyrolysis process that may be employed by the method of the present invention is described in U.S. Pat. No. 5,792,340 which refers to rapid thermal processing of feedstocks. Alternatively, slow pyrolysis may be employed in the method of the present invention, for example, but not limited to the rotary kiln method of Calciner, which is herein incorporated by reference. In an embodiment of the present invention, the corn derivative is pyrolysed at a temperature of between about 460° C. and about 560° C. for a duration of about 0.03 to about 2 seconds, preferably about 0.7 seconds. Further, the pyrolysis process may be performed in any reactor, for example, but not limited to a sand transport reactor or a fluidized bed reactor as described in U.S. Pat. Nos. 5,792,340; 5,853,548; and 5,961,786 which are herein incorporated by reference. The solid char which is produced by the pyrolysis of corn derivatives may be activated to produce activated corn carbon, while the liquid product produced by pyrolysis may be used as a bio-oil or pitch for a variety of purposes including, but not limited to heating oil, diesel oil, or natural resin. Further, the char may be mixed with a natural resin binder to enable pelletization of the activated corn carbon. In an alternate embodiment, the solid char may be used as a fuel source.

The process disclosed in U.S. Pat. No. 5,792,340 (which is herein incorporated by reference) involves fast thermal processing (such as fast pyrolysis, rapid cracking) of carbonaceous materials (feedstock) using rapid mixing and heat transfer. The heat is transferred to the feedstock from hot inorganic particulate solids which are accelerated and then injected into the reactor through one or several streams, and impinge on one or several feedstock streams. The mixing section therefore combines the hot inorganic particulate solids and carbonaceous feedstock in a dense turbulent central stream in the mixing zone. Solids are accelerated at the

base of and throughout the mixing zone to enhance turbulence and mixing. A distinct, turbulent, mixing zone achieves extremely rapid, effective mixing of an inorganic particulate feedstock with a solid inorganic particulate heat carrier and a non-oxidative transport gas. Direct turbulent contact between the solid heat carrier and the feedstock provides very high heat transfer rates and effective particle ablation which are required for depolymerization and devolatilization reactions that provide maximum total liquid yields.

Without wishing to be limiting in any manner, rapid thermal processing involves:

- - a) introducing a primary stream of carbonaceous material and a secondary stream of upwardly flowing inorganic particulate heat supplying material into a mixing section in the relative absence of oxygen, the ratio of the mass of inorganic heat supplying material: mass of carbonaceous feedstock from about 12:1 to about 200:1;
 - b) maintaining the stream of carbonaceous material in contact with the secondary stream of heat supplying material through the reactor section to cause transformation of the carbonaceous material to a product stream;
 - c) separating the product stream from the heat supplying material by separation means at the exit of the reactor section such that the average residence time of contact between the carbonaceous material and the heat supply material is less than 2.0 seconds and the temperature of the products is reduced after exiting from the reactor section to less than 300° C. in less than 0.1 seconds; and
 - d) recycling the heat supplying material to the mixing section.

The inorganic particulate heat supplying material may be sand, sand and catalytic solids, alumina-silica catalyst or other inorganic catalyst; the ratio of the mass of inorganic heat supplying material: mass of carbonaceous feedstock is between about 12:1 and about 200:1, the heating rate of the carbonaceous material in the mixing section and reactor section is greater than 1000° C. per second; the average residence time of the carbonaceous material and the primary products in the mixing section and reactor section is between 0.03 and 1.8 seconds, the temperature in the reaction section is between 350° C. and 1000° C., the rate of carbonaceous material reaction (biomass throughput) is greater than 800 lb/hr sq. ft. of reactor cross-section, the product stream liquid yield from wood or wood-derived biomass is greater than 65 wt %. Other rapid thermal processes as described within the '340 patent may also be employed in the pyrolysis step of the present invention. Further, slow pyrolysis processes may also be employed in the method of the present invention.

Activation of the corn char may be performed by any activation process known in the art, for example, but not limited to, as described in WO 01/49604, WO 00/00429, U.S. Pat. Nos. 6,251,882 and 6,030,922, which are herein incorporated by reference. In an embodiment of the present invention, the corn char is activated by steam at a temperature between about 500° C. and about 1000° C., preferably about 800° C. and about 950°

C. using a steam:carbon ratio of about 0.4:1 to about 5:1, preferably about 0.4:1 to about 1.7:1 for a duration of about 10 to about 90 minutes, preferably about 30 to about 90 minutes. Other conditions may include activation at temperatures between about 500° C. to about 1000° C. or between about 800° C. to about 1000° C. The product produced by the activation of the char is activated corn carbon.

The char produced from pyrolysis of corn derivatives may be optionally acid-washed after pyrolysis and before activation in an acidic solution such as, but not limited to hydrochloric, sulfuric, nitric acid, acetic, formic or pyroligneous acid solution. Similarly, the activated corn carbon may be optionally acid-washed in the same manner. In an embodiment of the present invention, which is not meant to be limiting, the char produced via pyrolysis, or the corn carbon produced by activation may be acid washed while it is at a temperature in the range of about 100 to 200° C. In an alternate embodiment, the char, corn carbon or both may washed at room temperature. The acidic solution may comprise between about 0.2% (v/v) to about 5% (v/v) acid in water. In an embodiment of the present invention, the acidic solution comprises between about 1% to about 5% (v/v) HCl or other acid in water. However, acidic solutions outside this range are also contemplated by the present invention. Preferably, the water is substantially pure, that is, it contains low levels of impurities. Examples of such water include distilled, deionized or both distilled and deionized water.

After the char or activated corn carbon is acid-washed, it is dewetted by any process that is known in the art, for example, but not limited to filtering, vacuum drum, centrifugation or the like. Without wishing to be bound by theory, acid-washing of the char, activated corn carbon or both may reduce or remove undesired inorganic components. Further acid-washing may adjust the pH of the char, activated corn carbon or both.

Activated corn carbon samples produced according to the method of the present invention were tested to determine their iodine number and for their ability to remove protein, colour and HMF from a variety of test solutions. The results of the tests are shown in Tables 1, 2, and 3 below.

TABLE 1
Protein Removal by Activated Corn
Carbon Produced
According to the Method of the
Present Invention

	Protein Removal Sample 1 (+1% HCL acid wash) Iodine number 722	Protein Removal Sample 2 (+5% HCL acid wash) Iodine number 743
Treatment Level ¹	% Removal	% Removal
0.00%	—	—

0.10%	11	12
0.25%	18	17
0.5%	24	23
1.00%	27	25
1.50%	29	27

Table Footnote:

¹ treatment levels refer to the amount of carbon used per syrup. For example, a treatment level of 1% employs 1% activated corn carbon to 99% syrup.

TABLE 2

Color Removal by Activated Corn Carbon Produced According to the Method of the Present Invention

Treatment Level	Color Removal (+1% HCL acid wash)	Color Removal Sample 1 (+5% HCL acid wash)	Color Removal	
			Sample 1 (+5% Sulfuric acid wash)	Color Removal Virgin Sample
	Iodine number		1000	1000
	% Removal	% Removal	% Removal	% Removal
0.00%	—	—	—	—
0.10%	34	21	48	55
0.25%	44	27	75	80
0.50%	52	44	87	89
1.00%	64	54	92	94
1.50%	67	57	93	97
pH ¹	4.2	3.9	—	—

Table Footnote:

¹ pH refers to the pH of the syrup after treatment

TABLE 3

HMF Removal by Activated Corn Carbon Produced According to the Method of the Present Invention

Treatment level	HMF Removal Sample 1 (+1% HCL acid wash) % Removal	HMF Removal Sample 2 (+5% HCl acid wash) % Removal
0.00%	—	—
0.10%	41	35
0.25%	78	67
0.5%	87	82
1.00%	93	92
1.50%	94	99

As indicated by the results shown in Tables 1, 2 and 3, activated corn carbon produced according to the method of the present invention may be characterized by an iodine number between about 200 and about 1200, preferably about 800 and 1200, more preferably about 900 and 1200. Further, in two of the samples, the pH of the syrup following treatment is between about 3.9 and 4.2. Also, as shown by the table listing results regarding protein removal, the activated corn carbon is capable of removing between about 10% and about 30% of proteins for treatment conditions of between 0.10% and 1.50% as employed herein. Thus, the activated corn carbon samples of the present invention may be used to remove protein from a variety of solutions.

The results listed in Tables 2 and 3 further indicate that the activated corn carbon samples of the present invention may be employed to remove color and/or small molecules such as HMF and the like from solutions. Thus, the activated corn carbon produced by the method of the present invention may be employed to improve syrup color and reduce or remove undesirable components, such as protein, HMF and small molecules from solution.

Samples of activated corn carbon produced according to the method of the present invention were compared to other activated carbon samples known in the art. Referring now to Table 4, there is shown results of tests comparing the activated carbon sample produced according to the method of the present invention and CarboChem DC 50 (GAC) and Norit (PAC) activated carbons known in the art.

TABLE 4

Comparison of Activated
Corn Carbon (ACC)
produced
according to the method of
the present invention versus
powdered and granular
activated carbons known in
the art.

Impurity	CarboChem	ACC (1%)	ACC (5%)
----------	-----------	-------------	-------------

Measured	DC (GAC)	Norit (PAC)	HCl ¹	HCl ¹
Color Abs. (415 nm)	0.113	0.04	0.296	0.217
HMF (ppm)	1.09	0.35	0.19	0.17
Furfural(ppm)	<0.05	<0.05	<0.02	<0.02
Protein (ppm)	150	138	109	106
Sodium	308.96	296.1	234.07	235.01
Copper	0.04	0.05	0.03	0.03
Silicon	12.52	12.64	9.56	9.4
Silicon-total	14.82	11.93	10.7	10.8
Zinc	0.52	0.58	0.47	0.64
Phosphorus	26.28	26.9	23.41	21.08
Sulfur	158.4	135.88	101.89	101.22

Table footnote:

Protocols employed 1% carbon use to 99% syrup. The lower the value reported, the more efficient the removal.

¹ Indicates that the samples tested were acid washed following pyrolysis as described in the Examples. Color was measured by BRA (Corn Refiners Association) approved spectrophotometer at 450 mu wavelength. HMF and furfural were measured by HPLC method. Protein was measured by Antek combustion method. Metals were measured by ICP for metals method.

As shown by the results of Table 4, the corn carbon samples produced according to the method of the present invention were comparable or outperformed powdered and granular activated carbon samples known in the art, with respect to the removal of specific impurities. Without wishing to be limiting in any manner, the activated carbon product of the present invention exhibited increased HMF removal, protein removal and mineral removal.

The present invention also contemplates activated corn carbon produced using rapid thermal processing or slow pyrolysis, wherein the activated corn carbon exhibits characteristics as defined above. The present invention also provides activated corn carbon samples that are characterized as having an adsorption value (iodine number) of between about 200 and about 1200 mg/g, preferably about 600 to about 1200 mg/g, more preferably about 800 to about 1200 mg/g and a pH value of about 4.5 to about 5.5. Further, the activated corn carbon may be characterized as having a BET number between about 200 to about 1200, preferably about 600 to about 1200, more preferably about 800 to about 1200. The BET number reflects the extent of the pore surface area within the matrix of an activated carbon and may be employed as a preliminary indicator of the activity level, based on the principle that the greater the surface area, the higher the number of absorptive sites available. Methods for calculating the BET number are well known in the art, and can easily be determined by a person of skill in the art.

The activated corn carbon that is produced in accordance with the method of the present invention may be processed into granular, powdered or pelleted formulations. For example, but not to be limiting in any manner, the activated carbon may be mixed with a resin or binder, such as, but not limited to a starch, molasses, or wood based natural resin as is known in the art, or corn-based natural resin produced by the pyrolysis processes as described herein. Such mixtures may permit pelletization of activated corn carbon of the present invention.

Without wishing to be limiting, the activated corn carbon of the present invention may be employed in the filtration of liquids or gases. As disclosed herein, the activated corn carbon removes impurities, such as, but not limited to proteins, color pigments, small molecules such as HMF, furfural and the like, and minerals, such as but not limited to calcium, magnesium, sodium, potassium, iron, copper, silicon, manganese, zinc, phosphorus, sulfur, chlorine, etc. Specifically, but not to be considered limiting, the activated corn carbon maybe used for sugar and syrup decolorization, water purification, ground remediation, waste water purification, air purification, air pollution control, gas and vapor adsorption or any combination thereof. Further, the activated carbon produced according to the present invention may be employed in other processes known in the art.

The following description is of a preferred embodiment by way of example only and without limitation to the combination of features necessary for carrying the invention into effect.

The above description is not intended to limit the claimed invention in any manner. Furthermore, the discussed combination of features might not be absolutely necessary for the inventive solution.

The present invention will be further illustrated in the following examples. However, it is to be understood that these examples are for illustrative purposes only, and should not be used to limit the scope of the present invention in any manner.

EXAMPLES

Example 1

Characteristics of Corn Derivatives Employed in Pyrolysis

The corn fiber and corn gluten feed (examples of corn derivatives) used for pyrolysis are dried to comprise about 5% to about 7% moisture by weight. Analysis of the corn fiber and corn gluten feed indicated characteristics as shown in Table 5.

TABLE 5
Representative
Characteristics of Corn
Fiber and
Corn Gluten Feed
Determined Prior to
Pyrolysis

Characteristic	Value
Bulk Density 25° C. (kg/m ³) ¹	about 100–400
Moisture Content (wt %) ²	about 0.4–7.1
Ash Content (wt %) ³	about 0.5–0.6
Lignin (wt %) ⁴	about 2.7
Cellulose (wt %) ⁵	about 35.8
Hemicellulose (wt %) ⁵	about 35.9
Wood Extractives (wt %) ⁶	about 3.4
Carbohydrate (wt %) ⁵	about 71.7
Carbon (wt %) ⁷	about 45.45
Hydrogen (wt %) ⁷	about 6.48
Nitrogen (wt %) ⁷	about 1.54
Sulfur (wt %) ⁸	about 0.2
U.S. Sieve # +1/4–14 (wt %) ⁹	about 0–83
U.S. Sieve # +14–35 (wt %) ⁹	about 16–100
U.S. Sieve # +35–50 (wt %) ⁹	about 0–29

Table Footnotes:

¹ American Society for Tests and Materials (ASTM D1298-85);

² ASTM D3173;

³ ASTM D3174;

⁴ Pulp and Paper Technical Association of Canada (PAPTAC) J8 J9;

⁵ Technical Association of the Pulp and Paper Industry (TAPPI) T 249;

⁶ TAPPI 264;

⁷ ASTM D 5291;

⁸ ASTM 5142;

⁹ ASTM 5709.

Example 2

Parameters for Pyrolysis of Corn Derivatives

Pyrolysis of corn derivatives may be performed in a sand bed reactor or a fluidized bed reactor, for example, but not limited to as described in U.S. Pat. Nos. 5,792,271; 5,961,786; and 5,853,548; which are herein incorporated by reference. Pyrolysis was performed at a temperature of between about 460° C. to about 560° C. for a duration of about 700 milliseconds and a condensing temperature of between about 46° C. and 100° C., preferably about 50° C. and 100° C. The pyrolysis process yields about 73% liquid and between about 7% and about 14% char by weight.

Corn derivatives pyrolysed according to the processing conditions described above yielded about 73 wt %, but may yield in excess of 75% in industrial processes. The non-optimized maximum concentration of the 7 most predominant chemical compounds in the liquid product was about 33 wt %. Without wishing to be bound by theory, this is equivalent to a yield of about 24% of the pre-pyrolyzed corn derivatives if a liquid yield of about 73% is assumed. The yield of hydroxyacetaldehyde (HA), a chemical indicator, was about 7.5 wt % of the corn derivatives (about 10 wt % of the liquid) and the yield of levoglucosan was about 6 wt % (7.7 wt % of the liquid).

Products produced by Pyrolysis Conditions as defined above are shown in Table 6.

TABLE 6

Product Yields
Produced from
Pyrolysis Operating
Conditions

						Total recov- ery	Total recov- ery
Liquid (as fed)	Liquid (maf)	Gas (as fed) ¹	Gas (maf) ²	Char (as fed)	Char (maf)	(as fed)	(maf)
70.8–	69.3–	10–	10.5–	7.2–	7.2–	93.4–	93.1–

Table footnote

¹ As fed refers to the condition of the corn derivatives fed into the rapid thermal processing reactor system and corresponds to about 5–7 wt % water and about 0.75 to 1.0 wt % ash.

² maf refers to moisture/ash free wherein the moisture and ash are mathematically removed from the feedstock to determine the effect of only the organic content of the feed.

Char yields were in the range of about 7 to about 13 wt % of the feed material. Further analysis of the char produced by pyrolysis indicated a heating value of between about 27 and about 28 MJ/kg. This suggests that the char may be used as a fuel or upgraded to activated carbon by activating the char.

Example 3

Activation of Char Produced from Pyrolysis

Char produced from the pyrolysis of corn derivatives was activated according to numerous process conditions as shown in Table 7.

TABLE 7

Activation
Conditions for the
Production of
Activated Carbon

Sample #	Char Feedstock*	Avg. reactor temperature (° C.)	Steam:Carbon Ratio	Residence Time (minutes)
18	a	880	1.7:1	90
19	a	804	0.4:1	30
20	a	822	0.4:1	30
21	a	807	0.4:1	60
22	a	839	0.4:1	60
23	b	802	0.7:1	60
24	b	845	0.6:1	60

* (a) refers to pyrolysed corn char that is subsequently activated; (b) refers to pyrolysed corn char that is treated by acid wash flotation as described in Example 4 and subsequently activated as described above.

Table 7 shows representative conditions employed to activate pyrolysed corn char. Table 7 is not meant to be limiting in any manner and variations

of the reactor temperature, steam:carbon ratio and residence time, alone or in any combination from the values listed are also meant to be encompassed by the present invention.

Example 4

Acid Wash Flotation of Corn Char

Char from pyrolysis of corn derivatives is obtained as described in Example 2. A known amount of char is combined with 1% or 5% (v/v) HCl in water in a 1:1 weight ratio, and mixed with a drill for between 2 to 3 minutes. The mixed char is allowed to settle overnight (about 16 hours) and subsequently filtered through a Whatman #40 filter paper and rinsed with about 500 ml of distilled water. The rinsed char is dried until the char exhibits a water content of less than about 5% by weight. The acid-washed char may be activated, for example, but not limited to, as outlined in Example 3.

All references cited above are herein incorporated by reference.

The present invention has been described with regard to preferred embodiments. However, it will be obvious to persons skilled in the art that a number of variations and modifications can be made without departing from the scope of the invention as described herein.

Greenhouse Gas

Get Greenhouse Gas info for free, from IndustryWeek
www.IndustryWeek.com

Anaerobic Digestion

We turn methane gas from organic waste into revenue for you
www.biogas.co.uk

Membrane Technology

Membrane Technology, Evaporation Systems

Wastewater Treatment

Industrial Effluents Municipal Wastewaters
www.veoliawaterst.com

Greenhouse Gas

Get Greenhouse Gas info for free, from IndustryWeek
www.IndustryWeek.com

Membrane China

Thousands of Prequalified Suppliers Trade Leads, Products & Companies.
www.Alibaba.com

Anaerobic Digestion

We turn methane gas from organic waste into revenue for you
www.biogas.co.uk

Pyrolysis Waste Solutions

Ultimate Resource Recovery Systems Solutions for Any Waste Problems
www.kleanindustries.com

Heat Treatment Process

ISO9001:2000 authorized enterprise Fast service & your choice. Check!
www.ndly.com.cn

Carbon Fiber Lines

Harper offers complete carbon fiber systems to produce carbon fiber
www.harperintl.com

Biodiesel Process Equip

Water Free processing equipment 3 to 60 million gallons-Plant Tours
www.greenlineindustries.com

[<- Previous Patent \(Purification catalys...\)](#) | [Next Patent \(Aqueous compositions...\)->](#)

of the reactor temperature, steam:carbon ratio and residence time, alone or in any combination from the values listed are also meant to be encompassed by the present invention.

Example 4

Acid Wash Flotation of Corn Char

Char from pyrolysis of corn derivatives is obtained as described in Example 2. A known amount of char is combined with 1% or 5% (v/v) HCl in water in a 1:1 weight ratio, and mixed with a drill for between 2 to 3 minutes. The mixed char is allowed to settle overnight (about 16 hours) and subsequently filtered through a Whatman #40 filter paper and rinsed with about 500 ml of distilled water. The rinsed char is dried until the char exhibits a water content of less than about 5% by weight. The acid-washed char may be activated, for example, but not limited to, as outlined in Example 3.

All references cited above are herein incorporated by reference.

The present invention has been described with regard to preferred embodiments. However, it will be obvious to persons skilled in the art that a number of variations and modifications can be made without departing from the scope of the invention as described herein.

Greenhouse Gas

Get Greenhouse Gas info for free, from IndustryWeek
www.IndustryWeek.com

Anaerobic Digestion

We turn methane gas from organic waste into revenue for you
www.biogas.co.uk

Membrane Technology

Membrane Technology Evaporation Systems

Wastewater Treatment

Industrial Effluents Municipal Wastewaters
www.veoliawaterst.com

Greenhouse Gas

Get Greenhouse Gas info for free, from IndustryWeek
www.IndustryWeek.com

Membrane China

Thousands of Prequalified Suppliers Trade Leads, Products & Companies.
www.Alibaba.com

Anaerobic Digestion

We turn methane gas from organic waste into revenue for you
www.biogas.co.uk

Pyrolysis Waste Solutions

Ultimate Resource Recovery Systems Solutions for Any Waste Problems
www.kleanindustries.com

Heat Treatment Process

ISO9001:2000 authorized enterprise Fast service & your choice. Check!
www.ndly.com.cn

Carbon Fiber Lines

Harper offers complete carbon fiber systems to produce carbon fiber
www.harperintl.com

Biodiesel Process Equip

Water Free processing equipment 3 to 60 million gallons-Plant Tours
www.greenlineindustries.com

[<- Previous Patent \(Purification catalys...\)](#) | [Next Patent \(Aqueous compositions...\)->](#)