

raf

TK7868.P6.Z82 2010.



0000073562

Design of portable power supply from wave energy / Zubir  
Mahmod.

**DESIGN OF PORTABLE POWER SUPPLY  
FROM WAVE ENERGY**

**Zubir bin Mahmod**

**Bachelor of Electrical Engineering  
(Industrial Power)**

**May 2010**

“ I hereby declare that I have read through this report entitle “Portable Power Supply from Wave Energy” and found that it has comply the partial fulfillment for awarding the degree of Bachelor of Electrical Engineering (Industrial Power)”

Signature :  .....

Supervisor's Name : Mr. Mohd Farriz Bin Hj Md Basar

Date : 07<sup>th</sup> May 2010

**PORTABLE POWER SUPPLY FROM WAVE ENERGY**

**ZUBIR BIN MAHMUD**

**A report submitted in partial fulfillment of the requirements for the degree of  
Electrical Engineering (Industrial Power)**

**Faculty of Electrical Engineering  
UNIVERSITI TEKNIKAL MALAYSIA MELAKA**

**2010**

I declare that this report entitle “Portable Power Supply from Wave Energy” is the result of my own research except as cited in the references. The report has not been accepted for any degree and is not concurrently submitted in candidature of any other degree.

Signature :  .....

Name : Zubir Bin Mahmud

Date : 07<sup>th</sup> May 2010

## ACKNOWLEDGEMENT

Assalamualaikum warahmatullahi wabarakatuh

Alhamdulillah. I thank to God for allowing me to complete my Final Year Project without any difficulty. Here I wish to say deepest gratitude to my supervisor namely Mr. Mohd Farriz Bin Hj Md Basar because given me an opportunity to done this project namely “Portable Power Supply from Wave Energy”. He always helps and supports me in project deliverables to give high quality especially in learn an information about this project. Besides, he has always motivated and encouraged me whenever I encountered any problem. My supervisor has a lot of assistance in guiding and coaching me consistently in the whole period of this project.

Million of thanks to my parents. They have always support and motivated me to complete this project.

I also would like to thank my lovely friends who involved in this project namely Abdul Razak, Mohd Iskandar, Hanafiah and the others not mentioned herein, but in one way or another, might have directly or indirectly contributed to the successful completion of my Final Year Project. All of their good deeds will always be remembered throughout my life.

Thanks to all of you.

## ABSTRACT

Non-renewable energy such as petroleum, coal, gas and nuclear cannot be restored once it has been used. Many countries in the world are heavily dependent on the non-renewable energy and polluting sources to generate electricity. This would cause the greenhouse gas emissions and would have adverse effects on the country due to climate changes. Generally, approximately 75% of earth is covered by the ocean and for that reason, many investors starting to develop a technology for harnessing the ocean wave. Wave energy is a form of renewable energy available on the earth where converting the ocean wave energy into electricity. In this project, it will study and develop the "Portable Power Supply from Wave Energy". Therefore, it will employ a basic concept of Faraday's Law. Wave energy is use as a prime mover for this project where it helps the solenoid to move right and left of permanent magnet to generate electricity. The magnetic field of magnets is cut by the solenoid and current is induced in the coil. The amount of induces current is depends on the number of wire turns, the number and the strength of magnet and the relative movement of magnet. Thus, this project is attempted to use a permanent magnet (Neodymium Iron Boron) and solenoid with 4000 turns of wire turns. The movement of wave will cause solenoid move to the right and move to the left of permanent magnet and cuts the magnetic fields and simultaneously produce alternating current (AC) voltage and then convert to direct current (DC) by using voltage multiplier. It is therefore, this project is very useful to supply electricity for small load such as LED lighting for outdoor activities likes camping and picnic.

## ABSTRAK

Tenaga tidak boleh diperbaharui seperti petroleum, arang batu, gas dan nuklear tidak boleh dikitar semula setelah digunakan. Kebanyakan negara bergantung kepada tenaga tidak boleh diperbaharui dan sumber-sumber yang tercemar untuk menjana bekalan elektrik. Ini akan menyebabkan pengeluaran gas rumah hijau dan kesan buruk kepada sesebuah negara itu kerana perubahan iklim. Umumnya, bumi diliputi hampir 75% oleh lautan dan oleh sebab itu, ramai pelabur tertarik untuk membuat kajian dan membangunkan teknologi yang boleh memanfaatkan sumber gelombang lautan. Tenaga gelombang lautan adalah satu jenis tenaga yang boleh diperbaharui di mana ia boleh ditukarkan daripada tenaga gelombang lautan kepada tenaga elektrik. Projek ini bertujuan mengkaji dan merekabentuk suatu model yang dipanggil “Bekalan Kuasa Mudah Alih Daripada Tenaga Gelombang”. Oleh itu, projek ini menggunakan konsep asas *Faraday Law's*. Tenaga gelombang lautan digunakan sebagai penggerak utama untuk projek ini di mana ia membantu gegelung untuk bergerak ke kanan dan bergerak ke kiri magnet untuk menjana bekalan elektrik. Medan magnet yang terdapat pada magnet akan dipotong oleh gegelung. Jumlah potongan medan magnet bergantung kepada jumlah pusingan gegelung, jumlah dan kekuatan magnet dan pergerakan relatif magnet. Oleh itu, projek ini akan menggunakan magnet kekal (*Neodymium Iron Boron*) dan gegelung dengan 4000 pusingan. Pergerakan gelombang lautan akan menyebabkan gegelung akan bergerak ke kanan dan bergerak ke kiri magnet, memotong medan magnet dan seterusnya akan menjana voltan ulang-alik dan akan ditukarkan kepada arus terus menggunakan pengali voltan. Oleh itu, projek ini amat berguna untuk membekalkan tenaga elektrik kepada muatan kecil seperti lampu LED untuk melakukan aktiviti luar seperti berkhemah dan berkelah.

## TABLE OF CONTENTS

CHAPTER	TITLE	PAGE
	<b>ACKNOWLEDGEMENT</b>	<b>iv</b>
	<b>ABSTRACT</b>	<b>v</b>
	<b>TABLE OF CONTENTS</b>	<b>vii</b>
	<b>LIST OF TABLES</b>	<b>ix</b>
	<b>LIST OF FIGURES</b>	<b>x</b>
	<b>LIST OF APPENDICS</b>	<b>xii</b>
<b>1</b>	<b>INTRODUCTION</b>	<b>1</b>
	1.1 Project Background	1
	1.2 Problem Statement	2
	1.3 Objective	3
	1.4 Scope of Project	3
<b>2</b>	<b>LITERATURE REVIEW</b>	<b>4</b>
	2.1 Ocean Wave Energy	4
	2.1.1 Ocean Wave Characteristic	5
	2.1.2 Ocean Wave Energy Technologies	7
	2.1.2.1 Terminator	9
	2.1.2.2 Attenuators	10
	2.1.2.3 Points Absorbed	11
	2.2 Magnet	12
	2.2.1 Characteristic of Permanent Magnet	14
	2.2.2 Selection of Permanent Magnet	15
	2.2.3 The Care of Permanent Magnet	16



<b>3</b>	<b>METHODOLOGY</b>	<b>21</b>
	3.1 Research Methodology and Experimental Work	21
	3.2 Full Scale Model	24
	3.3 Project Planning	25
<b>4</b>	<b>RESULTS</b>	<b>27</b>
	4.1 Preliminary Testing by Using 19 SWG Enamelled Copper Wire	27
	4.2 Preliminary Testing by Using 25 SWG Enamelled Copper Wire	32
	4.3 Voltage Multiplier	36
	4.4 Simulation	37
	4.5 Full Scale Model Testing	38
	4.6 Field Testing at Pantai Puteri, Melaka	40
<b>5</b>	<b>ANALYSIS AND DISCUSSION</b>	<b>43</b>
	5.1 Analysis	43
	5.2 Discussion	56
	5.3 Suggestion	56
<b>6</b>	<b>CONCLUSION</b>	<b>57</b>
	<b>REFERENCES</b>	<b>58</b>
	<b>APPENDIX A</b>	<b>59</b>
	<b>APPENDIX B</b>	<b>60</b>

## LIST OF TABLES

<b>TABLE</b>	<b>TITLE</b>	<b>PAGE</b>
2.1	Special Characteristics of Permanent Magnet	14
2.2	Comparison between Four Types of Permanent Magnet Material	16
3.1	Project Planning	26
4.1	Induced Voltage and Current during 100 Turns of 19 SWG Wire	29
4.2	Induced Voltage and Current during 200 Turns of 19 SWG Wire	29
4.3	Induced Voltage and Current during 300 Turns of 19 SWG Wire	29
4.4	Induced Voltage and Current during 400 Turns of 19 SWG Wire	30
4.5	Induced Voltage and Current during 500 Turns of 19 SWG Wire	30
4.6	Induced Voltage and Current during 600 Turns of 19 SWG Wire	30
4.7	Induced Voltage and Current during 700 Turns of 19 SWG Wire	31
4.8	Induced Voltage and Current during 800 Turns of 19 SWG Wire	31
4.9	Induced Voltage and Current during 900 Turns of 19 SWG Wire	31
4.10	Induced Voltage and Current during 1000 Turns of 19 SWG Wire	32
4.11	Induced Voltage and Current during 100 Turns of 25 SWG Wire	32
4.12	Induced Voltage and Current during 200 Turns of 25 SWG Wire	33
4.13	Induced Voltage and Current during 300 Turns of 25 SWG Wire	33
4.14	Induced Voltage and Current during 400 Turns of 25 SWG Wire	33
4.15	Induced Voltage and Current during 500 Turns of 25 SWG Wire	34
4.16	Induced Voltage and Current during 600 Turns of 25 SWG Wire	34
4.17	Induced Voltage and Current during 700 Turns of 25 SWG Wire	34
4.18	Induced Voltage and Current during 800 Turns of 25 SWG Wire	35
4.19	Induced Voltage and Current during 900 Turns of 25 SWG Wire	35
4.20	Induced Voltage and Current during 1000 Turns of 25 SWG Wire	35

## LIST OF FIGURES

FIGURE	TITLE	PAGE
2.1	Shape of Ocean Wave	4
2.2	Characteristic of Idealized Wave	6
2.3	Schematic Representation of Various Types Wave Energy Converter	7
2.4	Generator Assembly Sketch	8
2.5	Oscillating Water Column	9
2.6	Pelamis Wave Energy Converter	10
2.7	Aqua Buoy Point Absorber Wave Energy	11
2.8	Direction of Induced Current	13
2.9	Neodymium Iron Boron (NdFeB) Magnet	17
2.10	Samarium Cobalt (SmCo) Magnet	18
2.11	Alnico Magnet	19
2.12	Ceramic or Ferrite Magnet	20
3.1	Project Methodology	22
3.2	Full Scale Mode	24
4.1	Enamelled Copper Wire (19 SWG)	27
4.2	Neodymium Iron Boron Magnet	27
4.3	Preliminary Model Setup	28
4.4	Half Wave Rectifier	36
4.5	Full Wave Rectifier	36
4.6	Voltage Multiplier Circuit	37
4.7	Simulation Result	38
4.8	Actual Model Setup	39
4.9	Preliminary Testing	39
4.10	Full Scale Model Setup	41
4.11	Real testing on Ocean Wave	42
4.12	Real testing on Ocean Wave	42
5.1	Induced Voltage Obtained During 100 Turns of Wire without Load	44
5.2	Induced Current Obtained During 100 Turns of Wire without Load	45

5.3	Induced Voltage Obtained During 200 Turns of Wire without Load	45
5.4	Induced Current Obtained During 200 Turns of Wire without Load	46
5.5	Induced Voltage Obtained During 300 Turns of Wire without Load	46
5.6	Induced Current Obtained During 300 Turns of Wire without Load	47
5.7	Induced Voltage Obtained During 400 Turns of Wire without Load	47
5.8	Induced Current Obtained During 400 Turns of Wire without Load	48
5.9	Induced Voltage Obtained During 500 Turns of Wire without Load	48
5.10	Induced Current Obtained During 500 Turns of Wire without Load	49
5.11	Induced Voltage Obtained During 600 Turns of Wire without Load	49
5.12	Induced Current Obtained During 600 Turns of Wire without Load	50
5.13	Induced Voltage Obtained During 700 Turns of Wire without Load	50
5.14	Induced Current Obtained During 700 Turns of Wire without Load	51
5.15	Induced Voltage Obtained During 800 Turns of Wire without Load	51
5.16	Induced Current Obtained During 800 Turns of Wire without Load	52
5.17	Induced Voltage Obtained During 900 Turns of Wire without Load	52
5.18	Induced Current Obtained During 900 Turns of Wire without Load	53
5.19	Induced Voltage Obtained During 1000 Turns of Wire without Load	53
5.20	Induced Current Obtained During 1000 Turns of Wire without Load	54
5.21	Induced Voltage in Difference Number of Wire Turns without Load	55
5.22	Induced Current in Difference Number of Wire Turns without Load	55

**LIST OF APPENDICES**

<b>APPENDIX</b>	<b>TITLE</b>	<b>PAGE</b>
A	Copper Enamelled Wire	59
B	Magnetic Characteristic and Physical Properties of NdFeB	60

## CHAPTER 1

### INTRODUCTION

#### 1.1 Project Background

This project is all about the “Portable Power Supply from Wave Energy”. The term of “portable” meaning that the product of this project is easily to moveable anywhere because of the size is small. This portable power supply is able to produce electricity where it can be use for military purposes or for the outdoor activities such as picnic and camping.

There are two types of energy source in the world which non-renewable energy and renewable energy. Once a non-renewable energy source is used, it cannot be replace but renewable energy source is one that can be replacing and it is good for our environments. The term of “renewable” referred to its energy because it does not finish even though it is use regularly. This energy has a few advantages than non-renewable energy such as the energy is free because its form natural resources, it’s clean to the environment and cheaper. There are many types of renewable energy available on earth but the ocean wave is one which growing up recently according to the research and development to harnessing their energy.

This project intended to generate electricity by using wave energy with the aid of solenoid and permanent magnet. The literature review is cover about the permanent magnet, copper wire, ocean wave and previous study on ocean wave.

The preliminary model setup has been constructed to understand and verify the system principle which permanent magnet and solenoid can generate electricity. The basic idea to generate electricity is form Faraday’s Law where the magnetic fields of permanent magnet is cut by solenoid. A few shape of permanent magnet and various number of wire

turns are used in this testing. Some analysis and discussion need to be done after preliminary testing completed.

The full-scale model has been developing as a real model of a wave energy device. This model was tested in a real situation. So that, harvesting the ocean wave energy and convert it to the electricity power.

## **1.2 Problem Statement**

This project is constructing based on a few problem statement. Firstly, is about the non-renewable energy. Nowadays, power plants use sources such as diesel, coal and gas. Once these are burned to generate electricity, their energy is lost forever. It is thought that the current resources for oil and gas under the North Sea will last about another 20 years and the world resources will last for about 70 years. Even though the world has relatively larger reserve for coal but it is expected that the coal can be lasting only for the next century [9]. For that reason, developing an alternative energy is must for future demand.

Besides that, the oil price has increased up to \$100.00 per barrel and all countries anxious with this situation [10]. Therefore, to solve this oil prices crisis, the ocean wave is used as the alternative energy to generate electricity.

Next, the problem associated with fossil fuels uses are that the extraction of fossil fuel causes local environment problem including damage to land surface, noise, dust, acid rain and pollution [11]. In order to reduce this effect, the wave energy is harnessing to obtain a green energy for electricity.

An additional, the past research and product has a bulky size and apply on the open sea only. It is fixed design and unremoveable product. Therefore, to make the product more comfortable and convenient, this project has an advantages because of it size is small and allocate at the seaside.

The old design of the product is much expensive compare with the proposed one because it use a lot of materials and the materials is in biggest size which required high

cost to build it. Compare with the new one, it is cheaper because the material used is not much and more simply than the old one.

### **1.3 Objective**

The objectives of this project are:

1. To generate induced current with the aid of magnet and solenoid
2. To analyze the effect of magnet, solenoid and relative movement of magnet to the electrical characteristics
3. To develop a hardware for harnessing the wave energy.

### **1.4 Scope of Project**

In order to achieve the project objectives, the following scopes will be covered:

1. Studies the literature reviews about the magnet, copper wire, ocean wave and previous study on ocean wave.
2. Identifies the circuits and components and procurement of components and materials.
3. Conduct a preliminary testing by using various shapes of permanent magnet and number of wire turns to understand and verify the system principle.
4. Construct the full scale model by using wave energy to generate electricity.

Studying the literature reviews about the magnet, copper wire, ocean wave and previous study on ocean wave is a very fundamental in order to develop a full scale system for harnessing the wave energy. Next, circuits and components that are used need to be identified and then procurement of components and material should be done. In addition, the preliminary testing is constructed by using various shapes of permanent magnet and numbers of wire turns to understand and verify the system principle. Finally, the full scale model has been constructed and tested by using wave energy to generate electricity.



## CHAPTER 2

### LITERATURE REVIEW

#### 2.1 Ocean Wave Energy

Ocean has a sinusoidal waveform where the highest peak is called crest and lowest part is called troughs. The difference in height between peaks and troughs is known as height,  $H$  and the distance between successive peak (or troughs) of wave is known as a wavelength,  $\lambda$  [1]. The wave period  $T$  is the time interval between passage of successive crests at a stationary points. The shape of ocean wave is shown in Figure 2.1 below:

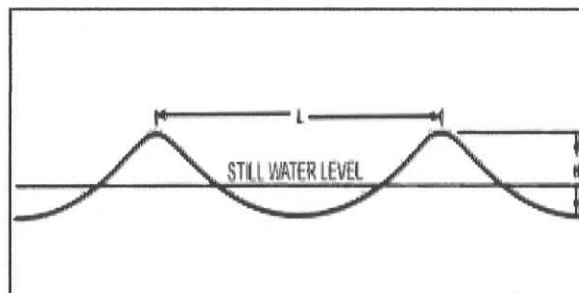

**Figure 2.1:** Shape of Ocean Wave

Waves are generated when wind passing over the sea. There is an energy transfer from the wind to the most of wave when the waves propagate slower than the wind speed. Waves growth happened when there are difference in both air pressure between the upwind and the lee side of a wave crest.

Wave height is depends on a few factor such as wind speed, time duration the wind has been blowing and water depth. Wave size is determined by wind speed and fetch and by the depth and topography of the seafloor. A given wind speed has a matching practical limit over which time or distance will not produce larger waves. This limit is called a “fully developed sea” [7].

There are three type of wind wave which is capillary waves or ripples, sea and swells. Ripples appear on smooth water when the wind blowing but it will die quickly if there is no wind. The irregular motions under sustained winds as called sea and they much longer than the ripples even after the wind is died. Swells are created when seas propagate away from their area of origin.

### 2.1.1 Ocean Wave Characteristic

The wave power is determined by wave speed, wavelength and water density. Usually, when the wave is larger we can say that the wave is more powerful than the smaller one.

As mention in previous section, we can suppose that the peaks and troughs of ocean wave move across the surface with the velocity,  $v$  and time in seconds is taken for successive peaks (or troughs) is known as the period,  $T$ . When the waves travel at velocity  $v$ , it will travel a distance that it's equal to its wavelength  $\lambda$  in a time equal to the wave period  $T$ . So, the velocity  $v$  is equal to the wavelength  $\lambda$  divided by the period of  $T$ . The mathematically equation can be express in Equation 2.1 below:

$$v = \frac{\lambda}{T} \quad (2.1)$$

In deep water waves, if the water is greater than the half of its wavelength, the velocity of ocean wave can be express in Equation 2.2:

$$v = \frac{gT}{2\pi} \quad (2.2)$$

The properties of the waves is increases by water depth when the water become shallower and when it reach shallow water, their properties are completely is taken by the water depth but for the intermediate depths the properties of the waves is influenced by both water depth  $d$  and water period  $T$ . When the waves approach the shore, the seabed starts to have an effect on their speed and this can be show if the water depth  $d$  is less than a quarter of the wavelength. The current velocity in this stage is shown in Equation 2.3 below:

$$v = \sqrt{gd} \quad (2.3)$$

The characteristic of an idealized wave is shown in Figure 2.2 below:

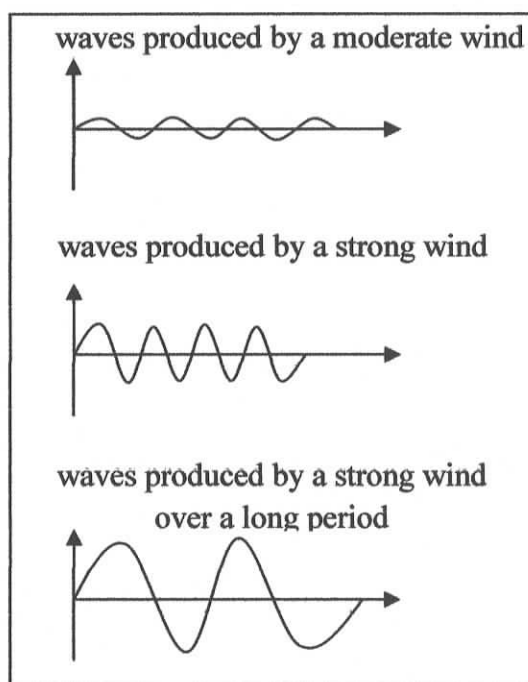

**Figure 2.2:** Characteristic of Idealized Wave

Wave energy is depends on wind speed, time duration of the wind blowing, the distance of open water that the wind has blown over and water depth. Wave power could be determined by wave height, wavelength and water density [2]. This mathematically could be described as in Equation 2.4 [3].

$$P = \frac{\rho g^2 T H^2}{32\pi} \text{ watt per meter} \quad (2.4)$$

where;

- $\rho$  : the density of seawater ( $\text{kg/m}^3$ )
- $g$  : acceleration due to gravity ( $\text{m/s}^2$ )
- $H$  : wave height (m)
- $T$  : period of wave (s)

The amount of energy available in a given wave can be expressed in terms of energy density or energy flux  $\bar{E}$  [2]. The SI unit is used and the energy density units is Joules per meter squared. The Equation 2.5 below has shown the equation of energy density or energy flux:

$$\bar{E} = \frac{\rho g \bar{H}^2}{8} \quad (2.5)$$

where;  $\rho$  : density of seawater ( $\text{kg/m}^3$ )  
 $g$  : acceleration due to gravity ( $\text{m/s}^2$ )  
 $H$  : wave height (m)

## 2.1.2 Ocean Wave Energy Technologies

In order to capture energy from sea waves, variety of technologies has been used to harnessing the wave energy to convert into useful electrical energy. However, each is in too early a stage of development to predict which technology or mix of technologies would be most prevalent in future commercialization [3].

Wave energy converter is devices that can be convert the wave energy to electrical energy which it is central, stable structure and have some active part which moves relative to it under the force of the waves. There are many different configuration of wave energy converter and a number of ways of classifying them have been proposed. One schematic representation of the various types wave energy converter is shown in Figure 2.3 below [1].

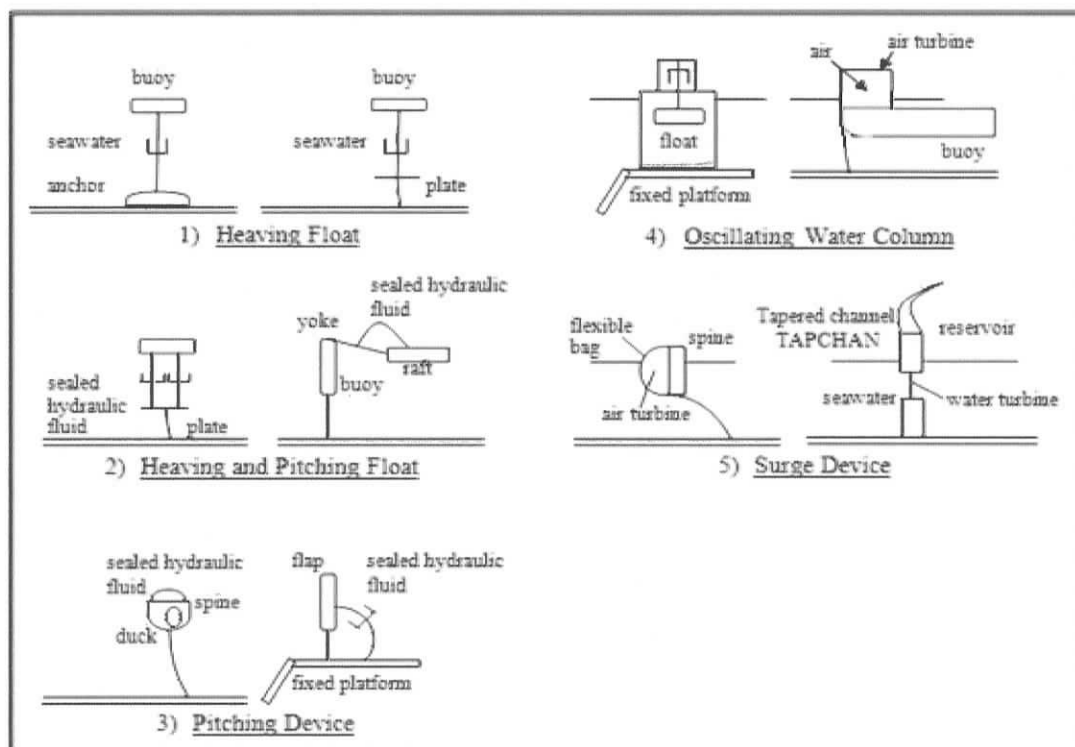

**Figure 2.3:** Schematic Representation of Various Types Wave Energy Converter

Wave energy converters can be classified in terms of their location [1]:

- a) Fixed to the seabed, generally in shallow water.
- b) Floating offshore in deep water or
- c) Tethered in intermediate depths

According to the paper “Numerical Modeling of the Electric Linear Generator Based on the Sea Wave Energy”, permanent magnet linear generator can be used as producing electrical energy based on clean resources, such as sea waves energy. These generators have special features in comparison with other types of electric generators. They take the advantage of renewable energy resources such as it's do not pollute the environment, have to be water-proofed, and can be built in a range of various powers without having geometrical dimensions limitations [4].

The operating principle of this project is simple where there is an armature with permanent magnet at the central of their designed. The armature will anchored to the sea floor, and the floater moves the permanent magnet relative to the fixed armature coils to induce voltage. In Figure 2.4 below, it show the sketch of the entire system. Part number 1 show the translating armature, part number 2 is a fixed armature with coils, part number 3 is a shaft, part number 4 is a fixing pillar, part number 5 is a buoys/floater, part number 6 is a rope and part number 7 is a spring.

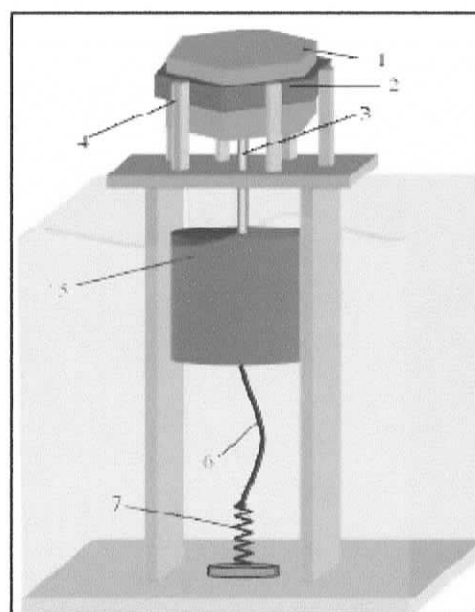
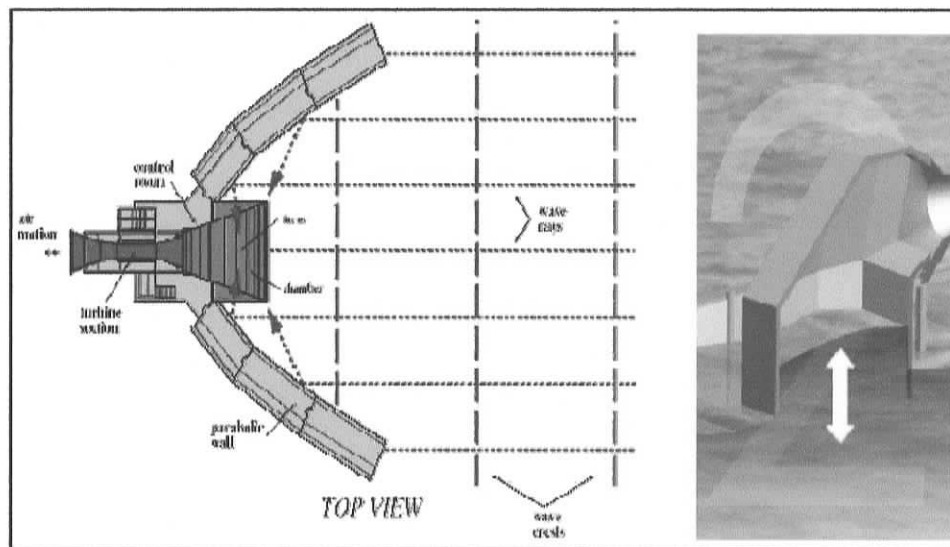

**Figure 2.4:** Generator Assembly Sketch

Otherwise, the wave energy converter can be divided into three categories based on their geometry and orientation such as terminator, attenuators and point absorbers.

### 2.1.2.1 Terminator

Terminator devices extend perpendicular to the direction of wave travel and capture or reflect the power of the wave. These devices are typically installed onshore or nearshore. However, floating versions have been designed for offshore applications. The oscillating water column (OWC) is an example form of terminator in which water enters through a subsurface opening into a chamber with air trapped above it. The wave action causes the captured water column to move up and down like a piston to force the air through an opening connected to a turbine. A full-scale, 500-kW, prototype OWC designed and built by Energetech in year 2006 shown in Figure 2.5 and it is undergoing testing offshore at Port Kembla in Australia, and a further project is under development for Rhode Island [3].



**Figure 2.5:** Oscillating Water Column [3]

In an Electric Power Research Institute (EPRI), a design, performance, and cost assessment was conducted for an Energetech commercial-scale OWC with a 1,000-kW rated capacity, sited 22 km from the California shore. With the wave conditions at this site (20 kW/m average annual), the estimated annual energy produced was 1,973 MWh/yr. For a scaled-up commercial system with multiple units producing 300,000 MWh/yr, the estimated cost of electricity would be on the order of \$0.10/kWh [3].

### 2.1.2.2 Attenuators

Attenuators are long multisegment floating structures oriented parallel to the direction of the wave travel. The differing heights of waves along the length of the device causes flexing where the segments connect, and this flexing is connected to hydraulic pumps or other converters [3]. The example of attenuators is Pelamis by Ocean Power Delivery, Ltd.

The Pelamis is a semi-submerged machine, articulated structure composed of cylindrical sections linked by hinged joints. The wave-induced motion of these joints is resisted by hydraulic rams, which pump high-pressure oil through hydraulic motors via smoothing accumulators. The Pelamis contains three Power Conversion Modules, each rated at 250kW (sea tested for 1000 hours in 2004).

The first stage, scheduled to be completed in 2006, consists of three Pelamis machines with a combined rating of 2.25 MW to be sited about 5 km off the coast of northern Portugal. An expansion to more than 20-MW capacity is being considered.

A Pelamis powered 22.5-MW wave energy facility is also planned for Scotland, with the first phase targeted for 2006 [3]. Figure 2.6 below show the Pelamis Wave Energy Converter.

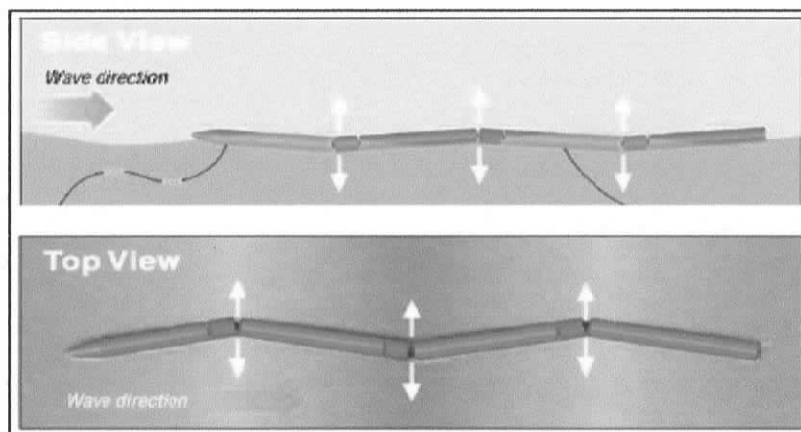
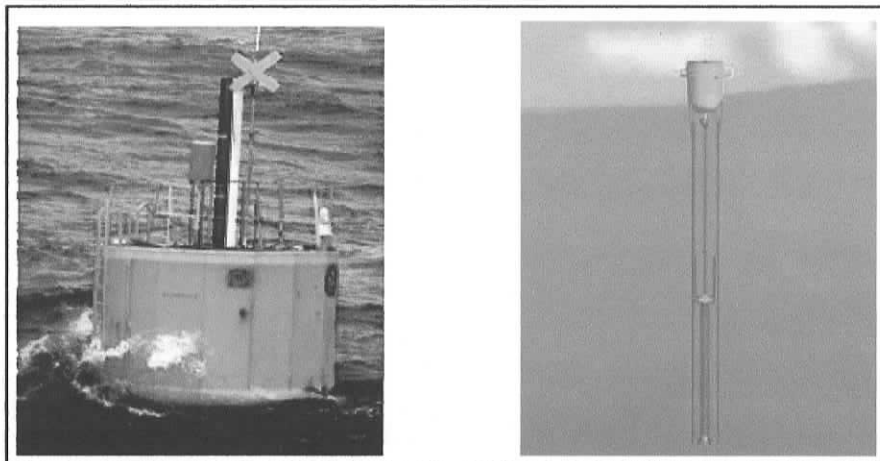

**Figure 2.6:** Pelamis Wave Energy Converter [3]

### 2.1.2.3 Points Absorbed

Point absorbers have a small horizontal dimension compared with the vertical dimension and utilize the rise and fall of the wave height at a single point for wave energy converter. One of example of this points absorbed is Aqua Buoy.

The Aqua Buoy being developed by the AquaEnergy Group, Ltd. In year 2005 this point absorber is the third generation of two Swedish designs that utilize the wave energy to pressurize a fluid that is then used to drive a turbine generator. The vertical movement of the buoy drives a broad, neutrally buoyant disk acting as a water piston contained in a long tube beneath the buoy. The water piston motion in turn elongates and relaxes a hose containing seawater, and the change in hose volume acts as a pump to pressurize the seawater. The Aqua Buoy design has been tested using a full-scale prototype, and a 1-MW pilot offshore demonstration power plant is being developed offshore at Makah Bay, Washington. The Makah Bay demonstration will include four units rated at 250 kW placed 5.9 km offshore in water approximately 46 m deep [3]. The Aqua Buoy Point Absorber Wave Energy Converter is show in Figure 2.7 below.



**Figure 2.7:** Aqua Buoy Point Absorber Wave Energy [3]