

**DESIGN AN EMBEDDED CONTROLLER
(SWIMMING POOL PUMP TIMER)**

ZAMANI BIN MEKAN

MAY 2008

DESIGN EMBEDDED CONTROLLER

ZAMANI BIN MEKAN

This Report Is Submitted In Partial Fulfillment of Requirements for The Degree of
Bachelor In Electrical Engineering (Industrial Power)

Faculty of Electrical Engineering
Universiti Teknikal Malaysia Melaka

May 2008

“I hereby declared that I have read through this report and found that it has comply the partial fulfillment for awarding the degree of Bachelor of Electrical Engineering (Industrial Power)”

Signature :

Supervisor's Name : Pn Ainain Nur Bt Hanafi

Date : 7 May 2008

“I hereby declared that this report as a result of my own work except for the excerpts that have been cited clearly in the references.”

Signature :

Name : Zamani Bin Mekan

Date : 7 May 2008

Specially dedicated to my beloved family,

Mekan Bin Tahir

Khalifah Binti Abd. Halim

Mazli Haizam Bin Mekan

Marliza Hana Binti Mekan

Safuan Bin Mekan

Mohd Farik Bin Mekan

Maizatul Syuhada Binti Mekan

Mohd Fahmi Bin Mekan

For Puan Ainain Nur Binti Hanafi, all lecturers, technicians and all my friends especially Noor Arbaieah Binti Abas @ Zahari, thanks for their support and guidance. Thank you.

Zamani Bin Mekan

Faculty of Electrical Engineering, UTEM

June 2004 – May 2008

ACKNOWLEDGEMENTS

Assalamualaikum W.B.T.

First of all I would like to thank to Allah SWT because for His blessing and help, I have completed my final year project successfully.

I would like to take this opportunity to express our deepest regards to Puan Ainian Nur Hanafi as my supervisor for this project.

I also would like to extent my thanks to my beloved family for their patience and understanding thought out my studies in UTeM. Not forgotten to all my members in UTeM for generosity in spending time and providing a lot of commitment in the way to finish this project and also giving as well as sharing the experience, advice, opinions and encouragement in process to complete this task.

Last but not least, my thanks goes to the person who directly and indirectly involved and contributed in competing this project. Thanks all.

ABSTRACT

This project is to build swimming-pool timer control school age or deep water rotation swimming-pool. Power input is 9-12V DC from converter. Powerful pump half horsepower engine single phase AC control by relay electrical switch. Switch relay electric control by the unit guard are situated in weather proof box nearby with pump. Consumer may prescribe amount of time for stated pump open and fall shut.

ABSTRAK

Projek ini adalah membina penentu masa kolam renang yang mengawal masa aliran atau pusingan air dalam kolam renang. Input kuasa adalah 9-12V DC daripada pengubah. Pam berkuasa setengah kuasa kuda satu fasa enjin AC dikawal oleh geganti suis elektrik. Geganti suis elektrik dikawal oleh unit pengawal yang terletak dalam kotak kalis cuaca berdekatan dengan pam. Pengguna boleh menetapkan jumlah masa bagi pam tersebut buka dan tutup.

TABLE OF CONTENT

CHAPTER	CONTENT	PAGE
	ACKNOWLEDGEMENTS	v
	ABSTRACT	vi
	TABLE CONTENTS	viii
	LIST OF FIGURES	x
	LIST OF TABLE	xi
1	INTRODUCTION	2
	1.1 Overview	2
	1.2 Project Objective	2
	1.3 Problem Statement	3
	1.4 Scope of Project	3
2	LITERATURE REVIEW	
	2.1 Embedded System	4
	2.2 Introduction of Microcontroller	5
	2.3 Multiple Seven-Segment LED Displays	5

CHAPTER	CONTENT	PAGE
	2.4 Controller	7
3	METHODOLOGY	
	3.1 Flowchart	11
	3.2 Literature Review	12
	3.3 Identifying Component	13
	3.4 Simulation	13
	3.5 System running	13
4	RESULT AND DISCUSSION	
	4.1 Introduction	15
	4.2 Programming	15
	4.3 Project Achievement	16
	4.4 Simulation	17
	4.5 Programming	18
	4.6 Installation and Soldering the Circuit	26
	4.7 Master the C Language for Programming	30
	4.8 Discussion	30
5	CONCLUSION	32
	5.1 Conclusion	32

	REFERENCE	33
CHAPTER	CONTENT	PAGE
	APPENDIXES	34

LIST OF FIGURE

NO	TITLE	PAGE
2.1	Seven-Segment Display	6
2.2	Binary to BCD decoder circuit	6
2.3	Binary to BCD decoder circuit	7
2.4	PIC 16F877 Pin Diagram	9
2.5	Figure 2.5: PIC16F877 Block Diagram	10
3.1	Project Flowchart	15
4.1	Port D and C on PIC16F877	16
4.2	Controller and programmer circuit	29
4.3	Seven segment display	30
4.4	Power Supply	31
4.5	Programming and controller circuit diagram	32

LIST OF TABLE

NO	TITLE	PAGE
4.1	Simulation Process	17

CHAPTER 1

INTRODUCTION

This project report consists of five chapters, chapter one is introduction, chapter two literature review, chapter three methodology, chapter four results and discussion and chapter five is the conclusion. Chapter one will be explain about the project overview. This chapter also states the problem for the project, objective and scope of the project report.

Chapter two will discuss about the theory and circuit analysis, there are four parts in this chapter to be discuss. First part about the theory of embedded system. Second part is about the introduction of microcontroller. Third part is about circuit description and fourth about user interface.

Chapter three is the methodology for the whole processes of projects from PSM I until PSM II. In project methodology will explain the whole project. For simulation method will explain the step of simulation project circuit.

In chapter four is discussing about the project result, this chapter consist of simulation and project result. Finally the chapter five is the conclusion of the whole project report and suggestions.

1.1 Overview

This project is to build a swimming pool pump timer using microcontroller technology. The timer cycles the AC pump motor on a swimming pool. The pump is a single-phase AC motor controlled by mechanical relay. Microcontroller will be used to control the relay and digital time display. Microcontroller which is used is PIC 16F877 and using C-language.

1.2 Project Objective

There is also having some objective from my final project that must be accomplish. Next are the objectives of my final project:

- To obtain knowledge of Microcontroller and its application.
- To create a new idea based on Microcontroller approach.
- To develop a swimming pool pump timer.

1.3 Problem Statement

Each of the projects has their own problem to be discussing before starting the project. By stating the problem statement it easy to know the purpose of doing this project and what are the problem to be solved. Swimming pool pump timer that use today is use mechanical relay as the main part. I try to change the system and use the computer technology to replace the mechanical relay.

1.4 Scope of Project

This project is base on the hardware and using microcontroller as the main part. I need to build and complete the hardware to complete this project. I need to build a swimming pool pump timer.

CHAPTER 2

LITERATURE REVIEW

2.1 Embedded System

Embedded systems are designed to do some specific task, rather than be a general-purpose computer for multiple tasks. Some also have real-time performance constraints that must be met, for reason such as safety and usability; others may have low or no performance requirements, allowing the system hardware to be simplified to reduce costs.

Embedded systems are not always separate devices. Most often they are physically built-in to the devices they control.

The software written for embedded systems is often called firmware, and is stored in read-only memory or Flash memory chips rather than a disk drive. It often runs

with limited computer hardware resources: small or no keyboard, screen, and little memory.

2.2 Introduction Of Microcontroller

A microcontroller is a computer-on-a-chip. It is a type of microprocessor emphasizing self-sufficiency and cost-effectiveness, in contrast to a general-purpose microprocessor (the kind used in a PC). In addition to all arithmetic and logic elements of a general purpose microprocessor, the microcontroller usually also integrates additional elements such as read-only and read-write memory, and input/output interfaces.

Microcontrollers are frequently used in automatically controlled products and devices, such as automobile engine control systems, office machines, appliances, power tools, and toys. By reducing the size, cost, and power consumption compared to a design using a separate microprocessor, memory, and input/output devices, microcontrollers make it economical to electronically control many more processes.

2.3 Multiple Seven-Segment LED Displays

A seven-segment display (abbreviation: "7-seg(ment) display"), less commonly known as a seven-segment indicator, is a form of display device that is an alternative to the more complex dot-matrix displays. Seven-segment displays are commonly used in

electronics as a method of displaying decimal numeric feedback on the internal operations of devices [6].

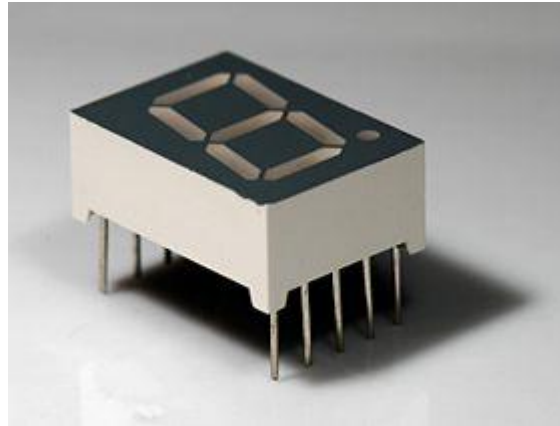

Figure 2.1: Seven-Segment Display

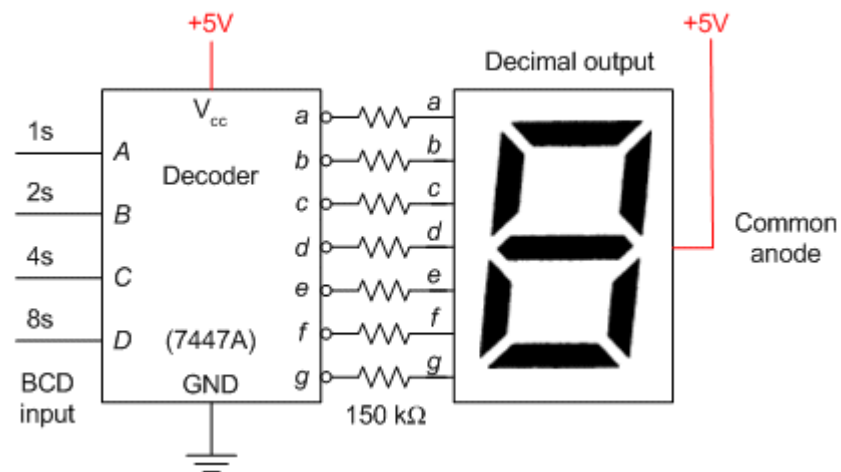

Figure 2.2: Binary to BCD decoder circuit

2.4 Controller

Microcontroller that used in this project is PIC16F877. PIC is stand for Peripheral Interface Controller. This PIC is used to control the signal control for gateway logic and switch.



Figure 2.3: PIC16F877

PIC also needs low voltage which is 5 volts and it can be programmed using C-language. It was computer in the chip which created to control electronic device. It also may be simulated support with the Proteus program and it cost-effective and easy operand. Besides, it contains all memory and I / O to the simple application.

The advantages of microcontroller PIC16F877 are:

- High performance RISC CPU
- Only 35 single word instructions to learn
- All single cycle instructions except for program branches which are two cycle
- Operating speed: DC - 20 MHz clock input

DC - 200 ns instruction cycle

- Up to 8K x 14 words of FLASH Program Memory,
Up to 368 x 8 bytes of Data Memory (RAM)
Up to 256 x 8 bytes of EEPROM Data Memory
- Pin out compatible to the PIC16C73B/74B/76/77
- Interrupt capability (up to 14 sources)
- Eight level deep hardware stack
- Direct, indirect and relative addressing modes
- Power-on Reset (POR)
- Power-up Timer (PWRT) and Oscillator Start-up Timer (OST)
- Watchdog Timer (WDT) with its own on-chip RC oscillator for reliable operation
- Programmable code protection
- Power saving SLEEP mode
- Selectable oscillator options
- Low power, high speed CMOS FLASH/EEPROM technology
- Fully static design
- In-Circuit Serial Programming (ICSP) via two pins
- Single 5V In-Circuit Serial Programming capability
- In-Circuit Debugging via two pins
- Processor read/write access to program memory

- Wide operating voltage range: 2.0V to 5.5V
- High Sink/Source Current: 25 mA
- Commercial, Industrial and Extended temperature ranges
- Low-power consumption:
 - < 0.6 mA typical @ 3V, 4 MHz
 - 20 μ A typical @ 3V, 32 kHz
 - < 1 μ A typical standby current

* This PIC's function data taken from the PIC16F877A's specification data sheet from Microchip Inc.

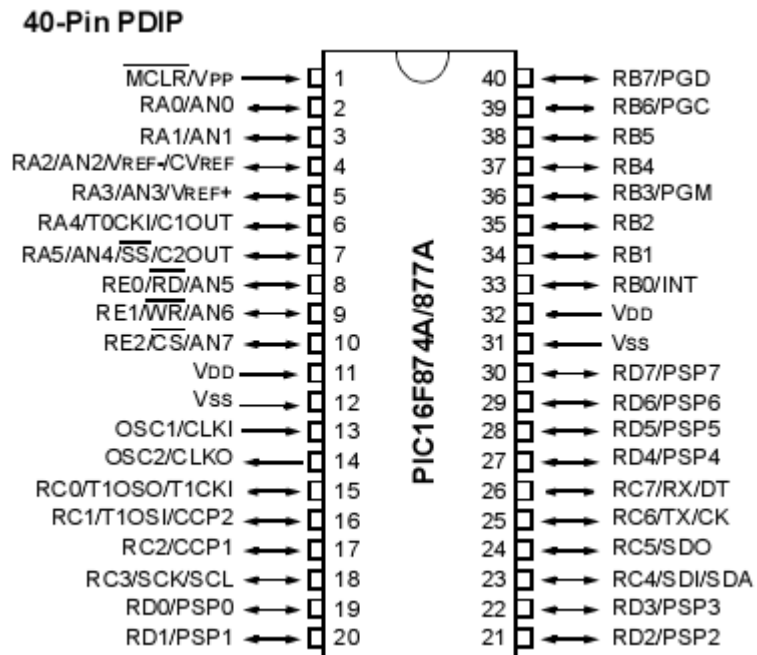

Figure 2.4: PIC 16F877 Pin Diagram

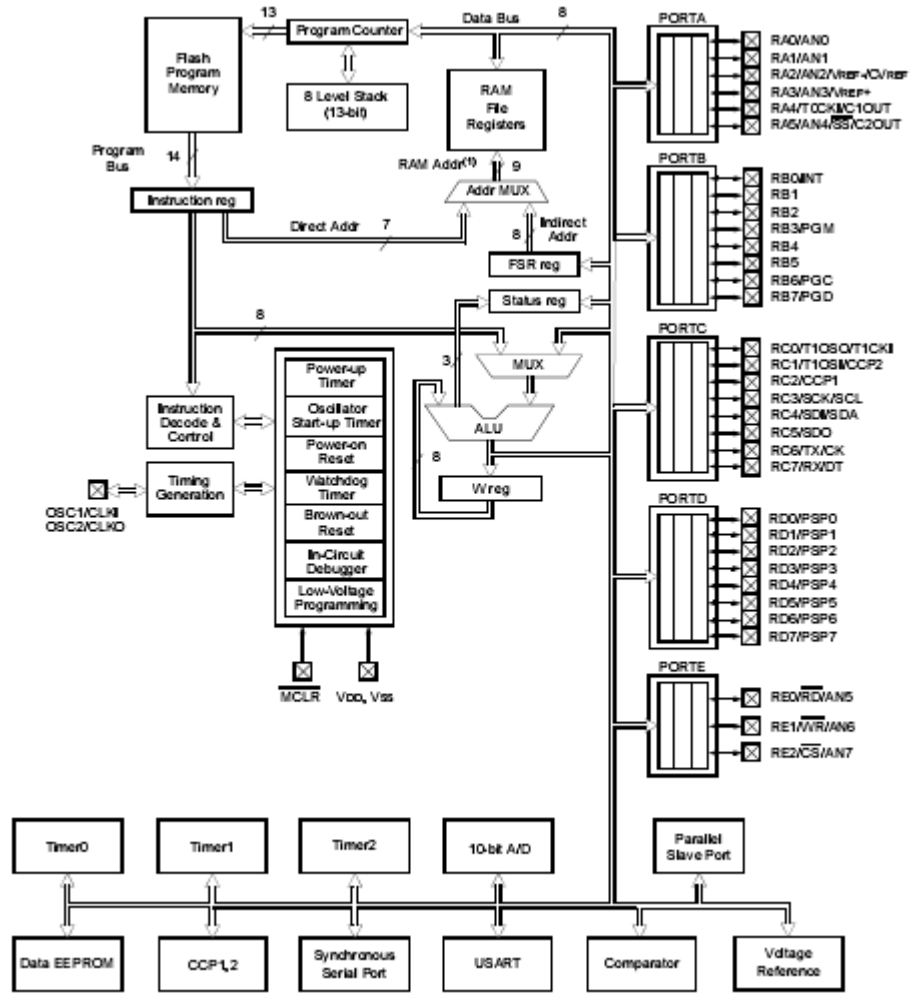

Figure 2.5: PIC16F877 Block Diagram

CHAPTER 3

METHODOLOGY

3.1 Flowchart

