

**SOFTWARE DEVELOPMENT FOR INDUCTION
MOTOR APPLICATION**

ADIBAH BINTI HASANUDDIN

POWER ELECTRONIC AND DRIVES

APRIL 2009

SOFTWARE DEVELOPMENT FOR INDUCTION MOTOR

ADIBAH BINTI HASANUDDIN

**This Report Is Submitted In Partial Fulfillment of Requirements for the Degree
of
Bachelor in Electrical Engineering (Power Electronics & Drive)**

**Fakulti Kejuruteraan Elektrik
Universiti Teknikal Malaysia Melaka**

APRIL 2009

“I hereby declared that this report is a result of my own work except for the excerpts that have been cited clearly in the references.”

Signature : 

Name : ADIBAH BINTI HASANUDDIN

Date : APRIL 2009

“I hereby declare that I have read this report and in my opinion this report in term of content and quality requirement fulfils the purpose for the conferring of the Degree of Bachelor in Electrical Engineering.”

Signature : 
Name of Supervisor : MRS. WAHIDAH BINTI ABD HALIM
Date : APRIL 2009

DEDICATION

Specially dedicated to my beloved family especially my mother (Azizah binti Ramli) and my father (Hasanuddin bin Abd Aziz); whose very concern, understanding, supporting and patient. To the very thanx to Pn Wahidah who supervise me one year in getting all done. Thanks for everything. To All My Friends, thanks for everything. This work and success will never be achieved without all of you.

ACKNOWLEDGEMENTS

Thanks to Allah S.W.T for give me an enthusiasm for completing this PSM 2 smoothly.

Special thanks to the important person, my supervisor whose guides me in the thesis and project preparation, Mrs Wahidah bt Abd Halim. The person that gave me a lot of advices and guidelines to make sure this project can be performed smoothly without any problem and produce the best result and also sharing his knowledge and idea for completing this project and her constructive criticisms and suggestions to prepare a good and quality of report.

I would like to appreciate to my parents and family which always give a motivation and encourage me to become a dean list student because without their support, it won't be easy for me to complete the project report.

Also not forget to all the lecturers of Universiti Teknikal Malaysia Melaka (UTeM) especially at Faculty of Electrical Engineering and all of my friends for the motivation and information to me. Thank you for all the help and support that was given. I'm really appreciated it.

Thank you.

ABSTRACT

Induction motor is a type of an AC motor and widely use because of its simplicity and ease operation. There are 2 types of induction motor. Commonly use in industry is squirrel – cage induction motor. Then the other one is wound-rotor induction motor. It rarely use because more expansive, need more maintenance and require a more complex automatic control circuit than squirrel-cage .In this project, it more concentrate on the characteristic of an induction motor. The only important thing that should be clear is about induced torque (stating current) and speed (synchronous speed). From the characteristic, there are few way to find the perfect induction motor with high starting torque, high starting current , low rotor resistance and good efficiency. The software that will be used in this project is labview. In this program it will show the voltage meter , current meter ,the flow of current ,the exact waveform from the value inserted and the right calculation. For induction motor of the project objective is to make the easier way for student to learn more about the characteristic of induction motor rather than doing experiment in laboratory. The expected result from this project is be able to create a program that can show all the characteristic of the induction motor, the waveform and calculation of an induction.

ABSTRAK

Motor pearuh ialah salah satu di antar motor arus terus dan kebanyakan digunakan kerana ianya mudah dah mudah beroperasi. Terdapat dua jenis motor pearuh iaitu jenis sangkar tupai atau rotor 'wound'. Rotor jenis 'wound' jarang digunakan kerana sifatnya lebih kompleks dan mahal jika dibandingkan dengan rotor sangkar tupai. Dalam projek ini, ia lebih memfokuskan di bahagian cirri-ciri sebuah motor pearuh. Dari ciri-ciri motor, adalah lebih baik mengetahui dengan jelas tentang bagaimana ingin mendapatkan motor yang baik dengan mempunyai arus mula yang tinggi, rintangan rotor yang rendah dan lebih effisiensi. Perisian yang digunakan semasa menjalankan project ini ialah LabVIEW. Perisian ini lebih menarik berbanding perisian yang lain kerana kebolehannya menunjukkan bacaan dari segi digital dan peralatan contohnya meter. Dalam perisian ini, ia dapat menunjukkan bacaan selepas pengiraan dan menunjukkan ia keputusan dalam bentuk graf. Objektif bagi project ini ialah membuat satu perisian yang dapat membantu pengguna terutamanya pelajar mempelajari dengan lebih mudah berkenaan motor pearuh. Keputusan yang dijangkakan ialah, perisian ini dapat menunjukkan cirri-ciri motor pearuh dengan menunjukkan graf dan kiraan berkenaan dengan motor pearuh.

CONTENTS

CHAP	TITLE	PAGES
	PROJECT TITLE	i
	STUDENT DECLARATION	ii
	SUPERVISOR DECLARATION	iii
	DEDICATION	iv
	ACKNOWLEDGEMENT	v
	ABSTRACT	vi
	LIST OF FIGURE	xii
	LIST OF APPENDIX	xiii
I	INTRODUCTION	
	1.1 Project Introduction	1
	1.2 Objective	2
	1.3 Problem Statement	3
	1.4 Scope of Work	3
II	LITERATURE REVIEW	
	2.0 History of Induction Motor	4
	2.1 Construction of Induction Motor	5
	2.1.1 Stator Construction	5
	2.1.2 Rotor Construction	7
	2.2 Characteristic of an Induction Motor	10
	2.2.1 Controlling Speed of an Induction Motor	10

2.1.1.1 Line Frequency	10
2.1.1.2 Number of Poles	11
2.1.1.3 Line Voltage	12
2.1.1.4 Rotor Resistance (wound-rotor)	13
2.3 Controlling the Induction Motor Characteristic	13
2.4 Parameter Test for Equivalent Circuit	16
2.4.1 Dc Test	16
2.4.2 No load Test	17
2.4.3 Blocked Rotor Test	18
2.6.4 Equivalent Circuit for Induction Motor	19

III RESEARCH METHODOLOGY

3.1 Project Methodology	21
3.2 Flowchart	23
3.3 Practical Test	25
3.4 Labview Software	26
3.4.1 What is Labview	26
3.4.2 Step Creating Front Panel	26
3.5.1 Creating The Front Panel	29
3.5.1.1 Procedur To Create Icons In The Front Panel	30
3.6 Creating the Block Diagram	32
3.7 Flowchart of Process or Subtopic	34
3.8 Calculation in Labview	35

IV RESULT & DISCUSSION

4.1 Results for Parameter Test	36
4.1.1 Dc Test or Stator Resistance	37
4.1.2 No load Rotor Test	38

4.1.3 Blocked Rotor Test	39
4.2 Performance Characteristic	41
4.2.1 Result of Performance Characteristics	42
4.3 The Result from Matlab	49
4.4 Discussion	52

V **DISCUSSION AND CONCLUSION**

5.1 Conclusion	53
5.2 Recommendation	54
REFERENCES	55
APPENDICES	56

LIST OF APPENDICES

APPENDIX	TITLE	PAGE
A	Experiment 2A lab sheet	56
B	Journal about Matlab and Induction Machine	60

LIST OF FIGURES

FIGURE	TITLE	PAGE
2.1:	Parts of induction motor	5
2.2:	Diagram of stator; (a) stator lamination,(b) stator winding	6
2.3:	Diagram of a rotor bars for squirrel cage (a) for small motor, (b) For big squirrel motor	8
2.4:	Image of wound- rotor motor and its rotors bars	9
2.5:	Connection of 3-phase; (a) squirrel cage rotor,(b) wound-rotor motor	9
2.6:	Variable-line-voltage speed control in an induction motor	13
2.7	A torque-speed characteristic curve combining high-resistance effects at low speed (high slip) with low-resistance effects at high speed (low slip)	14
2.8:	A lamination from typical squirrel cage induction motor rotors, the cross section of this rotor bars. (a) design A,(b) design b, (c) design c,(d) design d	15
2.9	Typical torque-speed curves for different rotor designs	15
2.10:	Experimental setup for dc test	16
2.11	: dc test	16
2.12:	Experimental setup of the no load test	17
2.13:	Equivalent Circuit for Induction Motor	20
3.01	connection of No load test	25
3.02	Motor that attached with weights use in blocked rotor test	25
3.1	Starting windows for LabVIEW 7.0	27
3.2	Windows for getting new blank VI for front panel	27
3.3	Windows for selecting 'show control palette'	28
3.4	These are the control palette after step above	28
3.5	One of front panel for this project	29
3.6	Nodes , 2.indicator terminals , 3.wires , 4.control terminals	30

FIGURE	TITLE	PAGE
3.7	The part of a front panel	31
3.8	Windows Of Control Palette	31
3.9	Block diagram for first front panel	32
3.10	Front panel in choosing subtopic	32
3.11	block digram with stacked sequence structure	33
3.12	maths equation block digram for block rotor test.	35
4.0	Front Panel of Dc Test	37
4.1	No Load Test Menu	37
4.2	Front Panel for No Load Test	38
4.3	No Load parameter panel	38
4.4	Blocked rotor theory front panel	39
4.5	Blocked Rotor Test	39
4.6	Blocked rotor parameter	40
4.7	Performances characteristic of induction motor	40
4.8	Front Panel in viewing performance characteristic CCP	41
4.9	Plotting graph A, B, C, D, E, F, G versus slips from current circuit parameter,	42
4.10	Front panel for different external resistance	42
4.11	Plotting graph A, B, C, D, E, F, G versus slips from different external resistances	45
4.12	Front panel for different stator voltage	45
4.13	Plotting graph A, B, C, D, E, F, G versus slips from different stator voltage	47
4.14	Front panel for different supply frequencies	47
4.15	Plotting graph A, B, C, D, E, F, G versus slips from different supply frequencies	48
4.16	The output of dropping voltage 20% from supply voltage	50
4.17	Effect of varying frequency	51

CHAPTER 1

INTRODUCTION

The purpose of this project is to develop programming software for induction motor application. It consists about characteristic of induction motor in a few aspects. This chapter contains objective, project scope and problem statement of the project. These would explain in surface about the project.

1.1 Problem Statement

Laboratory test or experiment usually been done with normal procedure. The first step is running the equipment. Then write down the result and do some calculation. Some of those experiments need to plot a graph.

The problem to be encountered is making an easy way to do second step of laboratory procedure which are calculation and plotting graph or else in editing result from experiment been done to make it more relevant. Student also can run the programming as picture of exact experiment before does it practically. This programming also can help student in plotting graph more accurate and reduce parallax error.

In the other hands, students are not familiar with a laboratory environment that contains large machines and relatively complex measurement methods and devices as compared with other laboratories they have been to before. The time constraints during the laboratory exercise are also a difficult adjustment. In a usual two-hour laboratory section, students are required to set up and perform four induction motor experiments, to take the necessary measurements, and to investigate steady-state performance of the motor under various loading conditions. Because of the time limitations, students often rush through the experiments in order to finish them on time, which unfortunately prevents them from getting a true feeling of motor operation and from appreciating what has been accomplished during the laboratory practice.

Besides, this programming would help student in getting know about induction motor details in its characteristic or performance. It would help more in their studies about induction motor including of it performance and calculation. In the mean time, it would improve students' programming skills that would be helpful in other classes as well.

1.2 Project Objective

Each of a project should have an objective. These project objectives are:

- a) To demonstrate laboratory experiment in programming software relates in induction motor scope. .
- b) To demonstrate new software ,Labview in implementing induction motor practical test
- c) To design programming software which can do calculation and plotting graph relates to induction motor performances.

1.3 Scope of the Project

In order to design this software, which it capable to solve related calculation according to few tests, plotting graphs and creates an equivalent circuit of induction motor. Theory of induction motor would be as references in designing this programming software. Thus, the scopes of the project are:

- a) To demonstrate a 3 phase induction motor laboratory experiment in a software.
- b) To demonstrate circuit model parameter by a few test parameter in induction motor.
- c) To introduce tools in Labview software that can be implementing in induction motor application.
- d) To show induction motor performance in new software, Labview compare with Matlab software.

CHAPTER 2

LITERATURE REVIEW

Induction machines represent a class of rotating apparatus that includes induction motor, induction generator, induction frequency generator, induction phase converters and electromagnetic slip coupling. They are more rugged, requires less maintenance and are less expensive than direct current motors of equal power and speed ratings.[3]

This three phase induction motor was patented by Nikola Tesla in 1888 and currently accounts for over 90% of the motors used in industry.[1].Other source said that the induction motor with a wrapped rotor was invented by Nikola Tesla in 1882 in France but the initial patent was issued in 1888 after Tesla had moved to the United States. In his scientific work, Tesla laid the foundations for understanding the way the motor operates. The induction motor with a cage was invented by Mikhail Dolivo-Dobrovolsky about a year later in Europe. Technological development in the field has improved to where a 100 hp (73.6 kW) motor from 1976 takes the same volume as a 7.5 hp (5.5 kW) motor did in 1897.[2]

The torque speed characteristic of an induction motor is directly related to the resistance and reactance of the rotor. Hence, different torque-speed characteristics may be obtained by designing rotor circuit with different ratio rotor resistances and rotor reactance.[3]

2.1 Construction of Induction Motor

There are 3 basic parts which are rotor, stator and enclosure. The stator and the rotor are electrical circuits that perform as electromagnets. Figure 2.1 show the rotor and stator which are inside the enclosure. The drive end is connecting to a load and the non drive end have fan for cooling system in motor.

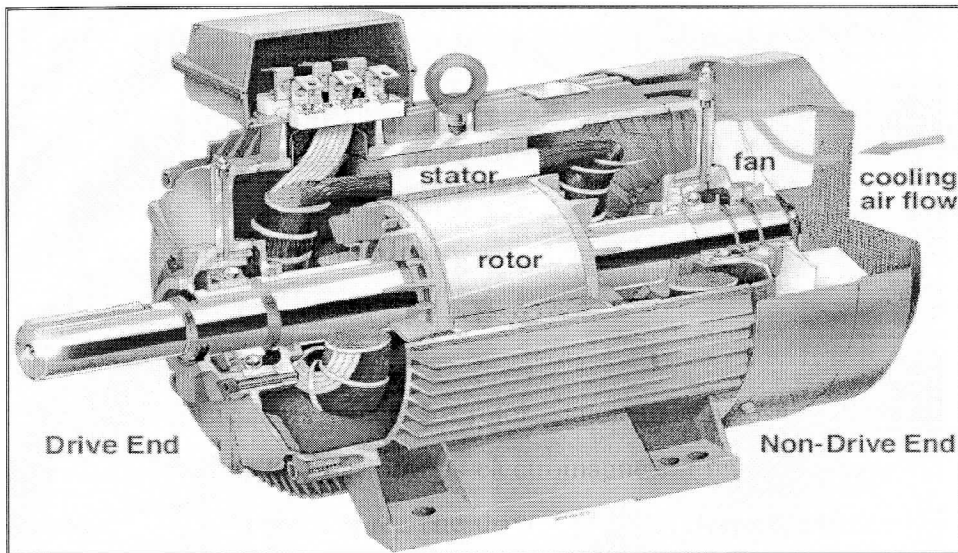

Figure 2.1: Parts of induction motor

2.1.1 Stator Construction

The stator or primary (stationary portion) of induction motor consist of a frame that houses a magnetically active, annular cylindrical structure (stator lamination stack) punched from electrical steel sheet with a three-phase winding set embedded in evenly spaced, internal slots. The stator is the stationary electrical part of the motor. The stator core of a National Electrical Manufacturers Association (NEMA) motor is made up of several hundred thin laminations. Stator laminations are stacked together forming a hollow cylinder. Coils of insulated wire are inserted into slots of the stator core. [1]

Electromagnetism is the principle behind motor operation. Each grouping of coils, together with the steel core it surrounds, form an electromagnet. The stator windings are connected directly to the power source. The individual coils of this electrical winding are random-wound for smaller motors and form-wound for larger motors. A random-wound coil can be of this same design, or it may be wound by automation in situ rather than being formed externally for insertion in the stator slots as individual unit. [1]

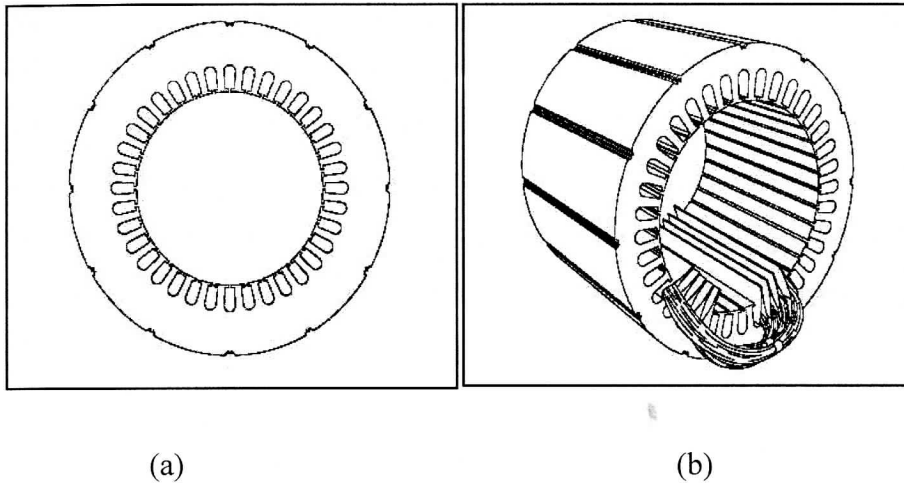

Figure 2.2: Diagram of stator; (a) stator lamination,(b) stator winding

Figure 2.2(a) show the lamination of an induction motor. The stator and the rotor are electrical circuits that perform as electromagnets. The stator is the stationary electrical part of the motor. The stator core of a NEMA motor is made up of several hundred thin laminations. Stator laminations are stacked together forming a hollow cylinder. Figure 2.2(b) shows coils of insulated wire are inserted into slots of the stator core. Each grouping of coils, together with the steel core it surrounds, form an electromagnet. Electromagnetism is the principle behind motor operation. The stator windings are connected directly to the power source.[1]

2.1.2 Rotor Construction

The rotor is the rotating part of the electromagnetic circuit. The most common type of rotor is the "squirrel cage" rotor. Other types of rotor construction are wound-rotor motor that will discuss in detail after this.

Squirrel cage is far more common and will be the rotor type dealt with in this class. A squirrel cage rotor is constructed using a number of short-circuited bars arranged in a 'hamster-wheel' or 'squirrel-cage' arrangement. The squirrel-cage rotor is made up of copper or aluminum bars embedded in the rotor slots. Bars are shorted at both ends by end rings. The skewing is done to produce a more uniform torque and to reduce the noise during operation. Squirrel-cage rotor forms a solid block as the bars and rings are die-cast in aluminum (for small motors).[1]

The construction of the squirrel cage rotor is reminiscent of rotating exercise wheels found in cages of pet rodents. Rotor is a part which is moving and cutting flux and produced current. The rotor consists of a stack of steel laminations with evenly spaced conductor bars around the circumference. The laminations are stacked together to form a rotor core. Aluminium is die cast in the slots of the rotor core to form a series of conductors around the perimeter of the rotor. Current flows through the conductors form the electromagnet. The conductor bars are mechanically and electrically connected with end rings. The rotor core mounts on a steel shaft to form a rotor assembly.[3]

Figure 2.3 shows the rotor of a small and a large motor. Both rotors have laminated cores with slots, mounted on a shaft. The aluminum bars are slanted on the small rotor. This reduces the noise and improves performance. Fins are placed on the ring that shorts the bars. The fins work as a fan and improve cooling. The large rotor also has fins and bars. But the bars are not slanted.[5]

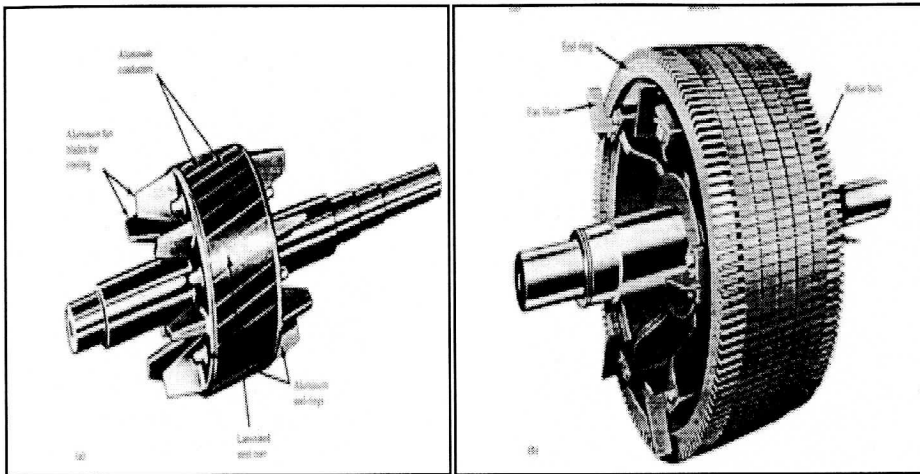

Figure 2.3: Diagram of a rotor bars for squirrel cage (a) for small motor,
(b) For big squirrel motor

Wound Rotor Motors are sort of a unique animal due to the fact that they are the only type of AC motor that allows you to vary its output torque when operated at full line voltage. The variability of the output torque in a Wound Rotor Motor is achieved by controlling the strength of the magnetic fields in the motor's rotor. The torque is varied by means of changing the resistance to the flow of the electrical currents circulated in the rotor. Wound- rotor motor is three-phase winding similar to the stator and has the same number of poles as the stator winding. The rotor winding terminates in 3 slip rings mounted on the shaft. Brushes ride on the slip rings, which allow external resistance to be connected in series with rotor winding to get high starting torque during start up and for speed control. Figure 2.4 shows the actual wound rotor motor and its position in induction motor.[5]

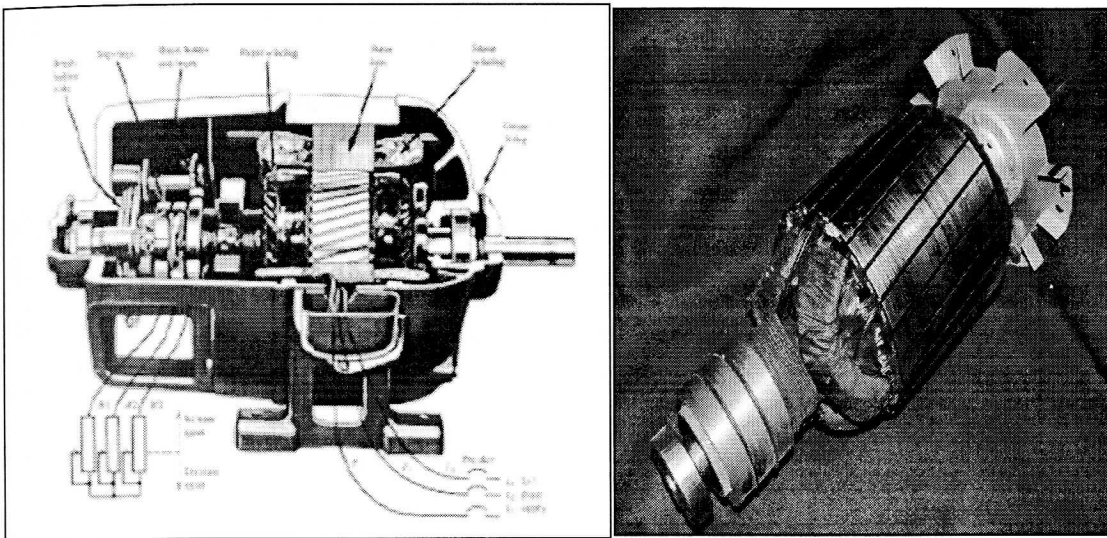

Figure 2.4: Image of wound- rotor motor and its rotors bars

The connection from 3 phase supply between these two rotor are also different for wound-rotor motor, it is three-phase windings are placed in the slots. The winding is wye or delta connected. The ends of each phase is connected to a slip ring. Three brushes contact the three slip-rings. The rotor winding may be loaded by variable resistance's or supplied by a separate power supply. For the squirrel-cage rotor motor, the stator has a ring shape laminated iron core with slots. A three or single-phase winding is placed in the slots. The rotor has a ring-shape laminated iron core, with slots bolted to the shaft. Figure 2.5 shows both connection 3-phase supply. [6]

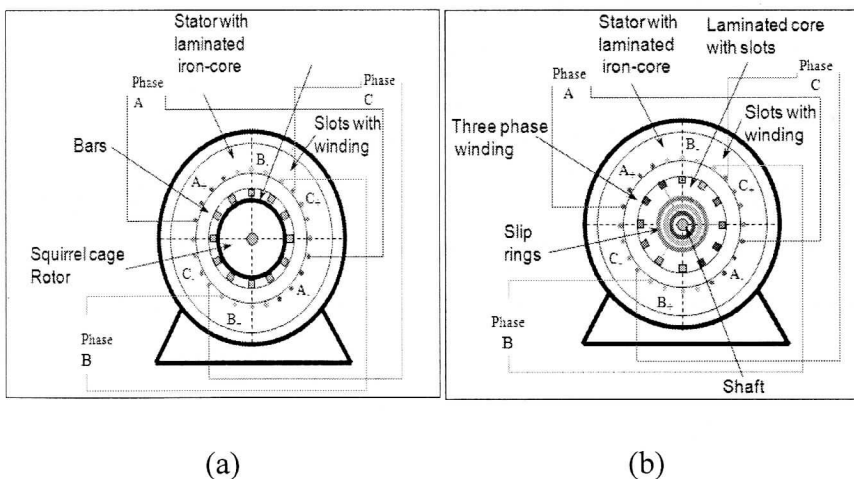

Figure 2.5: Connection of 3-phase; (a) squirrel cage rotor, (b) wound-rotor motor

From the equation state before, only two variables in this equation that define speed are the incoming line frequency and the number of poles in the machine. Usually the number of poles in a machine is fixed, the only variable that's left to change is the incoming line frequency. From the research in the internet, variable-frequency drive (VFD) is equipment used to vary frequency for controlling speed.

It's important to understand the difference between the AC and DC machine at this point. DC machine could have its speed changed by increasing or decreasing the applied voltage. This is not the case for an AC motor. In fact, you can damage an AC squirrel cage induction motor if you vary the incoming supply voltage.

2.2.1.2 Number of Poles

Every ac induction motor has poles, just like a magnet. However, unlike a simple magnet, these poles are formed by bundles of magnet wire (windings) wound together in slots of the stator core. In most cases, we can look inside the motor and count the number of poles in the winding. They are distinct bundles of wire evenly spaced around the stator core.

The number of poles, combined with the ac line frequency (Hertz, Hz), are all that determine the no-load revolutions per minute (rpm) of the motor. So, all four-pole motors will run at the same speed under no-load conditions, all six-pole motors will run at the same speed, and so on.

The example for calculating speed depends on the pole and fixed frequencies are:

1. For a 60-Hz system, the formula would be:

$$60 \times 60 \times 2 = 7,200 \text{ no-load rpm} \div \text{number of poles.}$$