

I declare that I have been done reading this report
and in my opinion, this report fulfill the condition in all
aspect that must be in project writing as need in partial fulfillment
for Bachelor of Mechanical Engineering (Thermal – Fluid)

Signature :

Supervisor Name : Mr. Mohamad Firdaus B. Sukri

Date :

THE SUITABILITY OF INVERTER AIR-CONDITIONING COMPARED TO
NON- INVERTER TYPE FOR HOUSEHOLD APPLICATION

RIZALMAN B. MAHMOOD

This report had been done
in partial fulfillment for
Bachelor of Mechanical Engineering (Thermal – Fluid)

Faculty of Mechanical Engineering
Universiti Teknikal Malaysia Melaka

APRIL 2011

“I declare that this report had been done originally from me except some of them where I have been explain each one of them with its sources”

Signature :

Name : Rizalman b. Mahmood

Date :

Especially to my beloved parents,
My respectfully lecturers,
Also my faithfully friends,
Your prayers always with me every way that I went...

ACKNOWLEDGEMENT

First of all, thanks to ALLAH S.W.T for his mercy and guidance in giving me full strength to complete this final year project. Even facing with some difficulties in completing this project, I still managed to complete it.

Secondly, I would like to thanks to my supervisor, Encik Mohamad Firdaus b. Sukri, lecturer of Mechanical Faculty in UTeM for all of his support and guidance in helping me to finish my project that really tested my abilities mentally and physically.

I also would like to thank to all my friends especially class of 4BMCT (G1) for being kind and helpful to me until the project done. They have been helping me doing research for this project.

Lastly, thank to my beloved parents who had give me encouragement until this project done. I hope that this report will be a guide and reference to other students and researchers soon.

Thanks

ABSTRACT

This project is focused on a comparison between the two types of air conditioner, inverter and a non-inverter. The difference between the two types of air conditioning has resulted in many users difficulting to determine the suitability of the air conditioner required. Inverter type air conditioner usually known as an air conditioner with a new technology provides energy savings thus lead to lower electricity cost, but in terms of price per unit is relatively expensive. In contrast to non-inverter type air conditioner, this unit is known as a conventional air conditioner (normal type). Non-inverter type air conditioner uses more energy, indirect energy use is high. In terms of air-conditioning unit price is relatively cheap compared to inverter. In this project the two types of air conditioners were investigated in terms of cost and energy usage to determine the suitability of the air conditioner. Analysis of cost and energy consumption of the theory was based on 1.5 hp Panasonic split-unit air-conditioning. The purpose of data analysis is to investigate a payback period for inverter air conditioners by using cost analysis. Through this project, it is found that the payback period of inverter type air-conditioning is 4 year 5 months. This payback period is acceptable due to short period of payback period. The inverter air-conditioning is very suitable for the household application compared to non-inverter.

ABSTRAK

Projek ini memfokuskan kepada perbandingan di antara dua jenis penyaman udara iaitu jenis penyaman udara inverter dengan bukan inverter. Perbezaan kedua-dua jenis penyaman udara ini menyebabkan ramai pengguna sukar untuk menentukan kesesuaian penyaman udara yang di kehendaki. Penyaman udara jenis inverter biasanya di kenali sebagai penyaman udara yang berteknologi baru dengan memberikan penjimatan tenaga, tetapi dari segi harga seunit ianya agak mahal. Berbeza dengan jenis penyaman udara bukan inverter, unit ini di kenali sebagai penyaman udara yang konvensional (jenis biasa). Penyaman udara jenis bukan inverter menggunakan banyak tenaga, secara tidak langsung tenaga elektrik yang digunakan adalah tinggi. Dari segi harga seunit penyaman udara ini agak murah berbanding inverter. Kedua-dua jenis penyaman udara ini di buat kajian dari segi kos dan penggunaan tenaga untuk menentukan kesesuaian penyaman udara tersebut. Analisis kos dan teori penggunaan tenaga yang di buat berdasarkan kepada spesifikasi jenama penyaman udara Panasonic 1.5 hp (kuasa kuda) dengan membuat kajian kos keseluruhan bagi kedua jenis penyaman udara itu. Analisis data yang dibuat bertujuan untuk mendapatkan tempoh pulangan (payback period) bagi penyaman udara inverter. Tujuan dari analisis data adalah untuk mengetahui tempoh pulangan balik penyaman udara jenis inverter dengan menggunakan analisis kos. Melalui projek ini, didapati bahawa tempoh pulangan balik penyaman udara jenis inverter adalah 4 tahun 5 bulan. Tempoh pulangan ini diterima kerana hanya menggunakan selama 4 tahun 5 bulan, pengguna penyaman udara inverter boleh mendapatkan balik modal yang telah di belanjakan sebelum ini. Penyaman udara jenis inverter adalah lebih sesuai digunakan dalam penggunaan rumah berbanding dengan penyaman udara bukan inverter.

TABLE OF CONTENTS

CHAPTER	TITLE	PAGE
	DECLARATION	i-iv
	ACKNOWLEDGEMENT	v
	ABSTRACT	vi
	ABSTRAK	vii
	CONTENTS	viii-xi
	LIST OF TABLES	xii-xiii
	LIST OF FIGURES	xiv
CHAPTER 1	INTRODUCTION	1
	1.1 Objective of project	4
	1.2 Scope of project	5
	1.3 Problem statement	5
CHAPTER 2	LITERATURE REVIEW	6
	2.1 History of Air-Conditioning	6
	2.2 Air-Conditioning operation	6-7
	2.3 Inverter Technology	7
	2.4 Inverter in Electrical	8
	2.5 Inverter Control the Speed Compressor	8
	2.6 Assessment of the thermal environment effects	

on human comfort and health for the development of novel air conditioning system in tropical region.	9
2.7 Payback Period	9
2.8 Theoretical of Energy Consumption	9-10
2.9 Air-Conditioning System	10-11
2.10 Energy Saving	11
2.11 Air-Conditioning Operating Cost	12
2.12 Panasonic Launches Air-ECO SENSE I2 and P2 latest	12-13
2.13 Energy Saving Inverter Air-conditioning Panasonic	13-14
2.14 Inverter Air-conditioning Panasonic Quite mode	14-15
2.15 Inverter Variable Frequency Drive	15-16
2.16 How the split system Inverter Air-conditioning Push the Efficiency Envelope.	16-17
2.17 Comparison Air-condition	17-18
2.18 Energy Cost Calculation Sheet For Inverter Project MDDM Shah Alam Before Install Inverter and After Install Inverter Based on Monitoring Data for 1 month.	19-20
2.19 Payback period analysis	20-21
2.20 Time Value of Money	21
2.21 Internal Rate of Return (IRR)	21-22
2.22 Present Value	22
2.23 Interest Rate	22
2.24 Future Value	23

CHAPTER 3	METHODOLOGY	24
3.1	Methodology Chart	25
3.1.1	Data Cost Analysis	25
3.1.1.1	Example Data for Determine the Power Consumption.	26
3.1.1.2	Example Data for Air-conditioning price include Installation	27
3.1.1.3	Not include Installation	27
3.1.1.4	Wace Price List includes Copper Pipe insulation, Drain installation Testing for common.	28
3.1.1.5	Wage Price List Opens (Dismantle) Unit Air-Cond	28
3.1.1.6	Price of Various Types Of Wiring Installation	29
3.1.1.7	Maintenance (General Service)	29
3.1.1.8	Maintenance (Chemical Service)	30
3.1.1.9	Maintenance (Overhaul Service)	30
3.1.1.10	Adding Gases (Empty)	31
3.1.1.11	Adding Gases (Top up)	31
3.1.1.12	Change Motor Capacitor	32
3.1.2	Comparisons of Air-conditioning	32
3.1.3	Theory of energy consumption for air conditioning	32-34
3.1.4	Determine the Payback period	34
3.1.5	Analysis Result	35

CHAPTER 4	ANALYSIS AND RESULT	36
4.1	Cost survey for Inverter 1.5hp and Non-inverter 1.5hp Panasonic Brand	36-37
4.2	Data cost for inverter 1.5hp Panasonic and non-inverter after statistic	37-38
4.3	Electrical data from Panasonic brochure	38-40
4.4	Analysis Cost Comparison with two type Air-conditioning	40
4.4.1	Analysis cost for inverter for first year	41-42
4.4.2	Analysis cost for non-inverter for first year	43-44
4.4.3	Analysis cost for inverter for second year	45-46
4.4.4	Analysis cost for non-inverter for second year	47-48
4.5	Result Analysis	49-50
4.6	Graph from result analysis	50-52
CHAPTER 5	DISCUSSION AND RECOMMANDATION	53-55
CHAPTER 6	CONCLUSION	56
	REFERENCES	57-58
	APPENDIX A	59-64
	APPENDIX B	65-66

LIST OF TABLES

NO.	TITLE	PAGE
2.17(a)	1.5Hp Air-conditioner with Inverter	18
2.17(b)	1.5Hp Air-conditioning without Inverter	18
2.18	Total Energy Cost Saving	19
3.1.1.1(a)	Example Data for Inverter Air-conditioning	26
3.1.1.1(b)	Example Data for Non-Inverter Air-conditioning	26
3.1.1.2	Air-conditioning Brand Price	27
3.1.1.3	Price with not include Installation	27
3.1.1.4	List Price for Installation	28
3.1.1.5	List for Dismantle	28
3.1.1.6	Wiring	29
3.1.1.7	Service General Air-cond	29
3.1.1.8	Chemical Service	30
3.1.1.9	Overhaul Service	30
3.1.1.10	Add Gases	31
3.1.1.11	Top up Gases	31
3.1.1.12	Component	32
3.1.3	Tenaga Nasional Behad Tariff	34
4.1	Cost survey	37
4.2	Data cost	37-38

4.3	Electrical data from Panasonic brochure	38
4.4.1	Cost inverter for first year	43
4.4.2	Cost non-inverter for first year	45
4.4.3	Cost inverter for second year	47
4.4.4	Cost non-inverter for second year	49
4.5	Result from analysis	50
4.6	Graph analysis	53

LIST OF FIGURES

NO.	TITLE	PAGE
1.0 (1a)	Inverter air- conditioning split unit	2
1.0 (1b)	Inverter compressor	2
1.0 (2a)	Non inverter air- conditioning split unit	3
1.0 (2b)	Non- inverter compressor	4
2.3	Inverter Quick Comfort	7
2.4	Simple circuit with electromechanical switch and automatic equivalent	8
2.9	Basic cooling system	11
2.13	Comparision cumulative electricity consumption during heating and cooling	14
2.14	Quite mode inverter	15
2.15	Compressor	16
2.16	The control board of the heat-pump version of An inverter-rotary system.	17
3.1	Methodology Chart	25
4.4.1	Analysis cost for inverter for first year	42
4.4.2	Analysis cost for non-inverter for first year	44
4.4.3	Analysis cost for inverter for second year	46
4.4.4	Analysis cost for non-inverter for second year	48
4.6	Graph from result analysis	52
5.0	Graph for different between inverter and without inverter	55

CHAPTER 1

INTRODUCTION

The air conditioner is cooling the air in a closed area to get a comfortable temperature. Air conditioner usually refers to the cooling, heating, ventilation, which change the state air. It is a device, system, or machines that are designed to stabilize the temperature and humidity.

Currently, air conditioning has become one of the equipment needed of each household. Increasing demand led to the emergence of various brands on the market. Few brand of air conditioner in the market are Samsung, Sharp, Panasonic, Hitachi, Daikin and York. Every brand offers a variety of functions and advantages as anti bacteria, energy conservation, deodorization and others.

Now the air-conditioning has changed with the introduction of inverter air-conditioners. How to identify the type of inverter air-conditioner and non-inverter type:

1) Inverter air conditioning

- Inverter type air conditioner is a modification from the conventional to the new technology by changing the electric current from direct current to alternating current. Inverter type air conditioning system can vary the temperature by controlling the flow of compressor speed. The use of technology in an inverter air conditioner provides savings on energy and cooling speed in a room temperature. The cost for inverter type air conditioners is more expensive than

non-inverter and the cost of maintenance is also expensive (www.wikipedia.com). Figure 1.0 (1a) show below is the inverter air-conditioner indoor split unit model CS-S13MKH. This air-conditioner uses a new technology intelligent inverter in the system. Inverter has an eco sensor and petrol sensor to detect the cooling load and dirt in the room and can mild dry cooling. Figure 1.0 (1b) is the inverter compressor model CU-S13MKH (outdoor). Inverter compressor is very quite mode to run the compressor. Inverter compressor has been converting to use an electronic device that installed in the outdoor air-conditioning in order to control the speed of the compressor .The compressor inverter can make the room in home quick comfort.(Source from Panasonic brochure 2010)



Figure 1.0(1a): Inverter air- conditioning split unit
(Source: Panasonic brochure 2010)



Figure 1.0(1b): Inverter compressor
(Source from web site Panasonic 1.5hp inverter)

2) Non inverter air conditioning

Non-inverter air-conditioners is a conventional air conditioner (normal air air conditioning). It is cheaper than the inverter. Non-inverter type air conditioner uses more power than the inverter to turn the compressor. Power to turn the compressor is a constant temperature of the cooling process. Cost per unit for non-inverter type air conditioners are less expensive and the cost to repair is more expensive than an inverter type air conditioner. Figure 1.0 (2a) show below is the non-inverter air-conditioner model CS-S12MKH, the different of inverter and non-inverter is the non inverter not have new technology in the system and the current run maintain to get the thermal comfort in the space The design of inverter air-conditioning are old pattern and if see the housing of this air-conditioner not have label” inverter”. The compressor of non-inverter model CU-C12MKH is very noise show in figure 1.0 (2b).To identify the types of non-inverter compressor is not attached to any variation in outdoor air-conditioning. Compressor runs in standard condition without control speed.



Figure 1.0(2a): non inverter air- conditioning split unit
(Source from www.panasonics.com, “search image”)



Figure 1.0(2b): non inverter compressor
(Source www.panasonics.com, “search image”)

Most consumers tough to select or determine the suitability of any type of air conditioner they should buy. Thus, to solve this problem, a study is conducted to determine the suitability of these two types of air conditioners.

1.1 Objective

The objective of the project is to determine the payback period for inverter type air conditioning system. Payback period is the period during which a cost comparison for both types of air conditioners available is the same. Common ground for comparing the cost of it is designated as the payback period. It aims to determine the period or the year when the air conditioner can provide savings to consumers. To get a payback period of various methods can be done as a comparative cost analysis for both types of air through the appropriate calculations.

1.2 Scope

The scopes of this project are:

- Conduct a theoretical study to determine the energy consumption
- Conduct an engineering cost analysis
- Specification of air-conditioning Panasonic brand 1.5 hp.

1.3 Problem statement

There are two types of air conditioners in the market for the problem to the user to specify or select the type of air conditioner that they desire. Among them are the type of inverter, and the other is a non-inverter type air conditioner or regular type.

Installation for inverter type air conditioner is expensive, but in terms of cost of electricity it provides savings of 60% -70% due to air this kind use no more energy during the process of cooling the room refer from Panasonic brochure. For non-inverter type air conditioner, it is inexpensive in terms of installation and maintenance as compared with the inverter type, but the cost of electricity is higher than the inverter type air conditioner because of the huge energy consumption during the cooling process.

For these two types of air conditioner with the same power and cooling load, a cost analysis is necessary to determine the payback period of inverter air-conditioning. Through the payback period, justification can be done to determine which type is more economical. Therefore, the study was conducted for both types of air conditioners that have same specifications such as brand and the same energy.

CHAPTER 2

LITERATURE REVIEW

2.1 History of Air-Conditioning

According to Harry M. Will, Member ASHRAE (1980), beginning in the 1890s and continuing into the early 1900s, a spurt of technological development marked the true start of air conditioning as he now define it. Since then, steady progress has made the 1900s the first air-conditioned century. As he approach the start of a new century, and indeed a new millennium, air conditioning has evolved from a curiosity to a necessity, literally transforming the way that much of the world lives. This series is a testament to these achievements. Our current abilities are well founded on the initiative, engineering skill and enterprise of those who helped define and develop air conditioning. All involved today in professions that provide environmental control and comfort should be justly proud of the industry that grew from the contributors of these pioneers. (Source: ASHRAE journal 1998)

2.2 Air-Conditioning operation

According to Tim Padfield (2000), the essential ingredients in an air conditioning system are a fan to blow air around, a cold surface to cool and dehumidify the air, a

warm surface and a source of water vapors. In a large system there will also be a tangle of tubes to distribute the air and collect it again. The cold surface has two independent jobs to do: it is used to cool the air and it is also used to dehumidify, by condensing water from the air. This means that the air is cooled more than is necessary for temperature control, thus that it must be heated again afterwards. Air conditioning wastes energy. It also wastes space, because air has to be pumped around in quite large tubes, so that it makes a rushing noise. It does, nevertheless, generate a disturbing background noise if the room is otherwise quiet. There is worse news to come: air conditioning is spreading to more and more buildings in climates that we once thought were so mild that they would be immune.

2.3 Inverter Technology

Conventional air-conditioning or non-inverter type, operating at a fixed speed compressor. Total energy uses during the cooling and heating processes are fixed. When the set temperature to maintain the principle is 'start' and 'stop' or 'on' and 'off'. The emergence of new technology tools to produce a so-called 'inverter'. The use of inverter technology in improving the cooling air temperature and decrease in energy faster. (Source: www.thompson-cooling-faqs-what-daikin-inverter-technology).

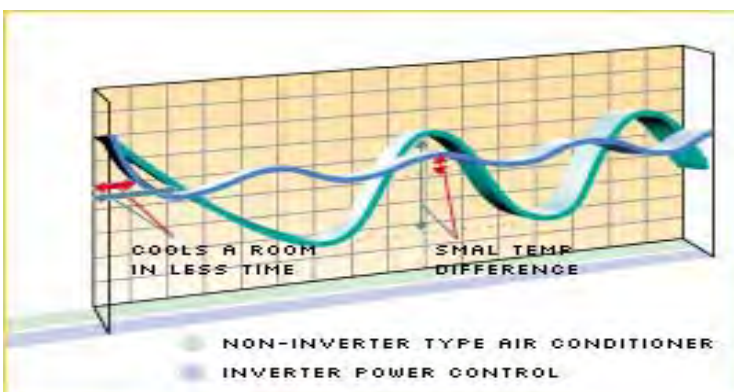

Figure 2.3: Inverter Quick Comfort

(Source: www.thompson-cooling-faqs-what-daikin-inverter-technology)

2.4 Inverter in Electrical

Inverter is a device that converts DC power from the AC current. Alternating current can be changed at any required voltage and frequency by using the right transformer, switches and control circuits. Inverter has no moving parts and used in various applications, from small switching power supplies in computers to large applications of high voltage power flows. Inverter is usually used to supply AC power from direct current, such as solar panels or batteries. The electrical inverter is a high-power electronic oscillator. It is so named because early mechanical AC to DC converters was made to work in reverse, and thus was "inverted", to convert DC to AC. (Source from www.wikipedia.com, "inverter in electrical").

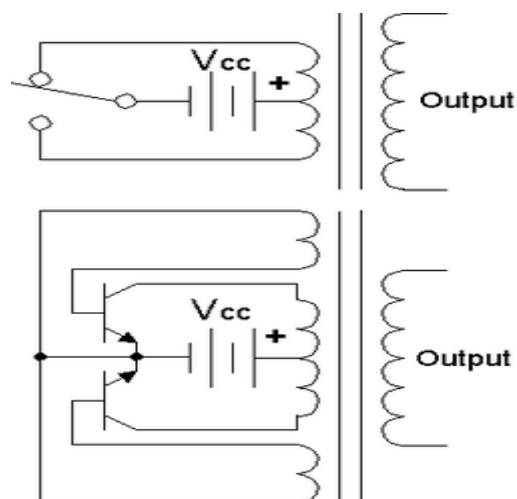

Figure 2.4: simple circuit with electromechanical switch and automatic equivalent
(Source: www.wikipedia.com, "inverter in electrical")

2.5 Inverter Control the Speed Compressor

According to P. Sarntichartsaka et al. (2006), inverter type air conditioner is known in the compressor speed control techniques, the benefits can provide savings or energy conservation and comfort.

2.6 Assessment of the thermal environment effects on human comfort and health for the development of novel air conditioning system in tropical region.

By Thammanoon Sookchaiya (2009) conduct a study determine the level of humidity and temperature in Thailand. By using an inverter and non-inverter air-conditioning. The results shows that by using an inverter type air conditioning system shows that the temperature in the room changing rapidly and the relative humidity can be controlled in the desired 50-60% compared with non-inverter. Energy consumption also showed that the type of inverter air conditioner is more efficient than non-inverter type, which lead to energy saving.

2.7 Payback Period

Payback period is probably the simplest method to see a greater investment project or idea. Payback period method focuses on the cost recovery period investment. Payback is the amount of time needed for capital budgeting projects to restore the initial payment.

$$\text{Payback period formula} = \frac{\text{Cost of Project}}{\text{Annual Cash Inflows}} \dots\dots\dots (1)$$

Payback period is the concept that all other things being equal, better investment returns is shorter. (Source: Engineering Economics Book, Fourth Edition).

2.8 Theoretical of Energy Consumption

Energy efficiency means using the minimum energy to accomplish the same work in the home or office. This means to reduce energy consumption as well as similar facilities. The air conditioner has a rating of energy efficiency (Energy Efficiency Ratio,

EER). EER is the energy conversion efficiency of the equipment, the value, the more efficient the equipment. EER of an air conditioner cooling capacity indicates the ratio of horsepower. Take from book, Efficiency Energy, Center for Education and Training in Renewable Energy and Energy Efficiency (www.ktak.gov.my).

Formula to determine the energy consumption

First, calculate the energy consumption in kWh:

$$\text{kWh} = \text{Power (unit watt)} \times \text{The number of hours of use (unit hour)} / 1000$$

Second, calculate the energy cost

$$\text{Energy cost} = \text{Energy (unit kWh)} \times \text{Tariff (unit RM/kWh)}$$

Tariff can be found by referring to Tenaga Nasional Berhad.

Tenaga Nasional Berhad has several categories of use a charge which the consumer was charged by the rates set by the tenaga nasional berhad. If the power consumption of 0 to 400 kwh, the first 200 kwh, the wear rate is 21.8 cents/kwh and if the next 200 kwh were rate was 34.5 cents/kwh.

2.9 Air-Conditioning System

According to Natural Resource Canada (2004), room air conditioners function in much the same way as refrigerators do – heat is extracted from the space that is being cooled and is conveyed outside of that space. A fan circulates room air through the evaporator, which contains low-pressure refrigerant (refer figure 2.9). Evaporation of the refrigerant cools the tubes and fins, extracting heat from the air and causing moisture in the air to condense on the evaporator's outer surface. The cooler, drier air is returned to the room, and the gaseous refrigerant leaving the evaporator is drawn into the compressor where mechanical compression raises its temperature and pressure. The hot, high-pressure refrigerant passes through the condenser, where it loses heat to outdoor air (which is blown over it with a second fan) and condenses. This high-pressure liquid