

THE STUDY OF TRANSMISSION FROM PLANAR TO SIW STRUCTURE

NOR SU'AIDAH BT SUPARMAN

**This Report Is Submitted In Partial Fulfillment Of Requirements For The
Bachelor Degree of Electronic Engineering (Industrial Electronic) With Honours**

Faculty of Electronic and Computer Engineering

Universiti Teknikal Malaysia Melaka

April 2011



UNIVERSITI TEKNIKAL MALAYSIA MELAKA
 FAKULTI KEJURUTERAAN ELEKTRONIK DAN KEJURUTERAAN KOMPUTER

**BORANG PENGESAHAN STATUS LAPORAN
 PROJEK SARJANA MUDA II**

Tajuk Projek Sesi Pengajian : THE STUDY OF TRANSMISSION FROM PLANAR TO SIW STRUCTURE

:

1	0	/	1	1
---	---	---	---	---

Saya **NOR SU'AIDAH BT SUPARMAN**

mengaku membenarkan Laporan Projek Sarjana Muda ini disimpan di Perpustakaan dengan syarat-syarat kegunaan seperti berikut:

1. Laporan adalah hakmilik Universiti Teknikal Malaysia Melaka.
2. Perpustakaan dibenarkan membuat salinan untuk tujuan pengajian sahaja.
3. Perpustakaan dibenarkan membuat salinan laporan ini sebagai bahan pertukaran antara institusi pengajian tinggi.
4. Sila tandakan () :

SULIT*

*(Mengandungi maklumat yang berdarjah keselamatan atau kepentingan Malaysia seperti yang termaktub di dalam AKTA RAHSIA RASMI 1972)

TERHAD**

** (Mengandungi maklumat terhad yang telah ditentukan oleh organisasi/badan di mana penyelidikan dijalankan)

TIDAK TERHAD

Disahkan oleh:

(TANDATANGAN PENULIS)

(COP DAN TANDATANGAN PENYELIA)

Alamat Tetap : NO.113, KG PT YOB,
 PT YA'ANI,
 83710 YONG PENG,
 JOHOR DARUL TAKZIM

Tarikh: 3TH MAY 2011

Tarikh: 3TH MAY 2011

“ I hereby declared that this report entitled The Study of Transmission From Planar To Substrate Integrated Waveguide is a result of my own work except for quoted that have been cited clearly in the references”

Signature :

Student : NOR SU'AIDAH BT SUPARMAN

Date : 3TH MAY 2011

“ I hereby declared that I have read this report and in my opinion this report is sufficient in term of the scope and quality for the award the Bachelor of Electronic Engineering (Industrial Electronic) With Honours”

Signature :

Supervisor : DR. BADRUL HISHAM BIN AHMAD

Date : 3TH MAY 2011

Specially dedicate to my beloved parent, En. Suparman Bin Hj Tahir and Pn. Wahidah Hj Ishak and also to my siblings who give the encouragement and support for me to completed this thesis. Not forgotten to my supervisor Dr. Badrul Hisham Bin Ahmad who gave me lot of guidance and advice throughout this project until successful. Thanks you very much to all of you.

ACKNOWLEDGEMENTS

First of all, I would like to thank to all who supporting me and give me all guidance for finish up all tasks assigned while completing this research report. A lot of thanks for Dr. Badrul Hisham B. Ahmad as my supervisor because give a chance to complete my project.

Last but not least to the Universiti Teknikal Malaysia Melaka (Utem), especially to all my friends, Adilah Abu Samah, Nurul Atiqah bt Ismail, Noor Azah bt Ab Halim, Siti Sabariah bt Sabri and Saiful who give me a lot of help no matter whether in work or in the preparation. Also thanks due to my father, Mr. Suparman Hj Tahir and my mother, Mrs. Wahidah Hj Ishak, and also my family members are also involved directly or indirectly during this project is made and when I completing this report.

ABSTRACT

This paper focuses on the study of the transmission from planar to SIW structure. The goals of this thesis are to research the various types of transition between microstrip lines to Substrate Integrated Waveguide (SIW) transmission lines. A few types of transition will be studied such as microstrip transition, coplanar transition and to compare its performance against the Substrate Integrated Waveguide (SIW) structure. Transitions between rectangular waveguides and planar circuits cannot be held without extra supporting structures. A better solution is a tapered transition which should be over as long a length as feasible. This introduces a slow transition from the circular cross-section to the rectangular cross-section. There is a very clear improvement in Return Loss when the transition is doubled in length.

In this research, the Substrate Integrated Waveguide (SIW) is design and simulated by using Advance Design System (ADS) software in order to characterize the return losses and insertion losses, and to achieve the losses same as theory. Subsequently, a prototype circuit is built to verify theoretical and simulations results.

Thus, the performance of the losses given can be graphically obtained, and try to achieve the better losses from these three types of transition.

ABSTRAK

Kajian penyelidikan ini tertumpu untuk penghantaran isyarat dari planar ke struktur *Substrate Integrated Waveguide (SIW)*. Tujuan dari tesis ini adalah untuk kajian pelbagai jenis penghantaran isyarat antara garis mikrostrip untuk *Substrate Integrated Waveguide (SIW)*. Beberapa jenis peralihan ataupun penghantaran akan dikaji seperti peralihan mikrostrip, peralihan *coplanar* dan untuk membandingkan prestasi terhadap struktur SIW. Peralihan antara gelombang pandu persegi panjang dan litar planar tidak dapat ditahan tanpa struktur penyokong tambahan. Penyelesaian yang lebih baik adalah peralihan meruncing yang harus lebih panjang dan sekata. Ini memperkenalkan peralihan lambat dari penampang silang bulatan untuk penampang persegi panjang. Peningkatan yang sangat jelas dalam penurunan kehilangan isyarat saat peralihan dua kali ganda penghantaran dan bentuk setiap jenis ataupun panjangnya.

Dalam kajian ini, *Substrate Integrated Waveguide (SIW)* adalah rekaan dan disimulasikan dengan menggunakan software *Advance Design System(ADS)* untuk mencirikan penurunan dan kemasukan kehilangan isyarat, dan untuk membuktikan setiap jenis kehilangan sama berbanding teori. Selanjutnya, rangkaian prototaip dibina untuk mengesahkan keputusan teori dan simulasi adalah betul.

Oleh sebab itu, prestasi kehilangan isyarat yang diberikan boleh diperolehi grafik, dan cuba untuk mencapai kerugian lebih baik dari tiga jenis peralihan.

TABLE OF CONTENT

CHAPTER		PAGE
	PROJECT TITLE	i
	DECLARATION	iii
	DEDICATION	v
	ACKNOWLEDGEMENT	vi
	ABSTRACT	vii
	ABSTRAK	viii
	TABLE OF CONTENT	ix
	LIST OF FIGURES	xi
	LIST OF TABLES	xiii
	LIST OF APPENDIX	xiv
I	INTRODUCTION	
	1.1 Background Project	1
	1.2 Problem Statement	2
	1.3 Objective	2
	1.4 Scope	2
	1.5 Project Outline	2
II	LITERATURE REVIEW	
	2.1 Introduction for Planar Circuit	4
	2.2 Substrate Integrated Waveguide	6
	2.3 Theory of MSL to SIW Transitions	7
	2.4 Modal Analysis of SIW	8
	2.5 Advantages of the SIW over microstrips	9

	2.6	TE modes	10
	2.7	Substrate Integrated Waveguide (SIW) Design	11
	2.8	Via holes	14
	2.9	Transition between planar circuit and SIW	15
III		METODOLOGY	
	3.1	Introduction	28
	3.2	Flowchart	30
	3.3	Project Methodology	31
	3.4	The Modelling Process	33
	3.5	Simulation using ADS software	34
	3.6	Fabrication	35
IV		RESULT AND DISCUSSION	
	4.1	Introduction	37
	4.2	Project Design Method	38
	4.3	Transition between SIW and microstrip	43
	4.4	Simulation	47
	4.5	Measurement	49
	4.6	Discussion	50
V		CONCLUSION AND FUTURE WORK	
	5.1	Conclusion	53
	5.2	Future Work	54

REFERENCES

LIST OF FIGURE

NO.OF FIGURE	TITLE	PAGE
1	Dominant modal electric field profiles	5
2	Transition between a microstrip line and SIW structure	6
3	Structure of SIW	8
4	Example for Rectangular Waveguide	10
5	(a) Air filled waveguide, (b) dielectric filled waveguide, (c) substrate integrated waveguide	11
6	Dimension definition of rectangular waveguide	12
7	Dimensions for DFW and SIW	13
8	SIW design with via holes	14
9	MSL to SIW transition with tapered microstrip feeding	16
10	Microstrip tapered to SIW structure	17
11	Equivalent topology for the microstrip-to-SIW transition	19
12	Transition between tapered microstrip and SIW	19
13	Optimum dimension for the microstrip-to-SIW discontinuity as a function of the permittivity ratio.	21
14	Return loss for several microstrip-to-SIW discontinuities sized using the proposed design equation (2.4).	21
15	Transition between a microstrip line and a SIW	23
16	TE ₁₀ surface currents distribution of the rectangular waveguide with slots on the narrow walls.	23
17	Dominant mode electric profiles	24
18	Transition between stepped impedance and SIW	24
19	Coplanar Waveguide	25
20	Field patterns in coplanar waveguide	25

21	Schematic view of the proposed transition of coplanar waveguide and rectangular waveguide integrated on the same substrate	26
22	Geometry of the CPW-to-rectangular waveguide transition	26
23	Return loss of tapered and stepped impedance transition	29
24	Step impedance types	29
25	Losses from step impedance types	30
26	Flowchart of Project	31
27	Flowchart for design SIW	34
28	Step Impedance transition design	34
29	Step for Etching Process	36
30	Configuration of the on-substrate integrated waveguide synthesized using metallized via-hole arrays	38
31	Rectangular waveguide	38
32	FR4 board for calculation	39
33	SIW design	42
34	Diameter and pitch	43
35	Line Calculation for Z_2	44
36	Line Calculation for Z_0	45
37	Line Calculation for Z_1	46
38	Simulation for Step impedance transition	47
39	Insertion losses and return losses	48
40	Fabrication for step impedance type	49
41	Measurement result	49

LIST OF TABLE

NO.OF TABLE	TITLE	PAGE
1	Properties of TE_{m_0} modes.	9
2	Comparison losses for each type from theory	50
3	Result for simulation and measurement from step Impedance type	51

CHAPTER I

INTRODUCTION

1.1 Background Project

The rapid growth, substrate integrated waveguide (SIW) has become the research hotspot in microwave circuit domain. SIW is fabricated with sidewalls consisting of periodic metallic via holes, largely preserving the advantages of both the conventional rectangular waveguide and micro-strip, like the high-Q factor, high power capacity, small size and the possibility of integration. Hence, many scholars had studied the propagation characteristics, energy leakage characteristics of SIW and the problem of the transition with micro-strip. This paper put forward a various types of SIW structure at the basic of these study, then analysis the propagation characteristics and the transition with micro-strip of this miniaturization structure. The miniaturization SIW is realized by conventional rectangular waveguide with array of via-holes.

1.2 Problem Statement

Substrate integrated waveguides (SIW), which inherit the advantages from traditional rectangular waveguides without their bulky configuration, aroused recently in low loss and high power planar applications. Transitions between rectangular waveguides and planar circuits cannot be held without extra supporting structures. A better solution is using the transition which should be over as long a length as feasible. This introduces a slow transition from the circular cross-section to the rectangular cross-section.

1.3 Objective:

- a) To determine the various type of transition between planar or microstrip lines to SIW transmission lines.
- b) To explore the transmission lines from planar to SIW structure.

1.4 Scope

Scopes of this project are making literature review which will survey on the journal, magazine, conference paper or textbook. During literature review all the information such as the theory and design of the various types of transition between planar or microstrip lines to SIW transmission lines. A few types of transition will be studied such as microstrip transition, coplanar transition and so on. The result work will use simulation tools and the result will compared with the theoretical result. Finally, comparison between types of transition from planar to SIW transmission lines will be made.

1.5 Project Outline

Chapter 1 consist the introduction part of the project such as the background, problem statement, objectives of the project and also the scopes of the project.

In chapter 2, it consist literature review about the design of the various types of transition between planar or microstrip lines to SIW transmission lines. This is including the history, an application, working principle and also it's about the concept and the importance of types. This is also explain about comparison between types of transition between planar or microstrip lines to SIW transmission lines.

Chapter 3 is basically explaining the methodology on simulation of the stepped impedance to SIW by using software ADS in order to characterize the good performance for any type's microstrip and to achieve the good transition between planar or microstrip lines to SIW transmission lines. During this, it will review about the method, mathematical calculation and design of the two type's transition.

In chapter 4, all the initial simulation results of the step impedance design and coplanar design is collected data are discussed it. This is including the graphs that have obtained during the simulation. It is started from using software ADS in order to characterize the good performance for any types microstrip, and to achieve the good transition between microstrip lines to SIW transmission lines.

In the last chapter, chapter 5 the conclusion has been made and for the future works, there is also recommendation added. The recommendation is added to give an opinion and also an improvement on how the future works should have done.

CHAPTER II

LITERATURE REVIEW

2.1 Introduction for Planar circuit

Recently, a new microwave components have developed with a planar circuit mounted in waveguide. Planar transmission line to waveguide transitions is very useful for circulators, multipliers and particularly for high frequency waveguide mixers [9]-[11]. Usually transitions from microstrip line to rectangular waveguide are made with three-dimensional (3-D) complex mounting structures. For rectangular waveguide can be used to design high components but requires complex transitions to integrated planar circuits. Several studies of transitions between microstrip line and rectangular waveguide have been reported [13]–[15].

Necessary for combining such planar structures and waveguide modules are often small transitions from rectangular waveguides to planar structures which have

a good electric performance and can easily be manufactured. However, typical integration schemes from rectangular waveguide with planar structure are bulky and usually require a precision machining process, which is difficult to achieve at millimeter-wave frequencies for mass production. The transitions always consist of two or more separate pieces that require judicious assembly, and a tuning mechanism is also generally essential. Furthermore, the planar substrate has to be cut into a specific shape. These constraints make integration difficult and costly [16].

A planar microstrip circuit often needs to be cut into a specific shape, which is hard to realize in the millimeter-wave range. Furthermore, rectangular-waveguide components are voluminous and expensive to manufacture, which inevitably make the planar/nonplanar integration bulky and costly [16]. A straightforward solution is to integrate the rectangular waveguide into the microstrip substrate. This will surely reduce the Q factor of the waveguide because of dielectric filling and volume reduction, but the entire circuit including planar circuit, transition and waveguide can be constructed using standard PCB or other planar processing techniques [17]. This planar circuit is very useful for low-cost mass production and high Q value.

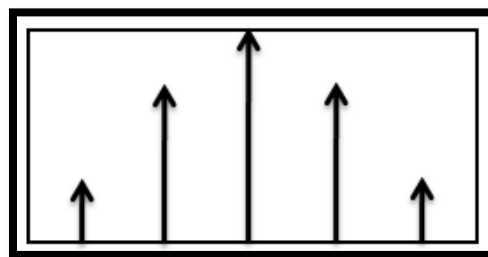

(a) Rectangular Waveguide

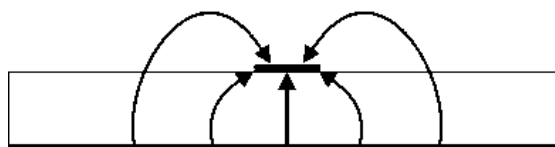

(b) Microstrip line

Figure 2.1: Dominant modal electric field profiles

(a) in rectangular waveguide

(b) in microstrip line and both fields are pointing in the same direction.[24]

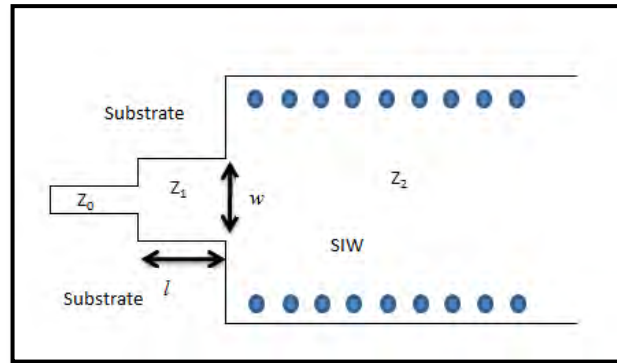

Figure 2.2: Transition between a microstrip line and SIW structure

Recently, the concept of the integrated rectangular waveguide has been proposed in which an artificial waveguide is synthesized and constructed with linear arrays of metallized via-holes or posts embedded in the same substrate used for the planar circuit. This waveguide can also be realized with complete metallized walls [1]. Several transitions have been proposed to excite the waveguide. In all these structures, the planar circuits, such as a microstrip line or coplanar waveguide, and the rectangular waveguide are built onto the same substrate and the transition is formed with a simple matching geometry between both structures. Judging from its electrical performance, the synthesized integrated waveguide is a good compromise between the air-filled rectangular waveguide and planar circuit [17].

2.2 Substrate Integrated Waveguide (SIW)

Substrate integrated waveguide (SIW) is a new form of transmission line that has been popularized in the past few years by some researchers. New transmission lines only come along once in a lifetime, so this is a big deal. A large variety of components such as couplers, detectors, isolators, attenuators and slot lines, are commercially available for various standard waveguide bands from 1 GHz to over 220GHz. Because of these trends towards miniaturization and integration, most microwave circuitry is currently manufactured using planar transmission lines such as microstrips transition, coplanar transition and so on. At

the same time, the waveguides needs many applications such as high power systems, millimetre wave systems and some precision test systems.

Transitions between rectangular waveguides and planar circuits cannot be held without extra supporting structures. Recently, SIWs were proposed as a replacement for miniaturized and light weighted applications. Nonetheless, such transitions can shed some light on the design of MSL to SIW transitions. SIW, as its name, can be easily integrated into the substrates of planar circuits, such as printed circuit boards (PCB) and low temperature co-fired ceramics (LTCC), with their standard fabrication processes. Compared with conventional rectangular waveguides, SIW has the advantage of low-cost, compact, and easy-integration with planar circuits. Although their quality factors cannot compete with those of traditional rectangular waveguides, they are more suitable in system integration. [24]

2.2 Theory of MSL to SIW Transitions

Rectangular waveguides are widely used in microwave systems for its high power handling ability, low radiation loss as well as low electromagnetic interference (EMI) to other circuit components. However they are also known with disadvantages such as bulky volume, heavy weight, high cost, and difficult integration with planar circuits. In addition, high precision process is required at millimeter wave frequencies. As a result, mass production is difficult for systems with rectangular waveguides. Laminated waveguides were first proposed in 1998 [Uchimura et al., 1998], where waveguides can be embedded in multilayer printed circuit boards with their side walls replaced by via fences. In 2001, concept of substrate integrated waveguides (SIW) was also proposed [Deslandes and Wu, 2001a; Deslandes and Wu, 2001b]. Waveguides embedded in single layer substrates are demonstrated with transitions to CPWs and MSLs. These kinds of waveguides can be easily integrated with other circuit components by a standard planar circuit fabrication process. Volume and weight are also significantly reduced. The structure and characteristic of SIWs will be introduced firstly in this section, followed by two kinds of excitation

structures and calculation of their input resistances. Construction of the equivalent circuit models where the input resistances are associated will also be presented.

2.4 Modal Analysis of SIW

Figure 2.1a shows the structure of an SIW, which is composed of the top and bottom metal planes of a substrate and two parallel via fences in the substrate. In order to replace the vertical metal walls, via pitch must be small enough. The vias must be shorted to both metal planes to provide vertical current paths, as shown in Fig. 2.1b, otherwise the propagation characteristics of SIW will be significantly degraded.[24]

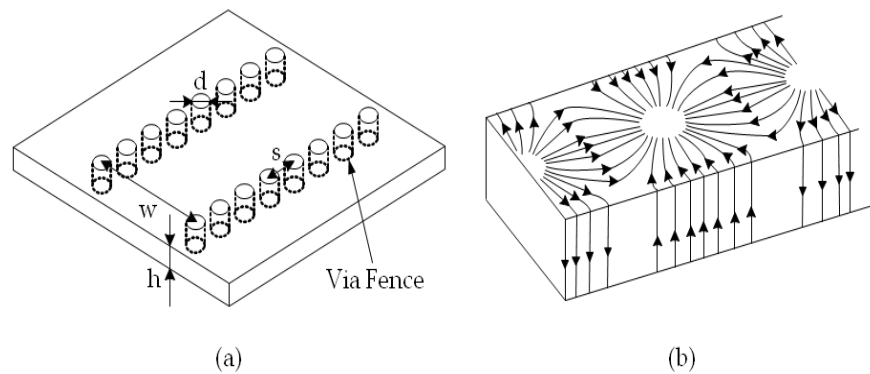

Figure 2.3: (a) Structure of SIW and (b) surface current for TE₁₀ mode.[24]

Since the vertical metal walls are replaced by via fences for the SIW structures, propagating modes of SIW are very close to, but not exactly the same as, those of the rectangular waveguides. This can be verified by checking the modal surface current patterns. Only patterns with solely vertical current distributed on the side wall survive in SIWs. For example, Fig. 2.1b shows the TE₁₀ mode surface current distribution of a rectangular waveguide. The current path will not be cut by the via fences, therefore TE₁₀ mode can be supported in an SIW. This holds for all TE_{m₀} modes since their current distributions on the side walls are similar. On the other hand, horizontal components of the surface current exist on the sidewalls for all TM

modes and TE_{mn} modes with nonzero n 's. These current paths will be cut in SIW structures, which results in radiation. Therefore we can conclude that only TE_{m0} modes exist in SIW structures. Properties of TE_{m0} modes are listed in Table 1 for later usage.[24]

PROPERTY	TE_{m0} MODES
Generating Function	$\psi_{m0} = \cos m\pi x / a$
Cut off Wave Number	$k_{c,m0} = \pi x / a$
Propagation constant	$\Gamma_{m0}^2 = k_{c,m0}^2 - k^2$, $k = \omega\sqrt{\mu\epsilon}$

Table 1. Properties of TE_{m0} modes.

2.5 Advantages of the SIW over microstrips

The SIW technique can be applied to applications other than microwave filters and antennas. The advantages of the SIW over conventional waveguides and microstrips are as follows:

- a) Lower loss compared to microstrips;
- b) 50% higher quality factor compared to microstrips;
- c) Higher power capability than microstrips;
- d) Simpler transition between the microstrip and the SIW;
- e) Lower manufacturing cost compared to waveguides;
- f) Highly reproducible results as the SIW is manufactured using the standard PCB process, which is cheap;
- g) Compact and small size compared to that of waveguides;
- h) Easy to connect to MIC and MMIC devices.

2.6 TE modes

We will first develop an extremely interesting property of EM waves that propagate in homogeneous waveguides. This will lead to the concept of modes and their classification as

- Transverse Electric and Magnetic (TEM)
- Transverse Electric (TE)
- Transverse Magnetic (TM)

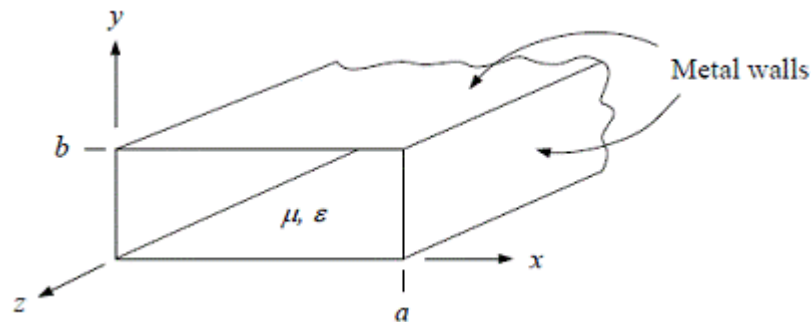

Figure 2.4 : Example for Rectangular Waveguide

Consequently, EM waves will propagate only when the frequency is large enough since there is no TEM mode. A transverse electric (TE) wave has $E_z = 0$ and $H_z = 0$. Rectangular, circular, elliptical, and all hollow, metallic waveguides cannot support TEM waves. It can be shown that at least two separate conductors are required for TEM waves. Examples of waveguides that will allow TEM modes include coaxial cable, parallel plate waveguide, stripline, and microstrip. The cut off frequencies for TE modes in a rectangular waveguide are determined from (12) with $\beta = 0$ to be [24]

$$f_{c,mn} = \frac{1}{2\pi\sqrt{\mu_r \epsilon_r}} \sqrt{\left(\frac{m\pi}{a}\right)^2 + \left(\frac{n\pi}{b}\right)^2} \quad (2.1)$$

In other words, these are the frequencies where $\beta_{mn} = 0$ and wave propagation begins when the frequency slightly exceeds $f_{c,mn}$. For an X-band rectangular waveguide, the cross-sectional dimensions are $a = 2.286$ cm and $b = 1.016$ cm. In the X-band region, only the TE_{10} mode can propagate in the waveguide regardless of how it is excited.

2.7 Substrate Integrated Waveguide (SIW) Design

Substrate integrated waveguide (SIW) [1], a low profile type of waveguide realized on substrate, has become more and more popular in recent years. The SIW circuits features merits of low-loss, low radiation, small size, and easy fabrications. In many cases, SIW can completely replace the rectangular waveguide for any circuit functions. Thus, we can anticipate that the hybrid design of planar structures such as microstrip lines, CPW lines, SIW with the conventional waveguides in microwave/millimeter-wave circuits/systems could be unavoidable. Therefore, transitions between various types of transmission lines are necessary. So far, transitions between different types of transmission lines have well been studied.

In high frequency applications, microstrip devices are not efficient, and because wavelength at high frequencies are small, microstrip device manufacturing requires very tight tolerances. At high frequencies waveguide devices are preferred; however their manufacturing process is difficult. SIW is a transition between microstrip and dielectric-filled waveguide (DFW). Dielectric filled waveguide is converted to substrate integrated waveguide (SIW) by the help of vias for the side walls of the waveguide.[13]

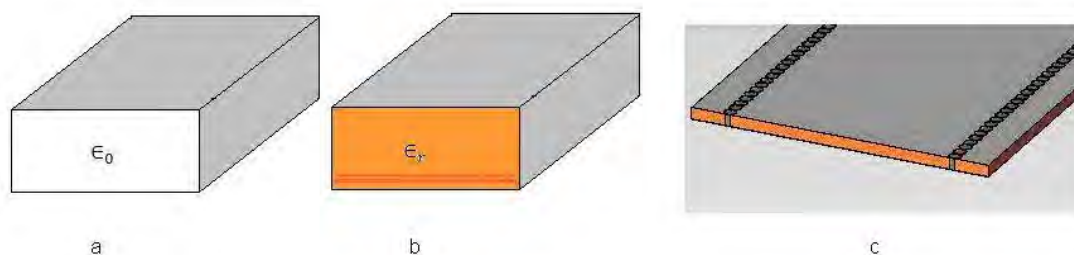

Figure 2.5 : (a) Air filled waveguide, (b) dielectric filled waveguide, (c) substrate integrated waveguide

Because there are vias at the sidewalls, transverse magnetic (TM) modes do not exist, TE_{10} therefore is the dominant mode. There are many articles for designing substrate integrated waveguides, however there are missing parts in many of them, they just