

# SMART HOME SECURITY SYSTEM USING MICROCONTROLLER

RUHILHAYATI BINTI MAHAMAD

This report is submitted in partial fulfilment of requirement for the award of Bachelor Electronic Engineering (Electronic Telecommunication) with Honours.

Faculty of Electronic and Computer Engineering  
Universiti Teknikal Malaysia melaka

April 2010



**UNIVERSITI TEKNIKAL MALAYSIA MELAKA**  
**FAKULTI KEJURUTERAAN ELEKTRONIK DAN KEJURUTERAAN KOMPUTER**

**BORANG PENGESAHAN STATUS LAPORAN**  
**PROJEK SARJANA MUDA II**

**Tajuk Projek** : SMART HOME SECURITY SYSTEM USING  
**MICROCONTROLLER**  
**Sesi Pengajian** : 

2007	/	2010
------	---	------

Saya **RUHILHAYATI BINTI MAHAMAD**

(HURUF BESAR)

mengaku membenarkan Laporan Projek Sarjana Muda ini disimpan di Perpustakaan dengan syarat-syarat kegunaan seperti berikut:

1. Laporan adalah hakmilik Universiti Teknikal Malaysia Melaka.
2. Perpustakaan dibenarkan membuat salinan untuk tujuan pengajian sahaja.
3. Perpustakaan dibenarkan membuat salinan laporan ini sebagai bahan pertukaran antara institusi pengajian tinggi.
4. Sila tandakan ( √ ) :

**SULIT\***

\*(Mengandungi maklumat yang berdarjah keselamatan atau kepentingan Malaysia seperti yang termaktub di dalam AKTA RAHSIA RASMI 1972)

**TERHAD\*\***

\*\* (Mengandungi maklumat terhad yang telah ditentukan oleh organisasi/badan di mana penyelidikan dijalankan)

**TIDAK TERHAD**

Disahkan oleh:

(TANDATANGAN PENULIS)

(COP DAN TANDATANGAN PENYELIA)

**MURHALA IRDAWATY BT HASSAN**  
 Pensyarah  
 Fakulti Kejuruteraan Elektronik Dan Kejuruteraan Komputer  
 Universiti Teknikal Malaysia Melaka (UTeM)  
 Karung Berkunci No 1752  
 Pejabat Pos Durian Tunggal  
 76109 Durian Tunggal, Melaka

Tarikh: 29 APRIL 2010

Tarikh: 29 APRIL 2010

“I hereby declare that this report is result of my own effort except for works that have been cited clearly in the references.”

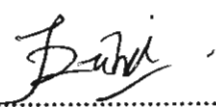
Signature :  .....

Name : RUHILHAYATI BINTI MAHAMAD

Date : 29 APRIL 2010

“I hereby declare that I have read this report and in my opinion this report is sufficient in terms of scope and quality for the award of Bachelor of Electronic Engineering (Electronic Telecommunication) with Honours”



Signature : .....

Supervisor's Name : MADAM NURMALIA IRDAWATY BT HASSAN

Date : 29 APRIL 2010

**NURMALIA IRDAWATY BT HASSAN**  
Pensyarah  
Fakulti Kejuruteraan Elektronik Dan Kejuruteraan Komputer  
Universiti Teknikal Malaysia Melaka (UTeM)  
Kerang Berkunci No 1752  
Pejabat Pos Durian Tunggal  
76100 Durian Tunggal, Melaka

## ACKNOWLEDGEMENTS

First of all, I am most grateful to Almighty ALLAH s.w.t. for blessing me with good health and ideas in completing this research successfully.

First of all, I would like to thank Allah for HIS firm hands in guiding me in the course of completing this thesis writing. Alhamdulillah.

I would like to show my highest gratitude to my supervisor, Madam Nurmala Irdawaty Binti Hassan for his invaluable support, patient, assistance and especially his encouragement to this project. I truly have learnt a lot and all this would not be without his guidance.

I also would like to thank all my fellow friends for their contribution in giving me a moral support throughout my project development period. Last but not least, to all my beloved family members who were always, stand by my side to encourage, advice, comfort, cherish, and support me during this entire project.

Lastly, I really appreciate to have this responsibility to finish this project. This task has taught a lot of lesson and knowledge which is much valuable for me in the future.

## **ABSTRACT**

This project focuses on the programming of microcontrollers using a high level language. The PIC family of microcontrollers is chosen as the target microcontroller because of the low power consumption which made this microcontroller popular in portable application. This project entitles Security System provides security to the house owner from any intruders or any form of robbery by automatically activating the alarm and emergency light and also display the situation by LCD connected to the microcontroller device. Through an alarm and emergency light microcontroller unit can immediately advise house owners that the house is being robbed or an intruder has illegally trespassed their respective home.

## CONTENTS

CHAPTER	TITLE	PAGE
	<b>PROJECT TITLE</b>	<b>i</b>
	<b>STATUS REPORT FORM</b>	<b>ii</b>
	<b>STUDENT DECLARATION</b>	<b>iii</b>
	<b>SUPERVISOR DECLARATION</b>	<b>iv</b>
	<b>ACKNOWLEDGEMENT</b>	<b>v</b>
	<b>ABSTRACT</b>	<b>vi</b>
	<b>ABSTRAK</b>	<b>vii</b>
	<b>CONTENTS</b>	<b>viii</b>
	<b>LIST OF FIGURE</b>	<b>xi</b>
	<b>LIST OF TABLE</b>	<b>xiii</b>
<b>I</b>	<b>INTRODUCTION</b>	
	1.1 Project Background	1
	1.2 Project Objective	4
	1.3 Problem Statement	4
	1.4 Scope of Project	5
	1.5 Signification of the project	5
	1.6 Report Structure	5
<b>II</b>	<b>LITERATURE REVIEW</b>	
	2.1 Block Diagram	7
	2.2 Power Supply Circuit	8

2.3	Microcontroller	
2.3.1	PIC 16F877	9
2.3.2	Memory	10
2.3.3	Flash Program Memory	11
2.3.4	EEPROM Data Memory	12
2.3.5	Data RAM (SRAM)	12
2.4	Relay	12
2.4.1	Relay application	14
2.5	Sensor	15
2.5.1	Magnetic sensor	16
2.5.2	Vibration sensor	17
2.5.3	Motion sensor	18
2.6	Uninterruptible power supply	19
2.7	Liquid crystal display	21
2.8	PIC C Compiler	22

### **III                    METHODOLOGY**

3.1	System Overview.	24
3.2	Overall Project Flow	25
3.3	Circuit Method	26
3.3.1	Process of Circuit Construction	28
	3.3.1.1 Design circuit using Proteus	29
	3.3.1.2 Simulation and Analysis	30
3.4	Find the Component	32
3.5	PCB Fabrication	
3.5.1	Design Circuit Using Proteus 99 SE	34
	3.5.1.2 PCB drilling	39
	3.5.1.3 Solder onto a PCB	40
3.6	Model Construction	41



3.7	Hardware Product	43
-----	------------------	----

#### **IV RESULT AND DISCUSSION**

4.1	Result	44
	4.11 Hardware Result.	44
	4.12 Overall Circuit	49
4.2	Discussion	51

#### **V CONCLUSION AND RECOMMENDATION**

5.1	Conclusion	52
5.2	Recommendation	53

	<b>REFERENCES</b>	54
--	-------------------	----

**APPENDIX A**

**APPENDIX B**

## LIST OF FIGURE

NO	TITLE	PAGE
1.1	Flow chart for overall system.	2
1.2	Flow of the system.	3
2.1	Executive Summary of the Project.	8
2.2	Voltage Regulator 5V Circuit	9
2.3	Pin configuration and symbol for voltage regulator 7805.	9
2.4	PIC 16 F 877	11
2.5	PIC 16F877 Program Memory Map and Stack.	12
2.6	SPDT Relay.	15
2.7	Magnetic Contact.	16
2.8	Installation Magnetic contact on the door or windows.	16
2.9	Magnetic Contact with NC and NO contact.	16
2.10	Vibration sensor.	18
2.11	Motion sensor.	20
2.12	Standby UPS.	20
2.13	Timing Diagram.	21
2.14	DDRAM address for display location.	22
3.1	Layout's Overall Design Process	25
3.2	Flowchart of methodology	27
3.3	Circuits construction process	28
3.4	Software	29
3.5	Overall circuit using Proteus	29
3.6	Simulation of Power Supply	31
3.7	Output of voltage LM7805	31
3.8	Proteus design for PIC	
3.9	Proteus Design	34
3.10	Top View for main board	35

3.11	Top View for Interruptible Power supply	35
3.12	Bottom View for main board	36
3.13	Bottom View for Interruptible Power supply	36
3.14	Ultra-Violet Ray	37
3.15	Developer Process	37
3.16	Cleaning with water	37
3.17	Etching Process	38
3.18	Flow the Stripper on PCB	38
3.19	Drilling Process	39
3.20	Soldered PCB	40
3.21	Top View	41
3.22	Front View	41
3.22	Side View	41
3.23	Roofs view on top	41
3.24	Roofs view on top	42
3.25	Overall side view of house	42
3.26	Complete model	42
3.27	Master board (microcontroller installation)	43
3.28	Interruptible power supply (EPS)	45
4.1	Welcome Home	
4.2	Enable sensor	45
4.3	Password	46
4.4	Disable sensor	46
4.5	Enter old password	47
4.6	Enter New Password	47
4.7	Password Changed Success	48
4.8	Zone 2 error	49
4.9	Power supply circuit	49

4.10 Overall system circuit.	50
------------------------------	----

## LIST OF TABLE

3.1 Voltage Measurement	
3.2 Component list	33

## **CHAPTER I**

### **INTRODUCTION**

This chapter will briefly discuss on the project overview. The objective, scope, and thesis outline will be presented in this chapter.

#### **1.1 Project Background**

This project focuses on the programming of microcontrollers using a high-level language. The PIC family of microcontrollers is chosen as the target microcontroller because of the low power consumption which made this microcontroller popular in portable application [1]. This project is to build an integrated security system. When there is an attempt of break-in the security system will sound and alert. Each sensor can be enabled or disabled by the user. The system is fully digital and also be fully customized. It incorporated a 16x2 LCD display with a 4x4 keypad. LCD will display the system status if anything happen. The microcontroller (PIC) will be programmed in order to control the system practical. The system is very practical because user can be enabling or disable the system by using the password. This system also use uninterruptible power supply as a battery backup to provides emergency power.

This system not just can be used in home environment but it also can be practically used in a business environment too. This security system can be said as friendly and multiple used because it can monitor the surround to not only protect our properties but also our lives. Certain security systems can be set to literally cover all floors and doors inside and outside of the home .This project entitles Security and Control System provides security to the house owner from any intruders or any form of robbery by automatically activating the alarm and can immediately advise house owners that the house is being robbed or an intruder has illegally trespassed their respective home.

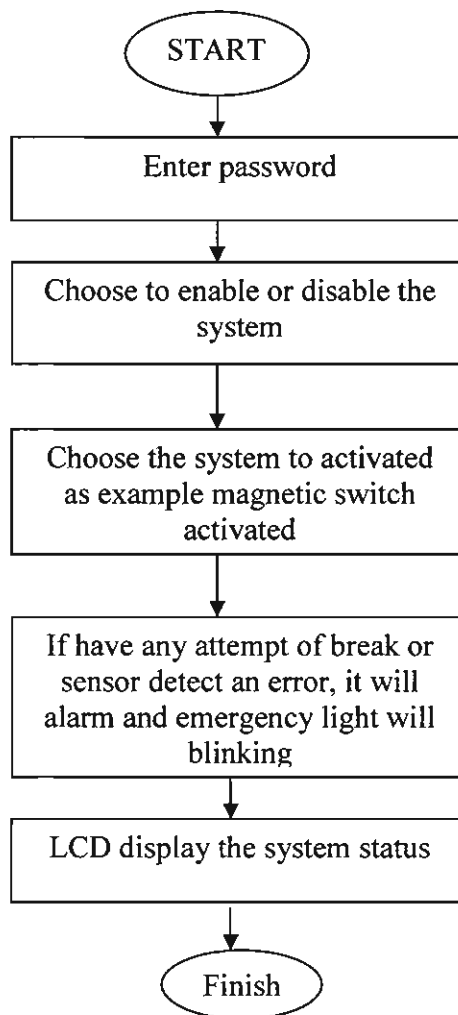

Figure 1.1: Flow chart for overall system.

Figure above explained the processes which are:

- i. The process starts when the user switches on the system.
- ii. After that, user needs to insert the correct password and user can choose which one of the sensor that can be activated or not.
- iii. Then, the information would be transmitted to microprocessor as a main part of the system if sensor detects anything wrong.
- iv. After receiving the information, alarm will sound and emergency light will flashing or blinking to immediately inform and advise house owners that the house is being robbed or an intruder has illegally trespassed their respective home.
- v. Then LCD will display the situation status.

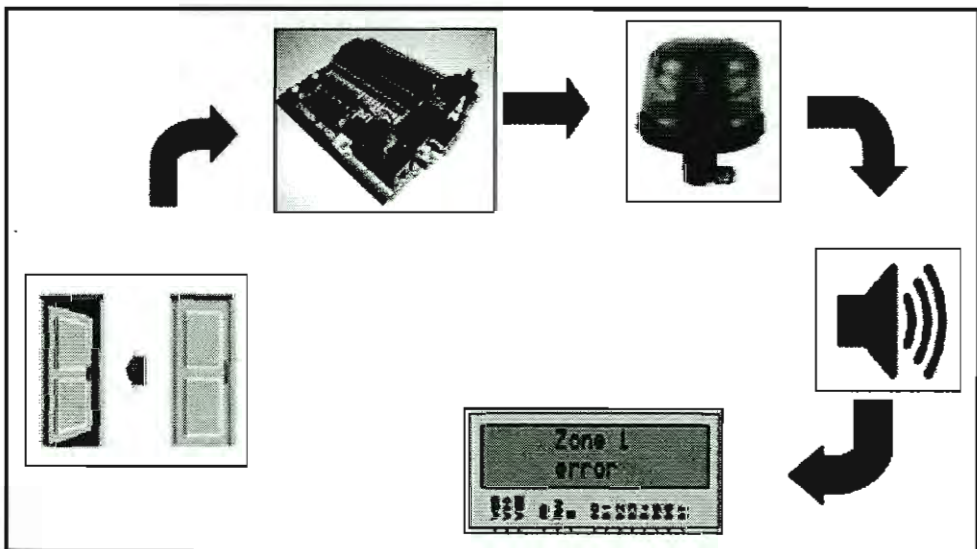

Figure 1.2: Flow of the system.

## 1.2 OBJECTIVES

The main objective of this project is to design and develop a security system for house owner that is capable of monitoring any intruders and other emergency situation by alarming the house owners and display the situation by using LCD. The objective can be summarized as below:

- i. To use PIC as a main remote device.
- ii. To build a security system that can increase the safety level, health and welfare of the public.
- iii. To reduce the amount of stolen not only at home but also at business environment
- iv. To rapidly detect unwanted visitor or thief.
- v. To design multiple security in one system
- vi. To design modern technology, high security
- vii. To enhance the knowledge on PIC
- viii. Program the PIC as interfacing.
- ix. Integrated with schematic and analysis.

## 1.3 PROBLEM STATEMENT

The conventional method that is usually been used by home owner is user always worried about their home especially while they are not at home. The problems which often occurred due to this method are:

- i. The number of stolen increase in our country because lack the control and attention by owner.
- ii. Unwanted visitor or thief always disturbs our life.



## 1.4 SCOPES

This project is subjected to several scope and limitations that are narrowed down to the study. There are a few scopes and guidelines listed to ensure the project is conducted within its intended boundary. This is to ensure the project is heading in the right direction to achieve its intended objectives. The objectives are:

- i. Research study on the Programmable Intelligence Computer, PIC16F87A microcontroller and the control system of the circuit.
- ii. To acquire the each sensor that use in this project.
- iii. To design circuitry for the overall system
- iv. To develop the program that can integrate and control the overall system.

## 1.5 SIGNIFICATION OF THE PROJECT

- i. Improves the quality of security system.
- ii. Save cost.

## 1.6 REPORT STRUCTURE

Chapter one briefly introduces the overall of the project title Smart Home Security system using microcontroller. The introduction consists of overview, objective, problem statement, scope of work, methodology and structure report. Meanwhile chapter two discuss about the background of study related to security system. Literature review will produce overall structure of the security system which shows the relationship between project research and theoretical concept.

Chapter three will explain about the project methodology. Project methodology give details about the method used to solve the problem to complete the project. The method used such as collecting data method, process and analysis data method, modelling and etc.

Chapter four consists of result and discussion of the project, finding and analysis throughout the research and project development.

Lastly, chapter five is the project conclusion. This chapter rounds up the attained achievement of the whole project and reserves suggestions for possible future researches.

## **CHAPTER II**

### **LITERATURE REVIEW**

This project is divided into few parts; consist of microcontroller, electronic keypad, sensor and LCD display. The division is for easy development and implementation. Each part can be test and work independently. At the end of the project, all of the parts will be connected together to form the complete security system. An approach to complete this project will be discussed in this chapter. It consists of the hardware part and software part. Figure 2.1 shows the executive summary of the project.

#### **2.1 Block Diagram**

Figure 2.1 explains the block diagram of the Smart Security System. When there is an attempt of break-in or any possible unwanted visitor or thief, the security system will sound and alert. Each sensor can be enabled or disabled by the user, beside alarm frequency also can be chosen by the users. The system is fully digital and also be fully customized. It incorporated a 16x2 LCD display with a 4x4 keypad. The microcontroller (PIC) will be programmed in order to control the system practical.

The system is very practical because user can be enabling or disable the system by using the password. This system not just can be used in home environment but it also can be practically used in a business environment too. This security system can be said as friendly and multiple used because it can monitor the surround to not only protect our properties but also our lives. Certain security systems can be set to literally cover all floors and doors inside and outside of the home.

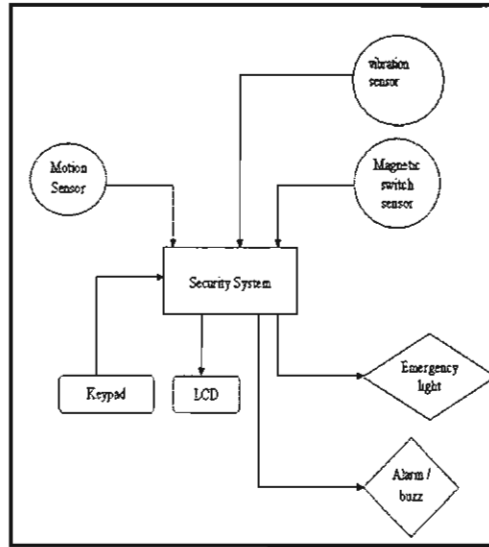

Figure 2.1: Executive Summary of the Project.

## 2.2 Power Supply Circuit

For this project, I used 5V voltage regulator to achieve desired voltage. Figure 2.2 shows schematic for power supply that are used in this project.

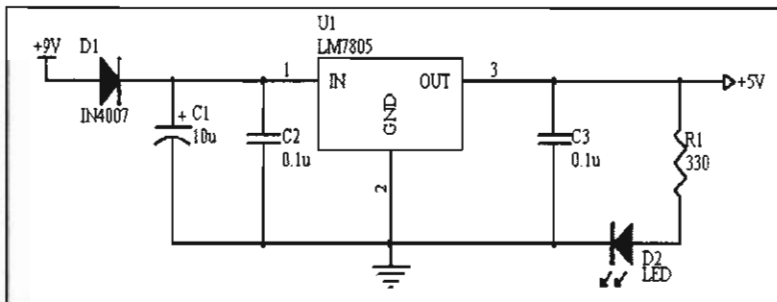

Figure 2.2: Voltage Regulator 5V Circuit

The voltage regulator circuit functions as the power supply for the microcontroller circuit. The construction of the voltage regulator circuit consists of voltage regulator and capacitors. Power for the circuit is derived from a 12V DC power supply and regulated down to 5V by the 7805. Reverse polarity will destroy the regulator almost instantly [1].

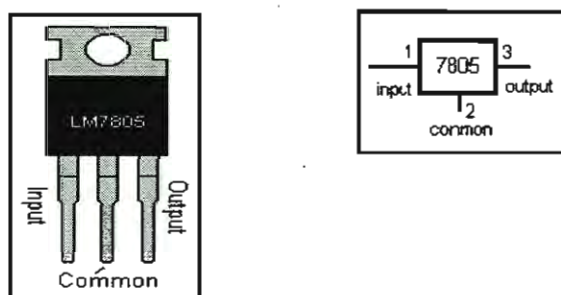

Figure 2.3: Pin configuration and symbol for voltage regulator 7805

From the schematic diagram of circuit, the 0.1 $\mu$ F capacitor eliminates any high frequency pulses that could otherwise interfere with the operation of the regulator. Capacitor 0.1 $\mu$ F by passes the supply and helps stabilise the regulator while 470 $\mu$ F capacitor, helps filter the power from the power supply. Figure 2.3 shows the pin configuration for voltage regulator.

## 2.3 Microcontroller (PIC)

### 2.3.1 PIC 16F877

The PIC 16F877 is a microcontroller that has many features in a 40-pin DIP package. Microcontroller will be used as driver for the LCD display. Currently known PIC will be PIC 16 F 877 manufactured by MICROCHIP. Market available LCD driver chip may be used to replace PIC. Aside from programming, other characteristics of the PIC MCU have to be known in order to enable the MCU to function properly.

An important aspect is the interference caused by the PIC itself because of the clocking set for it to function. It will cause interface. Thus a shielding procedure is needed such as to cover the body of PIC with EM conductor shielding tape or by placing ground plane around the PIC in PCB circuit board design. Figure below is the condition of a PIC 16 F 877 shielded with a shielding tape [2].

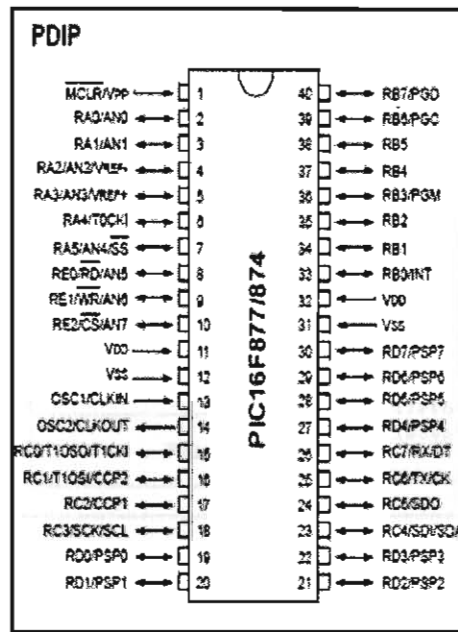

Figure 2.4: PIC 16 F 877

### 2.3.2 Memory

The PIC 16F877 microcontrollers carry a large memory array, which can be divided into three types:

- Flash Program Memory
- EEPROM Data Memory
- Data RAM

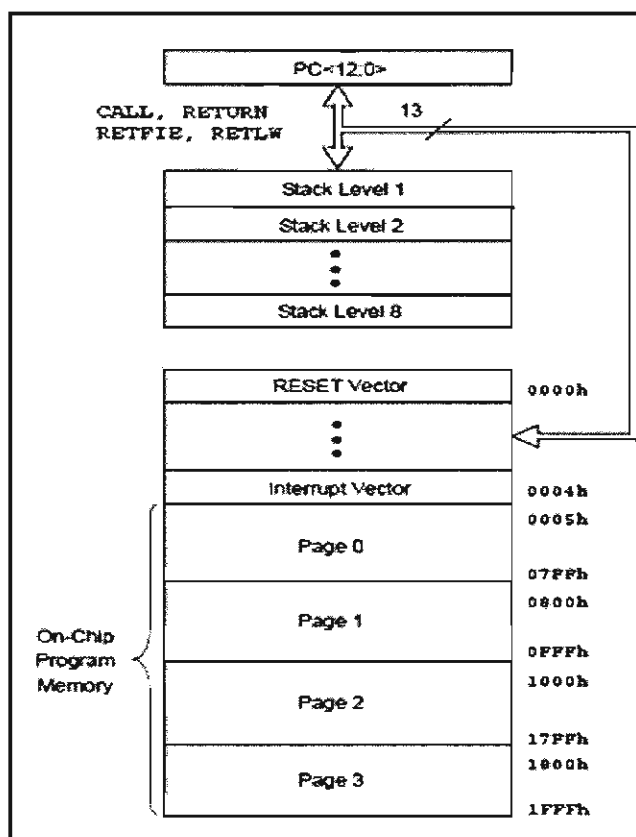

Figure 2.5: PIC 16F877 Program Memory Map and Stack

### 2.3.3 Flash Program Memory

The entire program memory is made up of flash array. The PIC 16F877 has 8K bytes of flash program memory. Every single byte of flash program memory can be erased and reprogrammed. This can be done either in a conventional PIC programmer such as economical PICSTART units available from Microchip or can even be done during an application. And all this can be done by a small user code resident in program memory, without requiring any external higher programming voltage this level of flexibility is very beneficial in today fast pace development, where product updates and modifications are routinely carried out in the field [3].

### 2.3.4 EEPROM Data Memory

EEPROM data memory is suitable for multiple erase and writes operation. This is normally suitable for storing coefficient data, which may be programmed from time to time. The EEPROM data memory is not mapped in register file address space, but is mapped differently, and is also accessed through a set of SFRs. PIC 16F877 contain 256 byte of EEPROM data memory.

### 2.3.5 Data RAM (SRAM)

RAM availability in microcontroller is increasing steadily and PIC 16Fxx series is no exception. PIC 16F877 contains 368 bytes of SRAM. The Data Memory is partitioned into 4 banks of 128 bytes each. The lower section (00 to 20H) of each of these banks is devoted to special function registers, and the balance is left for Data RAM. This device has an interesting feature that the top 16 bytes of each bank are used to address the same data memory space (70 to 7FH). This reduces the need for bank switching (a real nuisance).

## 2.4 RELAY

A simple electromagnetic relay, such as the one taken from a car in the first picture, is an adaptation of an electromagnet. It consists of a coil of wire surrounding a soft iron core, an iron yoke, which provides a low reluctance path for magnetic flux, a moveable iron armature, and a set, or sets, of contact; two in the relay pictured. The armatures is hinged to the yoke and mechanically linked to a moving contact or contacts. It is held in place by a spring so that when the relay is de energized there is an air gap in the magnetic circuit. In this condition, one of the two sets of contacts in the relay pictured is closed, and the other set is open. Other relay may have more or fewer sets of contact depending on their function.