



**UNIVERSITI TEKNIKAL MALAYSIA MELAKA**

**PROGRAMMABLE PICK AND PLACE ROBOT ARM FOR AGV  
SYSTEM**

This report submitted in accordance with requirement of the Universiti Teknikal Malaysia Melaka (UTeM) for the Bachelor Degree of Manufacturing Engineering (Robotic and Automation) with Honours.

by

**LEE WAI KIONG**

FACULTY OF MANUFACTURING ENGINEERING

2008



## UNIVERSITI TEKNIKAL MALAYSIA MELAKA

### BORANG PENGESAHAN STATUS LAPORAN PSM

**TAJUK:** Programmable Pick and Place Robotic Arm for AGV System

**SESI PENGAJIAN:** 2008/2009 Semester 2

Saya **Lee Wai Kiong**

mengaku membenarkan laporan PSM ini disimpan di Perpustakaan Universiti Teknikal Malaysia Melaka (UTeM) dengan syarat-syarat kegunaan seperti berikut:

1. Laporan PSM adalah hak milik Universiti Teknikal Malaysia Melaka dan penulis.
2. Perpustakaan Universiti Teknikal Malaysia Melaka dibenarkan membuat salinan untuk tujuan pengajian sahaja dengan izin penulis.
3. Perpustakaan dibenarkan membuat salinan laporan PSM / tesis ini sebagai bahan pertukaran antara institusi pengajian tinggi.
4. **\*Sila tandakan (√)**

**SULIT**

(Mengandungi maklumat yang berdarjah keselamatan atau kepentingan Malaysia yang termaktub di dalam AKTA RAHSIA RASMI 1972)

**TERHAD**

(Mengandungi maklumat TERHAD yang telah ditentukan oleh organisasi/badan di mana penyelidikan dijalankan)

**TIDAK TERHAD**

Disahkan oleh:

\_\_\_\_\_

\_\_\_\_\_

(TANDATANGAN PENULIS)

(TANDATANGAN PENYELIA)

Alamat Tetap:  
4, Jalan Tembaga Kuning 2,  
Taman Sri Skudai,  
81300, Skudai, Johor.

Cop Rasmi:

Tarikh: \_\_\_\_\_

Tarikh: \_\_\_\_\_

\* Jika laporan PSM ini SULIT atau TERHAD, sila lampirkan surat daripada pihak organisasi berkenaan dengan menyatakan sekali sebab dan tempoh tesis ini perlu dikelaskan sebagai SULIT atau TERHAD.

## DECLARATION

I hereby, declared this report entitled “Programmable Pick and Place Robot Arm for AGV System” is the result of my own research except as cited in references.

Signature : .....

Author's Name : .....

Date : .....

## **APPROVAL**

This report is submitted to the Faculty of Manufacturing Engineering of UTeM as a partial fulfillment of the requirements for degree of Bachelor of Manufacturing Engineering (Robotic & Automation) with Honours. The member of the supervisory committee is as follow:

(Signature of Supervisor)

.....

(Official Stamp of Supervisor)

## **ABSTRACT**

As the rise of the robotic technology toward the human life, the manufacturing sector has come to more depend on this technology where it provides a lot of benefits for the human. The field of Robotics and Control is both interdisciplinary and multidisciplinary as robot are amazingly complex systems comprising mechanical, electrical and electronics hardware and software systems and issues germane to all these. This report will then present the research of pick and place robotic arm that will attach on an Automated Guided Cart where it will provide aid to load and unload components for the industry assembly line. This project report will then simply introduce the robot arm and some problem that current manufacturing industry has facing. Then, it will also show the product of the robot arm that being designed, progress, and fabricated in order to achieve the primary objective of the robot arm. Moreover, the robot arm will then be tested by a designed experiment in order to obtain the efficiency data that will provide help to improve the robot arm and the AGV system. The study of the result will be showed at this report and some explanation of the robot arm operation will provided in order to guide the reader understand them. This research was done in order to maintain the production rate while reduce the human workforce cost demand at the industry. The development was come out based on the experience at the practical industry where the product transportation was still mainly on human workforce. Thus, this has provided the study on the cost efficiency by apply the robotic system in industry.

## ABSTRAK

Kebangkitan teknologi robot terhadap kehidupan manusia, sektor perkilangan telah tiba untuk lebih bersandarkan teknologi ini di mana ia menyediakan banyak faedah untuk manusia. Kedua-dua bidang *Robotics* dan *Control* merupakan antara disiplin dan pelbagai disiplin sebagai robot adalah sistem-sistem yang kompleks mengandungi mekanikal, elektrik dan elektronik perkakasan, sistem-sistem perisian dan isu-isu berkait untuk keseluruhan ini. Laporan ini akan membentangkan penyelidikan terhadap cara angkat dan letak oleh tangan robot yang pasang pada Automated Guided Cart di mana ia akan menyediakan bantuan untuk mengangkat dan meletakkan komponen-komponen untuk talian pemasangan industri. Tujuan laporan projek ini hanya memperkenalkan tangan robot dan sedikit masalah yang akan di hadapi oleh industri pembuatan pada masa kini. Kemudian, laporan ini akan menunjukkan hasil tangan robot yang telah dipolakan, membangun, dan dibuat supaya mencapai matlamat utama tangan robot. Tambahan pula, tangan robot akan kemudiannya diuji pada satu eksperimen yang disediakan untuk mendapatkan data kecekapan yang akan menyediakan membantu untuk meningkatkan tangan robot dan sistem AGV. Analisis terhadap hasil kajian akan ditunjukkan di laporan ini dan beberapa penjelasan mengenai operasi tangan robot akan dinyatakan untuk pemahaman pembaca. Penyelidikan ini telah dilakukan untuk mengekalkan kadar pengeluaran serta mengurangkan kos tenaga kerja manusia permintaan di industri. Ciptaan tangan robot ini adalah berdasarkan berpengalaman yang diperolehi di industri praktikal. Kebanyakan pengangkutan produk adalah masih berpandu kepada tenaga kerja manusia. Oleh itu, ini telah menyediakan kajian ke atas kecekapan kos supaya memohon sistem robot tersebut dalam industri.

## ACKNOWLEDGEMENTS

First, I want to thanks to the Faculty of Manufacturing Engineering where they have provide this chance of research for me. Then, I will like to thanks to Mr. Sivarao a/l Subramonian that have been keep provide and update the important information to me when conducting this PSM report. Then, I would like to thanks for the Mr. Lokman bin Abdullah that provide me this chance to conduct this research and project and also guide me to finish the PSM. Besides, I also want thanks to Mr. Khairul Anuar b. Rakiman where he also provides some information about the study of robotic arm where it provide me help too. More or less, Mr. Ahmad Yusairi b. Bani Hashim also provides the information about the sensor devices where this also provide me aid in this research. In addition, there are also lot friends I need to thanks for where they give me guidance and giving me strength to keep moving on for this research.

Yet, I here also have to thanks for the Professor Madya Dr. Zulkifilie bin Ibrahim that giving advise when I facing the electrical circuit problem. Not only that, I have also need to thanks to my cousin where they provide technically assistant for the project electrical circuit. I also have to thanks Mr. Parameswara Abdul Rahman that provide teaching about the programming knowledge when I facing the program design problem. Overall, I here really thanks for those who provide help when I facing problem for the project.

# TABLE OF CONTENT

Abstract	i
Abstrak	ii
Acknowledgement	iii
Table of Content	iv
List of Tables	v
List of Figures	vi
List of Abbreviations	vii
<b>1. INTRODUCTION</b>	<b>1</b>
1.1 Project Background	1
1.2 Robotic Arm Background	2
1.3 Objectives	6
1.4 Problem Statement	6
1.5 Benefit of the Project	7
1.6 Limitation of the Project	7
1.7 Project Scope	7
1.8 Organization of the project	8
<b>2. LITERATURE REVIEW</b>	<b>9</b>
2.1 Path Motion of Robot Arm and Wrist Manipulation	9
2.2 Control System of Robot Arm Operating System	11
2.3 Repeatability of the Pick and Place Robot Arm	12
2.4 Chronology	14
<b>3. METHODOLOGY</b>	<b>16</b>
3.1 Method of Study	16
3.2 Project Process Flowchart	18
3.3 Project Process Method	20



3.4	Project Procedures	23
3.3	Apparatus	25
<b>4.</b>	<b>RESULT</b>	<b>31</b>
4.1	Mechanical Product	31
4.1.1	The Robot Arm	31
4.1.2	Robot Kinematics	33
4.1.2.1	Forward Kinematics	34
4.1.2.2	Inverse Kinematics	36
4.1.2.3	Velocity Kinematics	39
4.1.2.4	Static Equilibrium	40
4.1.2.5	Trajectory Path Planning	41
4.2	Electrical Circuit	44
4.3	Designed Program	46
4.4	Demonstration of Pick and Place Process	46
<b>5.</b>	<b>DISCUSSION</b>	<b>47</b>
5.1	Operation	47
5.1.1	Gripper Mechanism	47
5.1.2	Joint 3 Arm Mechanisms	50
5.1.3	Joint 2 Arm Mechanisms	53
5.1.4	Base / Joint 1 Mechanism	56
5.1.5	Performance of Pick and Place Process	60
<b>6.</b>	<b>CONCLUSION</b>	<b>61</b>
6.1	Overall Project Overview	61
<b>7.</b>	<b>SUGGESTION</b>	<b>62</b>
7.1	Implementable Project Improvement	62
7.1.1	Automated Pick and Place Robotic Arm System	62
7.1.2	Environment Learning Pick and Place Robotic Arm System	62

## REFERENCES

63

## APPENDICES

- A Schematic PIC Diagram
- B Robot Arm Source Code
- C Circuit Board Diagram
- D Electrical Component Data Sheet
- E Hardware Data Sheet

## **LIST OF TABLES**

2.1	The chronology of the robot	14
-----	-----------------------------	----

## LIST OF FIGURES

1.1	UNIMATE robotic arm	4
1.2	Rancho Arm	4
1.3	Tentacle Arm	4
1.4	Stanford Arm	5
1.5	Modern robotic arms	5
3.1a	Flowchart of project	18
3.1b	Flowchart of project	19
4.1	Isometric view of the robotic arm	32
4.2	Side view of the robotic arm	33
4.3	Illustration of $\theta_1$	37
4.4	The angular position profile	42
4.5	The velocity profile	43
4.6	The acceleration profile	43
4.7	DC geared motor control circuit	44
4.8	Servo motor control circuit	45
4.9	Demonstration of operation	46
5.1	Gripper open	47
5.2	LED light on that react to the gripper open	48
5.3	Gripper close	49
5.4	LED light on that react to the gripper close	50
5.5	Joint 3 move downward	51
5.6	The corresponding LED light on when joint 3 move downward	51
5.7	Joint 3 move downward	52
5.8	The corresponding LED light on when joint 3 move upward	52
5.9	Joint 2 move downward	53

5.10	The corresponding LED light on when joint 2 move downward	54
5.11	Joint 2 move upward	55
5.12	The corresponding LED light on when joint 2 move upward	55
5.13	Joint 1 rotate anti-clockwise	56
5.14	The leading wheel rotate anti-clockwise	57
5.15	The corresponding LED light on when joint 1 rotate anti-clockwise	57
5.16	Joint 1 rotate clockwise	58
5.17	The leading wheel rotate clockwise	59
5.18	The corresponding LED light on when joint 1 rotate anti-clockwise	59
5.19	The performance of the robotic arm	60

## LIST OF ABBREVIATIONS

AGV	-	Automated Guided Vehicle
CAD	-	Computer Aided Design
DC	-	Direct Current
LED	-	Light Emitting Diode
NIST	-	National Institute of Standards and Technology
PDP-6	-	Programmed Data Processor-6
PIC	-	Programmable Integrated Circuit
PSM	-	Projek Sarjana Muda
SAIL	-	Stanford Artificial Intelligence Lab
IC	-	Integrated Circuit

# CHAPTER 1

## INTRODUCTION

In this section, an introduction toward project will be briefed. This introduction consists of background, objective and the benefit that it is contributed. It will explain what the serving purpose of this project is.

### 1.1 Project Background

Robotic arm is a general topic that been applied at many working field and study field at the recent time. There are many type of robotic arm was been studied for different application in order to replace the human workforce to improve the productivity. This project will be conducted by fabricate a 4 degree of freedom robotic arm that attachable on a Automated Guided Cart (AGV) in order to load and unload components or product from storage to assembly line or vice versa.

The application of robotic arm in the industry has provided a lot of aid toward the operator and it is also reduces human risk factor and accident rate. Thus, study on the robotic arm is keep on progressing and keep developing so that the robotic arm will be more user friendly. More possible, the robotic arm will able to act and react by itself, where needed to apply the Artificial Intelligent system on them. Through this, the production rate will increase and the product rejected rate will also decrease. Thus, this project will provide study of a 4 degree of freedom robotic arm that apply on the industry. The study of this research will provide the efficiency outcome of the pick and place robotic arm and the AGV application at the industry.

## 1.2 Robotic Arm Background

Robot can be say as a machine that move under their own power, or can be called as a mechanical or virtual, artificial agent. A robot can perform simple human task for many situation where human unable to perform there. The most significant example are the industrial robot, the robot was applied in order to carry object that heavier than human or under high temperature environment. Thus many developments were done on the robot area in order to bring much benefit to human.

Industrial robot is an advance technology that particularly replace labor resource who been used as the produce machine. With the aid of the industrial robot, the production line was improved. The first industrial robot who been invented during year 1961 by George Devol and Joseph F. Engelberger known as Unimate where so-called programmable transfer machine, which been used to transfer object from one point to another. It been applied at industry and work with heated die-casting machine to perform welding on auto bodies. It 4,000-pound arm is versatile enough to perform a variety of tasks in industry. This invention has brought a great benefit for industrial production line for a long time due to it high reliability and as an easy-to-use robot.

After that, at the year of 1963, Stanford University has designed another robotic arm that named as Rancho Arm. This robot arm was developed at Rancho Los Amigos Hospital in Downey, California. It is the first artificial robotic arm which was able be controlled by a computer. The invention was created as a tool for handicapped where it's six joints gave it the flexibility of a human arm.

No longer of that, at year 1965, a team lead by Ed Feigenbaum, with Bruce Buchanan, Joshua Lederberg, and Carl Djerassi that from Stanford has create a DENDRAL which is the first expert system or program designed to execute the accumulated knowledge of subject experts. DENDRAL applied a battery of "if-then" rules in chemistry and physics to identify the molecular structure of organic compounds by analyzing the organic compounds' mass spectra and using knowledge of chemistry.



With the knowledge of robotic that have start to be studied, much and more researcher has try to create or invent more function robotic device. At year 1968, an octopus-like robotic arm was developed by Marvin Minsky, which is Tentacle Arm. This serpentine-type robot arm had twelve joints designed to reach around obstacles which are more joints than UNIMATE. This robot arm was controlled by a PDP-6 computer, and powered by hydraulic fluids. When the Tentacle robot arm mounted on a wall, it could lift the weight of a person.

At the next year, which is 1969, the development on robotic arm has made a breakthrough. A person who named Victor Scheinman has created Stanford Arm, which is the first successful electrically powered, computer-controlled robot arm. This robot can be set in the data and continuous to work, which can reduce the cost for using human resource. Follow by that, there have other modified Stanford Arm which is the Stanford-Rancho Arm and Stanford Hydraulic Arm. The Stanford-Rancho Arm, which is a modified prosthetic arm, and the Stanford Hydraulic Arm, which also known as manipulator that operate at high speed but dangerous and difficult to be controlled, was designed so that it will be easily to be controlled and compatible with the existing computer system, the PDP-6, and the SAIL facilities.

At this modern day, more and more robotic arm was created and they can be categorized as Cartesian Robot, Cylindrical Robot, SCARA Robot, Spherical Robot, and Articulated Robot which are different by their movement about an axis, rotate or prismatic. The articulated robot arm is a robot that consists of rotary joints. It is been heavily applied at the industry due to its multi-joints where thus increase the accuracy of operating specific process at the specific place on the product. There is also having a robotic arm which named as Parallel Robot arm. This robot arm has six identical “legs” consisting of the serial connection of a Cardan joint (two rotational degrees of freedom), a prismatic joint (one translational degree of freedom), and a spherical joint (three rotational degrees of freedom). These robotic arms are thus be heavily apply at industry for assembly operation, storage, defect rejection process in order to replace the human workforce where they required more cost than apply the robot at the field.



**Figure 1.2.1:** UNIMATE robotic arm (Anonymous 1961)



**Figure 1.2.2:** Rancho Arm (Anonymous 1963)



**Figure 1.2.3:** Tentacle Arm (Anonymous 1968)

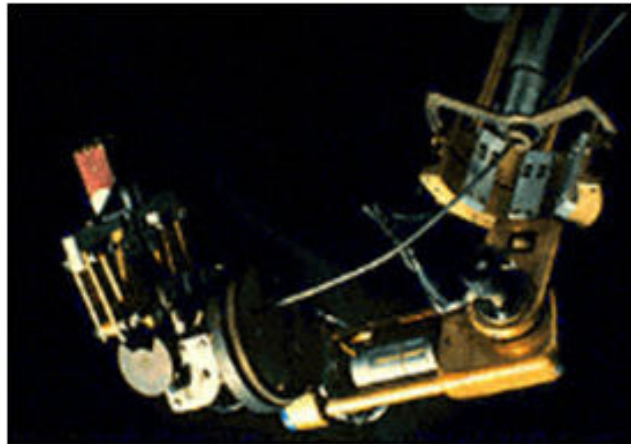

Figure 1.2.4: Stanford Arm (Anonymous 1969)

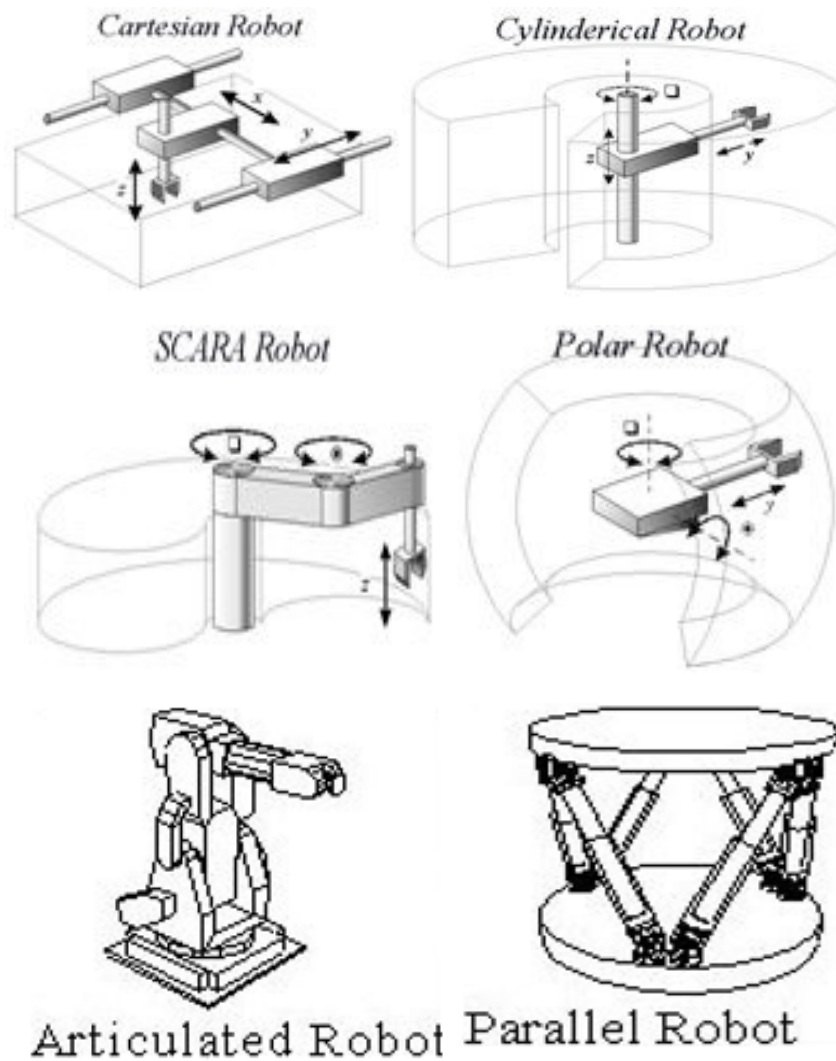

Figure 1.2.5: Modern robotic arms (Anonymous 2007)

### **1.3 Objective**

The objectives of the PSM program have been stated as below which are:

- (a) Design a robot arm that able to pick up the components for industry used.
- (b) Design the software so that the robot arm can be programmed to receive new task.
- (c) Study and analyze the designed robot arm in order to make improvement so that it is more suitable in the industry.

### **1.4 Problem Statement**

Nowadays, there are a lot of product has been invented for the human for more user friendly and also helping human more applicable at any activity. Thus, these have cause a lot of competition in between the manufacturing industrial sector where they need their product being produced as the fastest, most accurate, good quality, less defect, cost less, which is the most valuable toward the consumer by compare with other manufacturer. Thus, the application of robotic in the industry has rising where the robotic can provide more benefit, which like less cost demand, high accuracy of working efficiency and restless.

However, in the present manufacturing sector, there are still having many factories apply human as the main transporter of the components and products from storage department to assembly line. So, this has brought more cost toward the owner. Besides, the working time efficiency will also affect the production rate if compare toward the application of robot where human operator need rest so that they can continue work at the optimum working performance. Nevertheless, human sensor device, which is the vision, hearing, and touching, will also affect the working performance due to some factor like less concentration, no enough resting, and human tissue overload, which these will provide more error occurred and high risk of accident at the production line.

## **1.5 Benefit of the Project**

After the research, this project will provide the improvement in the industrial production line where it helps the operator collect components for product assembly operation. Through this, the production rate will increase for large scale type of product and the cost demand for production line will also decrease. Moreover, the system also operating in automated mode, which then can reduce the cost demand of the industry where the human workforce being reduced.

## **1.6 Limitation of the Project**

The project has to be done within few months and thus the design efficiency of the robot arm will provide a low quality of outcome. Besides, due to the financial limitation, the design of the robot arm will unable to provide more degree of freedom where these will provide the robot arm operate more accurately. Besides of that, the method of study the research also restrict the designer to provide a better robot arm design where there might have a lot of unpredictable problem or unknown event will faced unless the design was be virtualized. Thus, this might help the designer to study more deeply and able to produce the PSM report in more good quality.

## **1.7 Project Scope**

The project program scope will be concentrate on:

- (a) Designation of the robot arm,
- (b) Applicability of the robot arm,
- (c) Analysis of the robot arm when apply at the real time case,
- (d) Cost efficiency of the robot arm, and
- (e) Development and improvement of the robot arm.

## **1.8 Organization of the project**

The report will be conducted in few chapters and each has stated as below.

### **1.8.1 Chapter 1: Introduction**

This part will provide direction and introduction of the project

### **1.8.2 Chapter 2: Literature Review**

This part will provide relevant information and analysis for the project.

### **1.8.3 Chapter 3: Methodology**

This part will show how this project and report will be conducted.

### **1.8.4 Chapter 4: Result**

This part will show the conducted result of the project.

### **1.8.5 Chapter 5: Discussion**

This part will discuss the product and the operation.

### **1.8.6 Chapter 6: Conclusion**

This part will finalize the project.

### **1.8.7 Chapter 7: Suggestion**

This part will provide improvement suggestion of the product.

## **CHAPTER 2**

### **LITERATURE REVIEW**

In this section, all relevant study and expertise experience will be shown and project to support this study. This literature review will focus in the path motion of the robot arm and wrist manipulation, the control system of robot arm operating system and the repeatability of the pick and place robot arm.

#### **2.1 Path motion of robot arm and wrist manipulation**

Path planning of the robot arm in the workspace which is a function of time, which sufficiently describes the positions, orientations, linear velocities, angular velocities, and acceleration of the end-effector during the robot motion. Thus, in order to moving an object to a predetermined location by the robotic manipulator, the robot arm should be set up with multiple joint actuators and an end-effector for holding the object. So, this method of path planning has comprising the steps of (Hosek M. *et al.* 2003):

- (a) Selecting a reference point on the end-effector for determining a position of the end-effector,
- (b) Determining a motion path for movement of the reference point toward a predetermined location with a specified orientation,
- (c) Generating motion profiles for translation of the reference point along the motion path and rotation of the end-effector with respect to the reference point, and
- (d) Converting the motion profiles into joint motion profiles for implementing the movement of the end-effector to the predetermined location.

From the steps that been introduced at above, the robot arm will then learn how to move from components to the desired place from the cart. This method is requiring time to teach the robot how to move in a safe pathway to load and unload the components. Thus, there might provide a “brain” for the robot arm so that it will learn to move along the pathway by learn from itself. Thus, in order to control the motion and operation of robot arm associated with nonprogrammed positions during execution of a programmed cycle of operation, an apparatus is suggested where the positions and functions described by sets of input signals representing respectively coordinates of positions relative to a first coordinate system and function codes (Resnick B.J. 1984). The apparatus being connected to an external path generator for producing further sets of input signals and comprising of (Resnick B.J. 1984):

- (a) A manipulator upon which the function element is mounted having:
  - (i) A plurality of members describing a plurality of axes of motion, the members and axes of motion defining a generalized coordinate system, and
  - (ii) A plurality of actuators, each member having associated therewith at least one actuator for effecting motion of the member,
  
- (b) A manipulator control including a servomechanism circuit connected to the actuators to control motion of the members and executing the steps of:
  - (i) Producing an increment interval signal representing a period for completion of an increment of motion of the tool centerpoint along a predetermined path,
  - (ii) Producing an increment velocity signal representing the path velocity of the tool centerpoint during the increment period,
  - (iii) Producing end point coordinate signals in response to the increment interval signal and the increment velocity signal,
  - (iv) Means responsive to input signals received from the external path generator for terminating the reception of input signals there-from and for resuming the recalling of input signals from the memory.