

**HIGH VOLTAGE TESTING: INSULATION CHARACTERISTIC FOR  
DIFFERENT TYPES OF WOODS**

**KHAIRIL IZWAN BIN JASMAN**

**MAY 2009**

8“I hereby declared that I have read through this report and found that it has comply the partial fulfillment for awarding the degree of Bachelor of Electrical Engineering (Industrial Power)”

Signature : .....

Supervisor’s Name : AMINUDIN BIN AMAN

Date : 13 May 2009

HIGH VOLTAGE TESTING:  
INSULATION CHARACTERISTIC FOR DIFFERENT TYPES OF WOOD

KHAIRIL IZWAN BIN JASMAN

This Report Is submitted In Partial Fulfillment of Requirement for the Degree of  
Bachelor in Electrical Engineering (Industrial Power)

Fakulti Kejuruteraan Elektrik  
Universiti Teknikal Malaysia Melaka

May 2009

“I hereby declared that this report is a result of my own work except for the excerpts that have been cited clearly in the references.”

Signature : .....

Name : KHAIRIL IZWAN BIN JASMAN

Date : 13 MEI 2009

## ACKNOWLEDGEMENT

Alhamdulillah, thankful to ALLAH s.w.t for the smooth progress of my PSM final year report. I would also like to thank my supervisor Mr. Aminuddin bin Aman for his advices, critics, insight and willingness dealing with me to help me completing this project. Without him, surely I have difficulties to finish up this project.

I also would like to say thank you to my beloved course mate and my friend for their support and cooperation for me to finish this project. Not forgetting my dedication to my members of academic and technical staff of UTeM that guiding me directly or indirectly to complete this project.

Last but not least, I would like to thank the place that I begin for all the experiences and knowledge that I gained throughout my learning session in Universiti Teknikal Malaysia Melaka (UteM). All this valuable experiences will be useful in the future

## ABSTRACT

The high voltage test is to study the characteristic of insulator against high voltage stress. Many types of insulator are use to get the breakdown characteristics for high voltage such as solid, liquid and gasses. The primary goals for insulation are to provide adequate insulation over strengthens of the solid, provide high dielectric strength at low volume and weight, and function with minimal maintenance and ancillary components. Many types of insulator with different characteristics and different nominal voltages were tested to gets their specifics breakdowns. The dielectric breakdown voltage of an insulating insulator is of importance as a measure of the insulation ability to withstand electric stress. The parameters of the standard test methods from different countries are not similar. In the different standards there are used five to ten single test to gets the high voltage breakdown for solid (wood). That why, the purpose of this project is to study the characteristic of different types of solid (wood) against high voltage stress and to search their breakdown voltage. The comparison for all different type of solid (wood) is made to study their insulation characteristics for high voltage breakdown with all method.

## ABSTRACT

Ujian voltan tinggi adalah bagi mengkaji ciri-ciri penebat menentang tekanan voltan tinggi tekanan. Terdapat banyak jenis penebat digunakan untuk mencari ciri-ciri kerosakan bagi voltan tinggi seperti pepejal, cecair dan gas-gas. Matlamat utama projek ini adalah untuk mencari penebatan bagi menyediakan penebatan yang mencukupi untuk menguatkan pepejal, menyediakan kekuatan dielektrik yang tinggi pada volum rendah dan berat, dan fungsi penyenggaraan yang minimum dan bahagian-bahagian sampingan. Terdapat banyak jenis penebat dengan sifat dan voltan nominal yang berbeza telah diuji untuk mendapat ciri-ciri kerosakan-kerosakan bahan tersebut. Dielektrik voltan runtuh untuk satu penebat menebat adalah sangat penting sebagai satu ukuran bagi keupayaan penebatan untuk bertahan terhadap tekanan elektrik. Parameter bagi kaedah-kaedah ujian dari setiap Negara di dunia ini adalah berlainan dan tidak serupa dengan kaedah-kaedah yang berbeza, empat hingga sepuluh ujian dijalankan untuk mendapatkan voltan tinggi kerosakan untuk sesuatu pepejal (kayu). Oleh sebab itu, tujuan utama projek ini adalah untuk mengkaji ciri-ciri perbezaan antara jenis-jenis pepejal (kayu) melawan tekanan voltan tinggi dan untuk mencari voltan runtuh pepejal tersebut. Perbandingan antara ke semua pepejal (kayu) yang berbeza di buat untuk mengkaji ciri-ciri penebatan pepejal tersebut terhadap kerosakan voltan tinggi dengan semua kaedah yang ada.

## TABLE OF CONTENT

<b>CHAPTER</b>	<b>TITLE</b>	<b>PAGE</b>
	<b>DECLARATION</b>	<b>I</b>
	<b>ACKNOWLEDGMENT</b>	<b>IV</b>
	<b>ABSTRACT</b>	<b>V</b>
	<b>ABSTRAK</b>	<b>VI</b>
	<b>TABLE OF CONTENT</b>	<b>VII</b>
	<b>LIST OF FIGURES</b>	<b>X</b>
	<b>LIST OF TABLE</b>	<b>XII</b>
 <b>CHAPTER 1</b>	 <b>INTRODUCTION</b>	
	1.1 Background	1
	1.2 Problem Statement	2
	1.3 Objective	2
	1.4 Scope of the project	3
	1.5 Report Outline	3
 <b>CHAPTER 2</b>	 <b>LITERATURE REVIEW</b>	
	2.0 Introduction	5
	2.1 Generation of High Direct Current Voltage	6
	2.2.1 Half Wave Rectifier Circuit	6
	2.2.2 Full Wave Rectifier Circuit	7
	2.2.3 Greinacher Doubler-Circuit	8
	2.2 Generation of High Alternating Voltages	10



	2.2.1 Cascade Transformer	10
2.3	Generation of Impulse Voltages	11
	2.3.1 Lighting Impulse Waveform	11
	2.3.2 Single Stage Lighting Impulse Circuit	13
<b>CHAPTER 3</b>	<b>METHODOLOGY</b>	
3.0	Introduction	17
3.1	Literature review	19
3.2	Lab Testing	19
3.3	Data Collection, comparison and Conclusion	19
<b>CHAPTER 4</b>	<b>EXPERIMENTAL SETUP AND SAFETY</b>	
4.0	Introduction	20
4.1	Safety Procedure	20
	4.1.1 Laboratory safety	20
	4.1.2 Interlock system	21
	4.1.3 Equipment safety	21
	4.1.4 User Safety	22
4.2	Experimental Setup	23
	4.2.1 Main Component of High Voltage Components	25
	4.2.2 Charging and discharging unit	25
	4.3.2 Control and Triggering Unit	28
	4.3.3 Measurement Unit	30
4.4	Testing Procedure	31
	4.4.1 AC High Voltage Test Procedure	31
	4.4.2 DC High Voltage Test Procedure	33
	4.4.3 Impulse High Voltage Testing Procedure	35
4.5	Test Object Setup	38
	4.5.1 Wood Specimen and Preparation	38

	4.5.2	Type Tests on Insulator	38
<b>CHAPTER 5</b>		<b>RESULT AND DISCUSSION</b>	
	5.0	Introduction	40
	5.1	Experiment Result	40
	5.1.1	Dry wood test	41
	5.1.2	Soak in distill water test	44
	5.1.3	Impulse test with test object	47
	5.2	Discussion (result analysis)	50
<b>CHAPTER 6</b>		<b>CONCLUSSION AND RECOMMENDATION</b>	
	6.0	Conclusion	52
	6.1	Recommendation	52
		<b>REFERENCES</b>	
		<b>APPENDIXES</b>	

## LIST OF FIGURE

<b>NO</b>	<b>TITLE</b>	<b>PAGE</b>
2.1	Half Wave Rectifier	7
2.2	Full Wave Rectifier	7
2.3	Center-Tap Full Wave Rectifier	8
2.4	Two Stages Voltage Multiplier	8
2.5	Schematic diagram of the cascade transformer units	10
2.6	General shape and definitions of lighting impulse (LI)	12
2.7	Basic equivalent circuit impulse generator	14
2.8	Multistage impulse generator	16
3.0	flow chart	18
4.0	HV structure	24
4.1	HV supply	25
4.2	Energy storage capacitor	26
4.3	Sphere Gap	27
4.4	Resistor	27
4.5	Rod Discharge	28
4.6	OT 276	28
4.7	DMI 551	29
4.8	Digital Phosphor Oscilloscope	30
4.9	Measuring Sphere Gaps	31
4.10	AC 1 stage configuration	33
4.11	DC 1 stage configuration	35
4.12	Impulse 1 stage configuration	37
4.13	Wood specimen	38
5.1	AC Breakdown Voltages (kV) versus Number of Sample for dry wood	43

5.2	AC Breakdown Voltage (kV) versus Number of Sample for soak in distill water wood	44
5.3	DC Breakdown Voltage (kV) versus Number of Sample for dry wood	46
5.4	DC Breakdown Voltage (kV) versus Number of Sample for soak in distill water	47
5.5	Lightning impulse voltage at positive polarity	48
5.6	The front time of the lightning impulse voltage at positive polarity	48
5.7	The tail time of the lightning impulse voltage at positive polarity	48
5.8	Lightning impulse voltage at negative polarity	49
5.9	The front time of the lightning impulse voltage at negative polarity	49
5.10	The tail time of the lightning impulse voltage at negative polarity	49

**LIST OF TABLE**

<b>NO</b>	<b>TITLE</b>	<b>PAGE</b>
5.1	Results for AC Breakdown Voltage (kV) for Dry Wood	42
5.2	Results for AC Breakdown Voltage (kV) for Soak in Distill water	42
5.3	Results for DC Breakdown Voltage (kV) for Dry Wood	43
5.4	Results for AC Breakdown Voltage (kV) for Soak in Distill water	45
5.5	Result for Impulse voltage for dry wood (30kV)	45
5.6	Result for Impulse voltage for soak in distill water Wood (30Kv)	46

## CHAPTER 1

### INTRODUCTION

#### 1.1 Background

In modern time, high voltages are used for a wide variety of application covering the power system, industry and research laboratories. Such application have becomes essential to sustain modern civilization. High voltages are applied in laboratories in nuclear research, in particle accelerator, Van de Graaff generators and for insulation.

The most important characteristic of insulating materials and media is the short term electric strength for different breakdown probabilities. There are several types of insulation is use to find the breakdown characteristics for high voltage such as solid, liquid and gasses. Solid dielectric materials are used in all kinds of electrical apparatus and devices to insulate one current carrying part from another when they operate at different voltages. A good dielectric should have low dielectric loss, high mechanical strength, should be free from gaseous inclusion, and moisture, and be resistant to thermal and chemical deterioration [1].

This project focuses on HVAC, HVDC and impulse Voltage testing to find the best insulation from the waste wood in this country. Some experimental work will be studied such as HVAC, HVDC and impulse voltage construction kit to able all the lab season will conduct according to standard and safety that required. This project also will use waste woods as their insulation to find the highest breakdown will occur from the testing that will be conduct. From the result, the comparison and some analysis will be done to choose the better dielectric strength for this waste wood. Thus, the main objective

of this project is to determine the higher voltage breakdown and dielectric strength for solid (wood). In order to achieve the objective, it is very importance to comply the High Voltage testing standard such as IEEE standard and many more.

## 1.2 Problem Statement

There are no piece of electrical equipment that does not depends on electrical insulation in one form or an other to maintain the flow of electric current in desired path of the circuit. If due to some reasons the current deviates from the desired path, the potential will drop. In real insulation systems with solid insulation, partial discharges usually occur far below the breakdown voltage. In the long run, these lead to the destruction of nearly all solid insulating materials.

As we know, there are several different definitions for what defines high voltage. The definition of high voltage is any electric potential capable of producing breakdown in air around 600V [2]. That why, this is the preliminary study for the high voltage testing and high voltage strength again different types of testing (HVAC, HVDC and Impulse). This is the preliminary study on waste wood against waste wood as test object in order to determine their performance against different type nature of HV stress. By this study a new insulator could be develop by our local trees.

## 1.3 Objectives

The objectives of this project are:

- (a) to conduct HV test on waste wood where the type of nature of HV that use is HVAC, HVDC and Impulse voltage.
- (b) to determine electrical characteristics of these test wood as a sample against the HV test.
- (c) To make comparison and conclusion between each waste wood samples result in order to determine their breakdown strength.

#### 1.4 Scope of the research.

In this project, 2 type of wood will be use to find their breakdown. The woods that will be used in this project is:

- (1) types of wood
  - (a) *meranti merah*
  - (b) *selar kuning*
- (2) nature of High Voltage:
  - (a) HVAC (high voltage alternating current)
  - (b) HVDC (high voltage direct current)
  - (c) Impulse voltage
- (3) electrical characteristics to be study
  - (a) dielectric strength
  - (b) breakdown voltage

#### 1.5 Report Outline

For this report, it's divided into 5 chapters where is consisting:

- Chapter 1 : Introduction
- Chapter 2 : literature Review
- Chapter 2 : Methodology
- Chapter 3 : Safety and experimental setup
- Chapter 4 : Discussion and analysis
- Chapter 5 : Conclusion and recommendation

Chapter 1 is about introduction for the project that will be conduct, problem statement, and objective of the project and scope of this project. This project will be done according to the objective and scope of this project that state at earlier.

Chapter 2 presented about the operation of this project based on literature review and theory background. For this chapter will be explained how to generates High voltage using several methods such as AC, DC and impulse voltage. Studies on literature review helps in understanding about methods and their circuit diagram for generate high voltage.



.Chapter 3 will show the flow chart of methodology of the entire project that will conduct for this testing and with some brief explanation about the flow chart.

Chapter 4 is about safety and experimental setup that cover the major of this project. The safety that will be follow, High Voltage equipment and experimental work and testing procedure for the testing object will discuss in this chapter.

Chapter 5 will discuss about all the experimental result from this testing. All the data will be assembling in table before analyze it. All the data also will be discussed in the final section to explain all the possibilities that occur.

Chapter 6 will be conclude all the experimental work and testing that conduct in this project. Some suggestion will be given to help another student for their reference

## CHAPTER 2

### LITERATURE REVIEW

#### 2.0 Introduction

Generally, high voltage generators are applied in routine in testing laborites. Basically they are used for testing equipment such as transformer, bushing, cable, capacitor, switchgear, etc. The test is very important to confirm the reliability and efficiency of the product. With that, the high voltage testing equipment is required to study the insulation behavior under all conditions which the apparatus is likely to encounter.

The definitions for this research is about to find the best insulation of the solid (wood) with the different configuration. The best insulation of the object is depends to the value of breakdown voltage when the high voltage is apply. For insulation like wood, the highest and lowest breakdown that occurs will be the major of the insulation because that will predetermined either the testing object is good insulation or poor insulation.

Solid dielectric materials are used in all kinds of electrical circuits and devices to insulate one current carrying part from another when they operate at different voltages. A good dielectric should have low dielectric loss, high mechanical strength, should be free from gaseous inclusions, and moisture, and be resistant to thermal and chemical deterioration [3]. Solid dielectrics have higher breakdown strength compared to liquids and gases. Solid insulating materials, which are generally used in practiced, are two types, namely the organic materials, such as paper, wood and rubber, and the inorganic materials, such as mica, glass and porcelain, and synthetic polymers, such as Perspex, PVC, epoxy resins etc [3].

## 2.2 Generation of High Direct Current Voltages

High DC voltages are extensively used in applied physics, electro medical equipment, industrial applications and communication electronics. Instead of that, it is still needed in insulation test on cables and capacitor. Impulse generator charging units also require high DC voltages. Normally, for the generation of DC voltages of up to 100 kV, electronic valve rectifiers are used and the output currents are about 100 mA. The rectifier valve require special construction for cathode and filaments since a high electrostatic field of several kV/cm exists between the anode and the cathode in the non-conduction period [2]. Rectifier circuits for producing high DC voltages from AC sources may be:

- (a) Half wave rectifier
- (b) Full wave rectifier
- (c) Voltage doublers type rectifiers

### 2.2.1 Half Wave Rectifier Circuit

A half wave rectifier is using a simplest form of diode clipper – one resistor and a diode. In half wave rectification, either the positive or negative half of the AC wave is passed, while the other half is blocked. Because only one half of the input waveform reaches the output, it is very inefficient if used for power transfer. Half-wave rectification can be achieved with a single diode in a one phase supply [5]. Figure 2.1 shows the picture of half wave rectifier.

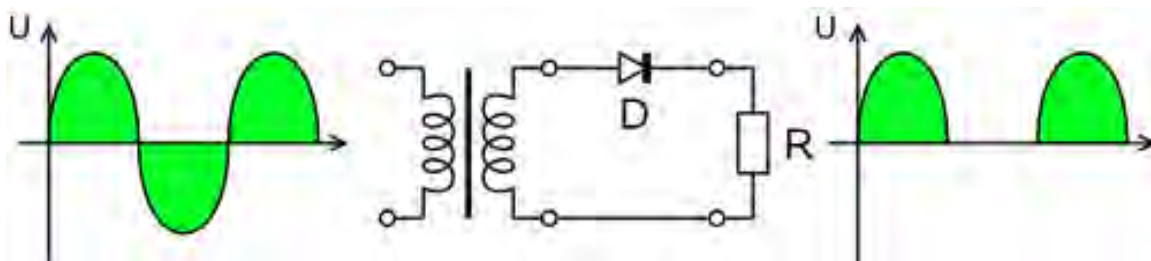

Figure 2.1: Half Wave Rectifier

### 2.2.2 Full Wave Rectifier Circuit

Full-wave rectification converts both polarities of the input waveform to DC (direct current), and is more efficient. However, in a circuit with a non-center tapped transformer, four diodes are required instead of the one needed for half-wave rectification. Four rectifiers arranged this way are called a diode bridge or bridge rectifier. Figure 2.2 shows the picture of full wave rectifier.

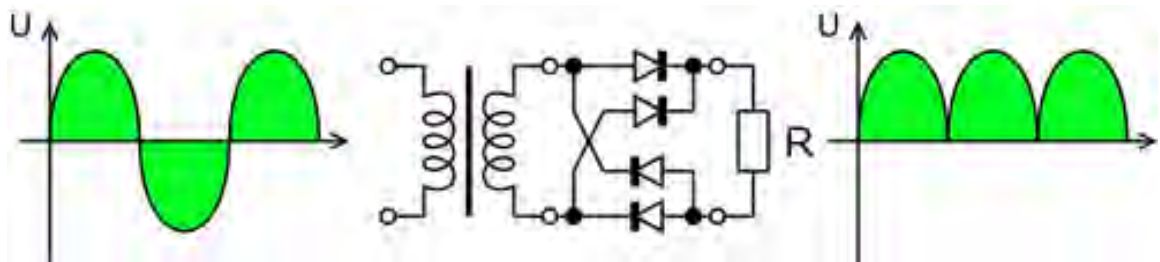

Figure 2.2: Full Wave Rectifier

A full wave rectifier converts the whole of the input waveform to one of constant polarity (positive or negative) at its output by reversing the negative (or positive) portions of the alternating current waveform. The positive (or negative) portions thus combine with the reversed negative (or positive) portions to produce an entirely positive (or negative) voltage/current waveform.

For single-phase AC, if the transformer is center-tapped, then two diodes back-to-back (i.e. anodes-to-anode or cathode-to-cathode) form a full-wave rectifier [4]. Figure 2.3 shows the picture of Center-Tap Full Wave Rectifier.

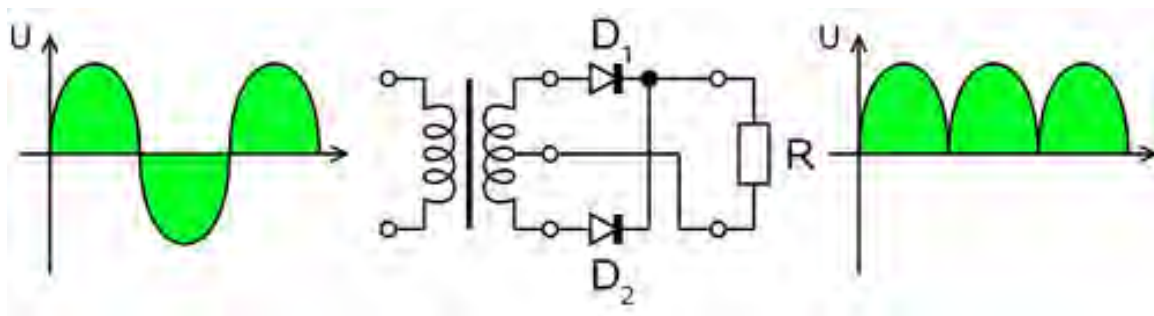

Figure 2.3: Center-Tap Full Wave Rectifier

### 2.2.3 Greinacher Doubler-Circuit

In 1920 Greinacher, a young physicist published a circuit which was improved in 1932 by Cockcroft and Walton. The circuit is quite practical for generating thousands of volts (or more) or just a few volts at high current. Since the circuit is AC-coupled it may be connected to a power supply's secondary transformer winding to generate an additional or opposite polarity voltage.

It mainly consists of a high voltage transformer  $T_s$ , a column of smoothing capacitors ( $C_2, C_4$ ), a column of coupling capacitors ( $C_1, C_3$ ), and a series connection of rectifiers ( $D_1, D_2, D_3, D_4$ ). The following description for the 2 stage CW multiplier assumes no losses and represents sequential reversals of polarity of the source transformer  $T_s$  in the figure shown below. The number of stages is equal to the number of smoothing capacitors between ground and OUT, which in this case, are capacitors  $C_2$  and  $C_4$ . figure 2.4 shows the picture of Two Stages Voltage Multiplier

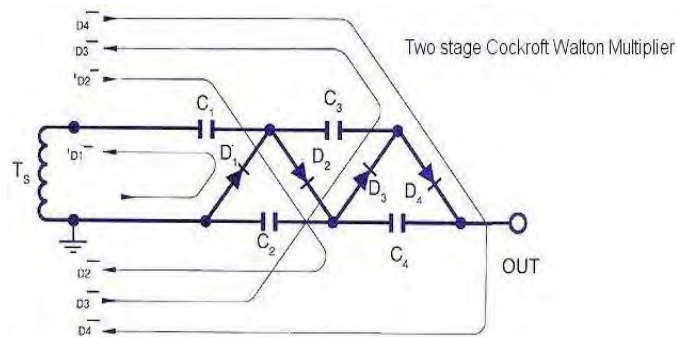

Figure 2.4: Two Stages Voltage Multiplier

Circuit flow:

1.  $T_s$ =Negative Peak:  $C_1$  charges through  $D_1$  to  $E_{pk}$  at current  $I_{D1}$
  2.  $T_s$ =Positive Peak:  $E_{pk}$  of  $T_s$  adds arithmetically to existing potential  $C_1$ , thus  $C_2$  charges to  $2E_{pk}$  through  $D_2$  at current  $I_{D2}$
  3.  $T_s$ =Negative Peak:  $C_3$  is charged to  $E_{pk}$  through  $D_3$  at current  $I_{D3}$
- $T_s$ =Positive Peak:  $C_4$  is charged to  $2E_{pk}$  through  $D_4$  at current  $I_{D4}$ .  
Output is then  $2n \cdot E_{pk}$  where  $N$  = number of stages.

With load, the output voltage is less than  $2nV_{\max}$ , where  $n$  is number of stages.

The ripple and voltage drop of the rectifier circuit may be estimated as:

$f$  = supply frequency

$q$  = charge transferred in each cycle

$I_1$  = load current from the rectifier

$t_1$  = condition period of the rectifier

$t_2$  = non-condition period of the rectifier

$dV$  = ripple voltage (peak to peak)

When  $I_1$  is supplied from  $C_2$  to load  $R_L$  during non-conducting period, the charge transferred per cycle from the capacitor  $C_2$  to the load during the non-conduction period  $t_2$  is  $q$ .

$$I_1 = \frac{q}{t_2} \quad , t_2 = \frac{1}{f} \quad (2.1)$$

$$q = C_2 dv \quad , dV = I_1 \frac{I_1}{fC_2} \quad (2.2)$$

So the ripple;

$$E_{\text{ripple}} = \frac{I_1}{f} \left[ \frac{I_1}{C_1} + \frac{2}{C_2} \right] \quad (2.3)$$

Therefore, the mean output voltage is

$$V_{\text{out}} = 2V_{\max} = -\frac{I_1}{f} \left[ \frac{1}{C_1} + \frac{2}{C_2} \right] \quad (2.4)$$

The voltage drop under load;

$$E_{\text{drop}} = \frac{I_1}{f} \left[ \frac{2}{3n^3} + \frac{n^2}{2} - \frac{n}{6} \right] \quad (2.5)$$

### 2.3 Generation of High Alternating Voltages

When test voltage requirements are less than about 300 kV, a single transformer can be used for test purposes. For higher voltage requirements, a single unit construction becomes difficult and costly due to insulation problems. Moreover, transportation and

erection of large transformers become difficult. These drawbacks are overcome by series connection or cascading of the several identical units of transformers, wherein the high voltage windings of all the units effectively come in series. Figure 2.5 shows the picture of cascade transformer. Figure 2.6 shows the picture of General shape and definitions of lightning impulse (LI).

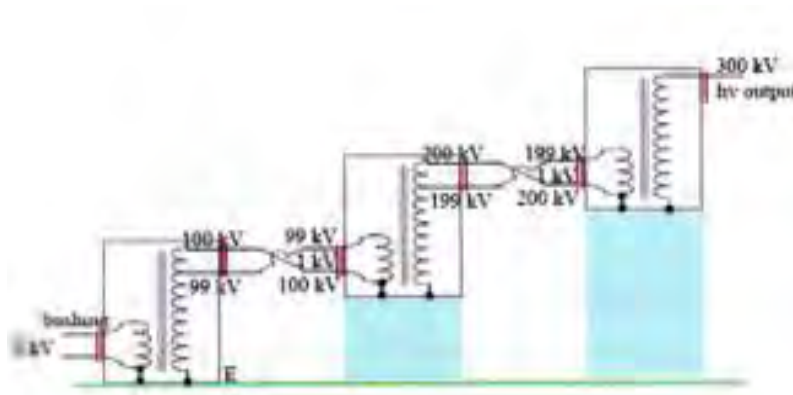

Figure 2.5: Schematic diagram of the cascade transformer units

### 2.3.1 Cascade Transformer

Figure shows a typical cascade arrangement of transformers used to obtain up to 300 kV from three units each rated insulation at 100 kV. The low voltage winding is connected to the primary of the first transformer, and this is connected to the transformer tank which is earthed. One end of the high voltage winding is also earthed through the tank. The high voltage end and a tapping near this end is taken out at the top of the transformer through a bushing, and forms the primary of the second transformer. One end of this winding is connected to the tank of the second transformer to maintain the tank at high voltage. The secondary of this transformer too has one end connected to the tank and at the other end the next cascaded transformer is fed. This cascade arrangement can be continued further if a still higher voltage is required [3].

In the cascade arrangement shown, each transformer needs only to be insulated for 100 kV, and hence the transformer can be relatively small. If a 300 kV transformer had to be used instead, the size would be massive. High voltage transformers for testing purposes are designed purposely to have a poor regulation. This is to ensure that when the secondary of the transformer is short circuited (as will commonly happen in flashover

tests of insulation), the current would not increase to too high a value and to reduce the cost. In practice, an additional series resistance (commonly a water resistance) is also used in such cases to limit the current and prevent possible damage to the transformer. The cascade transformer arrangement shown is the basic principle involved. The actual arrangement could be different for practical reasons

## 2.4. Generation of Impulse Voltages

### 2.4.1 Lighting Impulse Waveform

In high voltage technology, a single unipolar voltage pulse is term an impulse voltage. The time dependence, as well as the duration of the impulse voltage, depends upon method of generation. The various national and international standards define the impulse voltages as a unidirectional voltage which rises more or less rapidly to a peak value and then decays relatively slowly to zero.

In the relevant IEC Standard 60, widely accepted today through national committees, a distinction is made between lightning and switching impulses, i.e. according to the origin of the transients. Impulse voltages with front durations varying from less than one up to a few tens of microseconds are, in general, considered as lightning impulses.

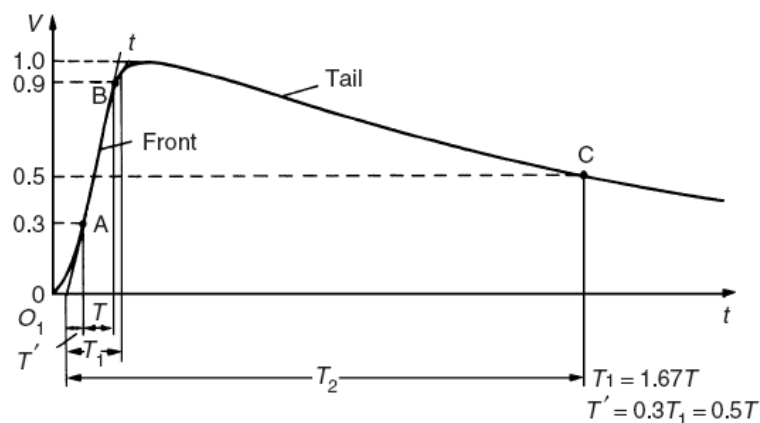

(a)