

**DESIGN AND DEVELOPMENT OF ANTILOCK BRAKING SYSTEM FOR MOTORCYCLE  
110 CC**

**AHMAD RIDHWAN BIN ABDULLAH**

**This report is completed to fulfill the part of terms of Bachelor of Mechanical Engineering  
(Automotive) rewarded**

**Faculty of Mechanical Engineering  
Universiti Teknikal Malaysia Melaka**

**MAY 2008**

I hereby admit that this thesis is sufficiently enough in terms of its scope and quality as the requirement for the degree of Bachelor of Mechanical Engineering (Automotive)

Signature

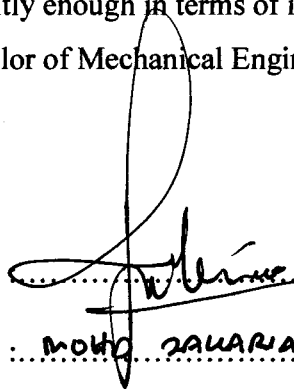

.....

Name of Supervisor

..... MOHD ZAHARA B MOHAMMAD NASIR

Date

..... 12 MAY 2008

"I admit that, this report has been written by myself accept the text and summary that each source, have been declare in this report".

Signature : *Ahmad*  
Author : AHMAD RIDHWAN BIN ABDULLAH  
Date : 27 MAC 2008

Untuk ayah dan ibu yang tersayang serta adik-beradik.

Tidak lupa juga kepada sahabat-sahabat dan orang perseorangan atau berkumpulan yang telah sentiasa memberi sokongan dan dorongan yang tidak berbelah bagi.

## **ACKNOWLEDGEMENT**

I would like to give appreciation and special thanks to my supervisor, En. Mohd Zakaria Bin Mohammad Nasir for the support and guidance that been given to me to complete this project.

Cooperation from others especially, laboratory management and also the technician that always share their knowledge during lab session.

This appreciation also been sent to the others that involved directly and indirectly help during this research. I hope that this report can be reference for other students.

## ABSTRACT

In the current development of brake manufacturing for the automotive industry, the Antilock Braking System (ABS) is commonly used in many modern vehicles today's. The system that can prevent wheel lockup during panic condition become popular amongst the car manufacturers as the additional equipments that related with safety features. Therefore for this research, it focused onto design new type of ABS to implement in motorcycles 110 cc. Further analysis and simulation will be done to identify function and characteristic of ABS and its effect to the driving condition. This research also will analyze the safety aspect during braking; calculate the slip rate and coefficient of friction. In this project, 'MATLAB' and 'Automation Studio' software are used in order to make the analysis, simulation and modeling of ABS. Comparison between performance of ABS and standard braking system will determine at the end of the research. Most of this project focus on the simulation and fabricate the electrical and hydraulic circuits that give same reaction like ABS.

## ABSTRAK

Dalam proses pembangunan semasa dan pembuatan Sistem Brek untuk industri automotive, Sistem Brek Anti-Kekunci merupakan system yang sering digunakan serta dipasang pada kenderaan-kenderaan moden pada masa kini. Sistem yang bertujuan untuk mengatasi masalah kuncian tayar semasa membrek dalam keadaan kecemasan, mula mendapat tempat dan seterusnya diaplikasikan oleh kebanyakan kilang-kilang kenderaan sebagai peralatan keselamatan tambahan pada kenderaan. Dalam kajian yang dijalankan ini, ianya memberi penekanan dalam merekabentuk Sistem Brek Anti-Kekunci yang boleh diaplikasikan pada kenderaan ringan seperti motosikal 110 cc. Analisis dan simulasi dijalankan untuk mengenal pasti fungsi Sistem Brek Anti-Kekunci serta kesannya terhadap pemanduan sesebuah kenderaan. Lanjutan pada kajian ini juga adalah mengenal pasti dan menganalisis aspek keselamatan semasa membrek; pengiraan kadar bagi sesebuah kenderaan itu untuk terbabas serta pemalar geseran. Bagi memudahkan kajian, perisian seperti 'MATLAB' dan 'Automation Studio' digunakan bagi tujuan analisis, simulasi serta mengkaji komponen yang sesuai bagi merekabentuk Sistem Brek Anti-Kekunci yang baru. Perbandingan dari segi prestasi antara Sistem Brek Anti-Kekunci diperolehi di akhir kajian ini. Secara keseluruhannya, fokus projek ini adalah pada simulasi dan penghasilan prototaip litar elektrik / hidraulik yang boleh menghasilkan tindakbalas seperti Sistem Brek Anti-Kekunci yang sedia ada.

## CONTENTS

CHAPTER	TITLE	PAGES
	<b>ACKNOWLEDGEMENT</b>	i
	<b>ABSTRACT</b>	ii
	<b>CONTENTS</b>	iii
	<b>LIST OF FIGURES</b>	vi
	<b>LIST OF SYMBOLS</b>	viii
<b>CHAPTER I</b>	<b>INTRODUCTION</b>	<b>1</b>
	1.1 Objectives of Project	3
	1.2 Problem Statement	3
	1.3 Scopes of Project	4
<b>CHAPTER II</b>	<b>LITERATURE REVIEW</b>	<b>6</b>
	2.1 Reviews about Braking System	6
	2.1.1 Basic Brake Hydraulic System Components	7
	2.1.2 Basic Hydraulic System Theory	9
	2.1.3 Physics of Brake Systems	9
	2.2 History of Antilock Braking Systems	10
	2.3 Basic Operation of Antilock Braking Systems	11



2.4	Basic Types of Antilock Braking Systems	13
2.4.1	One-Channel Systems	13
2.4.2	Two-Channel Systems	13
2.4.3	Three-Channel Systems	13
2.4.4	Four-Channel Systems	14
2.5	Previous research about Antilock Braking Systems in Motorcycle	14
<b>CHAPTER III</b>	<b>METHODOLOGY</b>	<b>17</b>
3.1	Theoretical Studies about Braking System	21
3.1.1	Equation of Motion during Brake For Half Motorcycle Model	22
3.2	Simulation Studies by using simulation software (MATLAB/Simulink)	24
3.2.1	Controller Design	25
3.2.2	Comparison between Simulation and Experimental Result	26
3.3	Design the brake system equipped with ABS and hardware in the loop study (Automation Studio)	27

<b>CHAPTER IV</b>	<b>RESULT</b>	<b>30</b>
4.1	Data Requirement	30
4.2	Comparison between ABS and standard braking system	33
4.3	Design Concept of ABS in Motorcycle	36
4.4	Design and Testing of Electrical Circuit	37
4.5	Simulation and Physical Testing Model Testing of Electrical / Hydraulic Circuit for ABS	43
<b>CHAPTER V</b>	<b>DISCUSSION</b>	<b>46</b>
<b>CHAPTER VI</b>	<b>CONCLUSION</b>	<b>55</b>
6.1	Conclusion	55
6.2	Recommendation	56
	<b>REFERENCE</b>	<b>58</b>
	<b>APPENDIX</b>	<b>60</b>

## LIST OF FIGURES

FIGURE	TITLE	PAGES
2.1	Brake Pedal Assembly, Power Brake Booster and Master Cylinder	8
2.2	The master cylinder is an apply piston, working as a pump, to provide hydraulic pressure to the output pistons at the wheel brakes	9
2.3	Kinetic energy increases proportionally with vehicle weight. Meanwhile, Kinetic energy increases exponentially with vehicle speed	9
2.4	Location of ABS in the most modern cars	11
2.5	ABS Circuit	11
2.6	BMW Motorcycle with ABS	14
2.7	BMW Integral ABS Components	15
2.8	BMW Integral ABS System	16
3.1	Flow Chart of Methodology Implementation of 'PSM' for 2 <sup>nd</sup> Semester, 2007-2008 Session	18-19
3.2	Gantt chart for Methodology Implementation of 'PSM' for 2 <sup>nd</sup> Semester, 2007-2008 Session	20
3.3	Half Motorcycle Model	22
3.4	ABS Controller for Half Motorcycle Model	25
3.5	Environment of 'Automation Studio' software	27
3.6	Ladder Diagrams	29

4.1	Model of 110 cc Motorcycle	31
4.2	Comparison between ABS and Standard Braking System by using ABS Controller for Half Motorcycle Model	32
4.3	Graph Velocity (m/s) versus Time (s)	33
4.4	Graph Distance (m) versus Time (s)	34
4.5	Concept of Design of ABS in Motorcycle	36
4.6	Design of Electrical Circuit for ABS in Motorcycle	37
4.7	Layout for Brake System	38
4.8	Hydraulic Circuit Design by using Automation Studio	38
4.9	Electrical Circuit for ABS using Ladder Diagram	39
4.10	Timer, Relay, and Electrical Circuit using 'Ladder Diagram'	40
4.11	Apparatus for Electrical Circuit testing for 'Ladder Logic'	41
4.12	Output Signal for 'Ladder Logic' Diagram	41
4.13	Simulation Result for combination between electrical circuit and hydraulic circuit in 'Automation Studio'	44
5.1	Graph Velocity versus Time (above) and Stopping Distance versus Time (below)	48
5.2	Experimental Result on Dry Asphalt surface for ABS equipped vehicle (left) and non-ABS equipped (right) during Straight Line Braking from 100 Km/h	49
5.3	Normal Braking Mode	51
5.4	Pressure Holding Mode	52
5.5	Pressure Reduction Mode	53
5.6	Pressure Increase Mode	54

## LIST OF SYMBOLS

$F_a$	=	Aerodynamic Force
$\chi$	=	Directional of Travel
$T_b$	=	Brake Torque
$\omega$	=	Wheel Rotational Speed
$F_z$	=	Normal Force
$F_t$	=	Friction Force on Tire
$F_f$	=	Tire Rolling Resistance
$F_z$	=	Normal Force
$R$	=	Radius of Tire
$L$	=	Wheelbase
$h_{cg}$	=	Height of Center Gravity
$m_{\text{motorcycle}}$	=	Mass of Motorcycle
$m_{\text{wheel}}$	=	Mass of Wheel
$C_d$	=	Coefficient of Drag
$g$	=	$9.81 \text{ m/s}^2$
$I_\omega$	=	Inertia of Wheel
$F_x$	=	Force on 'x' directional
$T_\omega$	=	Torque of Wheel

## CHAPTER I

### INTRODUCTION

The operation of ABS can be thought of as electronic/hydraulic pumping of the brakes for straight-line stopping under uncontrolled conditions. Sometimes, it is also called *antiskid braking* and has been used to some degree on domestic vehicles since the late 1960s. The early systems were used primarily on luxury cars as an extra-cost option and had limited popularity. Since the early to mid-1980s, ABS has become more popular and now standard equipment on many vehicle models. Most experts predict almost 80 percent usage of ABS on cars by the year 2000.

Wheel lockup during braking will cause skidding, and this will cause a loss of traction and vehicle control. A tire will generate its greatest amount of traction when it is slipping at a rate of 15 to 25 percent. This will result in longer stopping distances and possible accidents. ABS is designed to prevent wheel lockup and the resulting skid, even under the worst driving conditions, by automatically compensating for changes of traction or tire loading. ABS does not necessarily produce shorter stops, but it greatly improves the driver's ability to control the vehicle when trying to stop quickly.

For the cars that have not the ABS systems, driving skill is very important to control their vehicles even in any situation or any road condition. Skilled drivers have always pumped the brake pedal during panic stop to avoid wheel lockup and the loss of steering control. Antilock brake systems simply get the pumping job done much faster and in a much more precise manner than the fastest human foot. ABS is typically controlled by an electronic brake control module (EBCM) that relies on inputs from

several sensors. Keep in mind that a tire on the verge of slipping produces more friction with respect to the road than one that is locked and skidding. Once a tire loses its grip, friction is reduced and the vehicle takes longer to stop.

An ABS can pump the brakes up to fifteen times per second. Some systems can also control each brake separately whenever any one wheel starts to lock. An ABS can stop a car in the shortest possible distance without wheel lockup while stopping in a straight line. This condition is called directional stability. It allows the driver to steer the vehicle on most types of road surfaces while braking and maintain directional control.

An ABS is programmed to control negative wheel slip during braking. Negative wheel slip occurs when the speed of a wheel is less than vehicle speed. Integrated into some antilock system is traction control, which controls positive wheel slip (when the wheel speed is greater than vehicle speed during acceleration).

Generally, ABS begins with a standard brake system and adds one, two, three or four modulator or control valves, one to four speed sensors, and an electronic controller for the valves. The modulator valves are used to cycle the hydraulic pressure at the brake assemblies; the speed sensors determine the rotating speed of the wheel; and the electronic controller monitors the speed of the tires and operates and operates the modulator valves to prevent wheel lockup.

## **1.1 Objectives**

This project that must be fulfilled is still related with Antilock Braking System (ABS) that available in most modern vehicles today. Actually, not all motor vehicles are equipped with safety equipments like ABS that been studied now. Especially in motorcycles, there have less with safety equipment even there are most popular motor vehicle amongst peoples.

The main objectives of this project are to design and analysis ABS system that can be implementing in small motorcycle 110 cc. There are no manufacturers, except BMW Company that try to develop the ABS system in small motorcycle.

The installation of safety equipments like ABS can help to increase safety features in vehicles. As the result, it will reduce the risk of accident that face by the consumer. ABS currently improves the ability of the vehicles to stop its movement during braking, especially in emergency condition. This characteristic is needed by motorcycle because most of the accidents were involving the motorcycle riders. It only can be prevented by the awareness all persons especially by the owner of motorcycles.

## **1.2 Problem Statement**

During emergency braking, if a driver of a vehicle applies too much pressure to the brake pedal, the brakes will quickly cause the wheels to stop or “lock up”. Unfortunately, this action will not stop the vehicle at a faster rate. On the contrary, a skidding wheel uses a lower coefficient of friction than a rolling wheel. Furthermore, once this happens, the driver no longer has complete control of the vehicle. The manual solution is to “pump the brakes” by repeatedly applying pressure to the pedal and releasing when they lock up. But in an emergency situation, where there is only a split second window for action, what driver can act fast enough? Only a computer can perform



these actions quickly enough, as well as consistently over long periods of time. This application of computing power was introduced with the advent of the Antilock Braking System (ABS).

Nowadays, motorcycles become a famous light vehicle either in big cities or in downtown. Because the price of that vehicles that compatible to its function compare to passenger cars, make it available to all peoples. But, if we look at the safety side, motorcycles had much less with safety equipment than cars. So, there is no wonder if we always heard in television or read in newspaper about the accidents that happen involving the motorcyclist especially. Besides that, attitude of peoples that not followed the rules during riding the motorcycles become the factor that increased the statistic of accidents. The condition of the rider that been opened to environment during riding the motorcycles involving them in risk to involve on accident.

Because of these reasons, most of motorcycles need more safety equipment than usual like Antilock Braking system to prevent the riders from accident.

### **1.3 Scopes of Project**

In this project, firstly I need to study and understand the function of main component in Antilock Braking System and electrical hydraulic system for conventional locking devices. Although, there are many types of ABS, the basic component are commonly same in each system. The examples of the components are wheel speed sensor, ABS modulator, and electronic brake control modulator and more. Most of the ABS systems in modern cars consist of combination between hydraulic and electronic system.

Research for this project is referring to the previous model of ABS that implement in most modern cars. Model of ABS that being references is the ABS model that created by Bosch Company in 1995. That design is quite simple compare with other system of ABS. Electronic devices not widely been used at that time, and the operation of that ABS system is totally used the mechanical principle. But, it still can be modified with

combination of electronic / electrical devices. Cost that involved in developing this project can be reduced as much as possible.

A new model of ABS has been designed based on electrical / hydraulic circuit to equip in motorcycles. Software like 'Automation Studio' will be used to design the components as well as electrical circuit.

For further research, Computer Added Engineering software (CAE) like MATLAB will be used to analysis the performance of characteristic of ABS. Instead, experiment in laboratory will be held to analyze the ability and functional of the circuit that been newly designed. Experiment will be carried out in Hydraulic and Pneumatic Laboratory. An analytical study on critical components will be performed.

## CHAPTER II

### LITERATURE REVIEW

#### 2.1 Reviews about Braking System

The braking system can be defined from three separate functions that must fulfill at all times:

- a) The braking system must decelerate a vehicle in a controlled and repeatable fashion and when appropriate cause the vehicle to stop.
- b) The braking system should permit the vehicle to maintain a constant speed when traveling downhill.
- c) The braking system must hold the vehicle stationary when on a flat or on a gradient.

Slippery wet and dry roads, rough or smooth road, wet or dry brake are the diverse condition that must be considered, which the brake must operate leads to a better appreciation of their role. Clearly the brakes, together with the steering components and tires represent the most important accident avoidance systems present on a motor vehicle which must reliably operate under various conditions. The effectiveness of any braking is, however, limited by the amount of traction available at the tire-road interface.

### 2.1.1 Basic Brake Hydraulic System Components

a) Pedal assembly

It consists of an arm, pad and pivot attachments. A linkage is connected to the pedal and this transmits both force and movement to the master cylinder.

b) Brake booster

To amplify the foot pressure generated when the brake pedal is depressed @ increase the force of the driver's foot on the pedal.

c) Master cylinder

It is a cylindrical pump with two pistons that develop pressure in the hydraulic lines to the front and rear brakes.

d) Pressure control valve

Metering and proportioning valves modulate hydraulic pressure to front disc or rear drum brake to provide smooth brake application and reduce the tendency of the brakes to lock. An application, called the pressure differential switch, is used in most systems to illuminate the instrument-panel warning lamp if half of the hydraulic system loses pressure.

The ABS makes some common valves obsolete. An ABS electronic control module can modulate hydraulic pressure for normal braking better than metering and proportioning valves can. As ABS installations become more widespread, some older hydraulic functions may be given over to electronic controls.

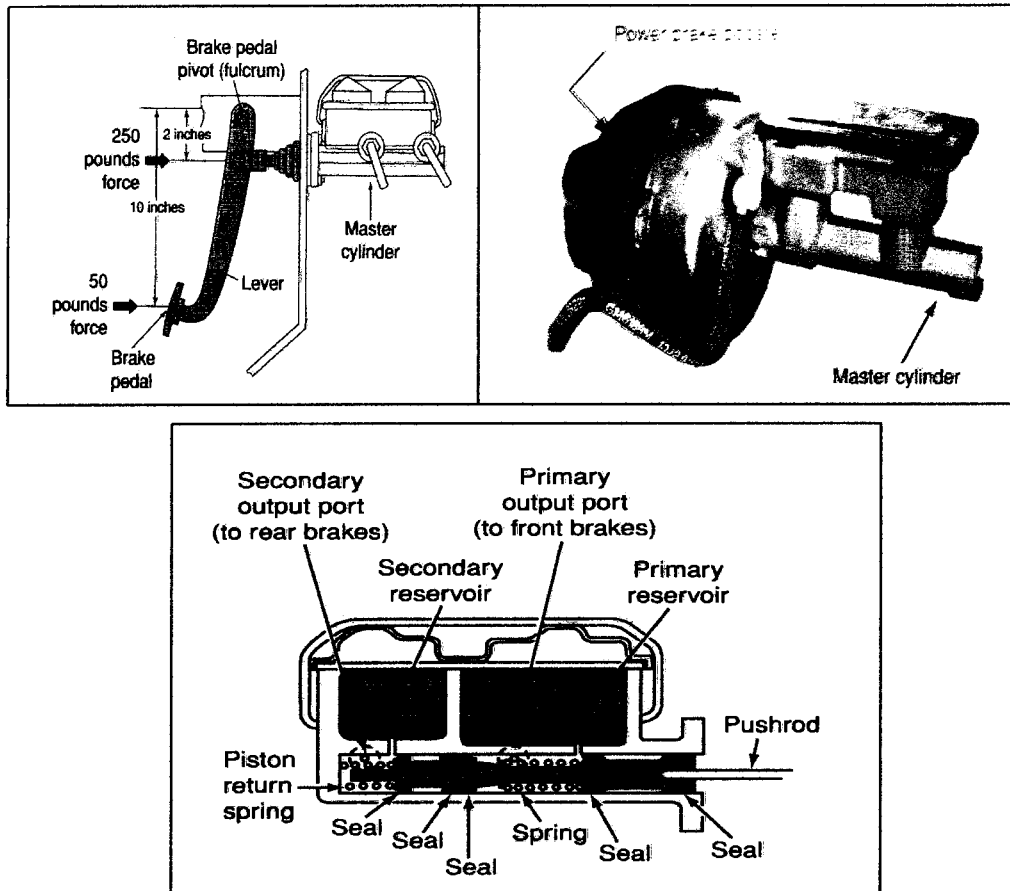

Figure 2.1: Brake Pedal Assembly, Power Brake Booster and Master Cylinder  
(Source: Erjavec, J. (2004))

### 2.1.2 Basic Hydraulic System Theory

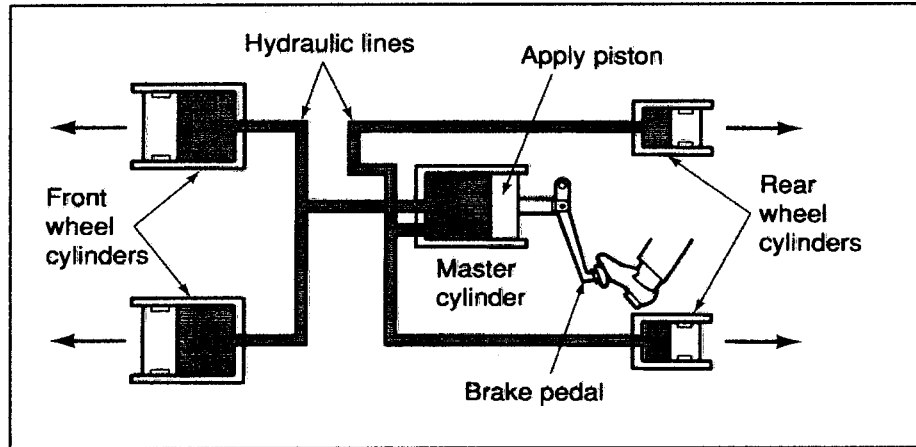

Figure 2.2: The master cylinder is an apply piston, working as a pump, to provide hydraulic pressure to the output pistons at the wheel brakes

(Source: Erjavec, J. (2004))

Pascal's Law says that when the force applied to close hydraulic system, it will create pressure and will be transmitted to all parts of liquid. The pressure applied to it is transmitted equally in all directions and this pressure acts with equal force at every point in the container.

### 2.1.3 Physics of Brake Systems

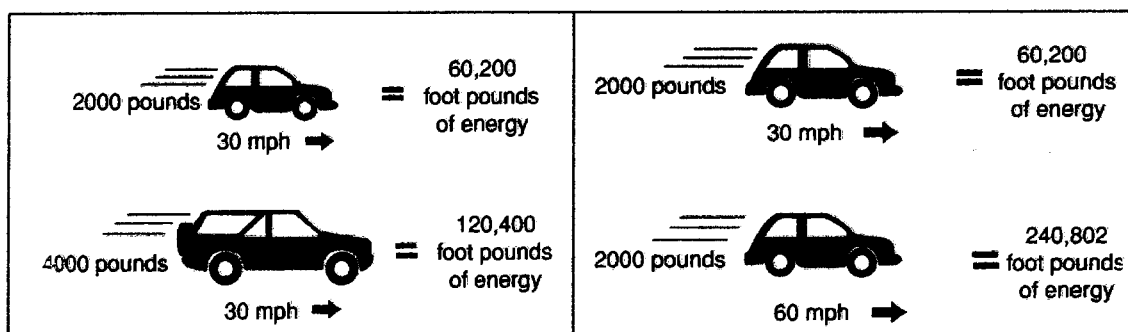

Figure 2.3: Kinetic energy increases proportionally with vehicle weight. Meanwhile, Kinetic energy increases exponentially with vehicle speed.

(Source: Erjavec, J. (2004))

## 2.2 History of Antilock Braking Systems

Anti-lock braking systems were first developed for aircraft in 1929 by the French automobile and aircraft pioneer Gabriel Voisin, as threshold brake an airplane is nearly impossible. An early system that been created by Dunlop was introduced in the 1950s and still in use on some aircraft models. In 1936 the German Companies Bosch and Mercedes-Benz pioneered the first electronic version for use on Mercedes Benz cars.

The functional of fully mechanical system had less used in car in 1960s. Because of that price are too expensive and looked unreliable to use in automotive industries, only certain manufacturers that used this system in their 'products' like Ford company. However, a limited form of anti-lock braking, utilizing a valve which could adjust front to rear brake force distribution when a wheel locked was found in 1964 by 'Austin' company.

The German firms Bosch and Mercedes-Benz had been co-developing in researches of anti-lock braking technology since the 1930s and their first system had been appeared in trucks and the Mercedes-Benz S-Class. ABS Systems were later introduced on other cars and motorcycles. As the result, a really automobile ABS was designed by Bosch in 1978. In 1985 Mercedes Benz offered ABS as standard equipment on its S-class models. In 1991 only about 18% of all new cars sold came equipped with antilock brakes. Now that number is over 90%.

### 2.3 Basic Operation of Antilock Braking Systems

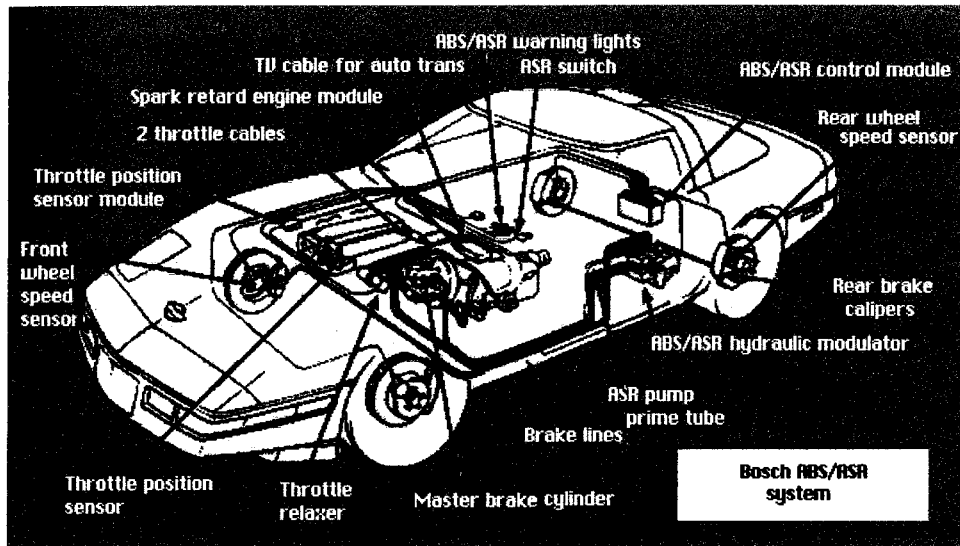

Figure 2.4: Location of ABS in the most modern cars

(Source: Carley, L. (2006))

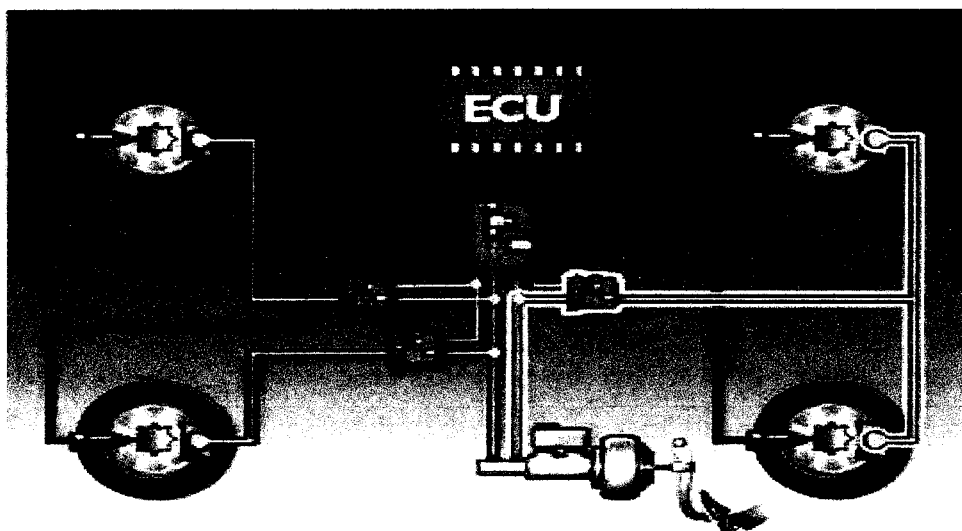

Figure 2.5: ABS Circuit

(Source: CDX Global & Wikipedia - en.wikipedia.org)