



UNIVERSITI TEKNIKAL MALAYSIA MELAKA

**DESIGN A BENDING MACHINE FOR BOWL FEEDER
ATTACHMENT**

This report is submitted in accordance with requirement of the Universiti Teknikal Malaysia Melaka (UTeM) for the Bachelor Degree of Manufacturing Engineering (Robotic & Automation) with Honours.

by

AMIRUL FARHAN B MOHD SALIH

FACULTY OF MANUFACTURING ENGINEERING

2010



UNIVERSITI TEKNIKAL MALAYSIA MELAKA

BORANG PENGESAHAN STATUS LAPORAN PROJEK SARJANA MUDA

TAJUK: **Design A Bending Machine For Bowl Feeder Attachment**

SESI PENGAJIAN: 2009/10 Semester 2

Saya **AMIRUL FARHAN B MOHD SALIH**

mengaku membenarkan Laporan PSM ini disimpan di Perpustakaan Universiti Teknikal Malaysia Melaka (UTeM) dengan syarat-syarat kegunaan seperti berikut:

1. Laporan PSM adalah hak milik Universiti Teknikal Malaysia Melaka dan penulis.
2. Perpustakaan Universiti Teknikal Malaysia Melaka dibenarkan membuat salinan untuk tujuan pengajian sahaja dengan izin penulis.
3. Perpustakaan dibenarkan membuat salinan laporan PSM ini sebagai bahan pertukaran antara institusi pengajian tinggi.
4. **Sila tandakan (v)

SULIT

(Mengandungi maklumat yang berdarjah keselamatan atau kepentingan Malaysia yang termaktub di dalam AKTA RAHSIA RASMI 1972)

TERHAD

(Mengandungi maklumat TERHAD yang telah ditentukan oleh organisasi/badan di mana penyelidikan dijalankan)

TIDAK TERHAD

Disahkan oleh:

(TANDATANGAN PENULIS)

(TANDATANGAN PENYELIA)

Alamat Tetap:

163, Jln Manggis, Tmn Sri Jaya,
Bkt Gambir, 84800,
Ledang, Johor

Cop Rasmi:

Tarikh: _____

Tarikh: _____

** Jika Laporan PSM ini SULIT atau TERHAD, sila lampirkan surat daripada pihak berkuasa/organisasi berkenaan dengan menyatakan sekali sebab dan tempoh laporan PSM ini perlu dikelaskan sebagai SULIT atau TERHAD.

DECLARATION

I hereby, declared this report entitled “Design A Bending Machine For Bowl Feeder Attachment” is the result of my own research except cited in the references.

Signature :

Author's name :

Date :

APPROVAL

This report is submitted to Faculty of Manufacturing Engineering of UTeM as a partial fulfillment of the requirements for the degree of Bachelor of Manufacturing Engineering (Robotic & Automation) with Honours. The member of supervisory committee is as follow:

(Signature of Supervisor)

.....

()

ABSTRACT

Bending machine is a common tool in machine shop that is used to bend a metal. It is widely used in various industrial operation such as bending a tube to make coil or sheet metal to make certain shape such as „V“ shape. There are many kind of bending machine that can be found in the market such as press brake bending machine, roll bending machine, and folding machine. In this project, designing a bending machine specifically for bowl feeder attachment. There is no proper small scale bending machine for bending a sheet metal for bowl feeder attachment. In this project, all the necessary criterion of small scale bending machine to be considered such as roller bending type to be used, the design of the bending machine, the method of assembly the machine parts and the consideration of material need to be bend. A generation of idea to design a bending machine will be executed according to the design parameters. Moreover, the analysis of the design of bending machine will be analyzed using a software known as COSMOSXpress in Solidworks which can run finite element analysis. The analysis is undergo three analysis which are bending structure analysis, roller bending analysis, and turbine shaft analysis. The software will generate the most stress occurred in the analysis and then can be further discuss about the analysis. Lastly, a conclusion can be made about the progress and findings of the PSM project and future work that can be suggested.

ABSTRAK

Mesin membengkok ialah peralatan umum di dalam mesin shop digunakan untuk membengkokkan besi. Ianya digunakan dengan meluas di dalam pelbagai operasi industri seperti membengkokkan tiub untuk membentuk lingkaran atau lembaran besi untuk membentuk bentuk seperti bentuk „V“. Terdapat pelbagai jenis mesin membengkok yang boleh dijumpai di pasaran seperti mesin membengkok jenis “press brake”, mesin membengkok jenis “roll” dan mesin melipat. Di dalam projek ini, merekabentuk mesin membengkok khas untuk sambungan tambahan mangkuk suapan. Tiada mesin membengkok berskala kecil untuk membengkok lembaran besi untuk sambungan tambahan mangkuk suapan. Didalam projek ini, semua criteria mesin membengkok berskala kecil yang diperlukan akan dipertimbangkan seperti jenis „roller“ membengkok untuk digunakan, rekabentuk mesin membengkok, kaedah memasang bahagian-bahagian mesin dan pertimbangan bahan digunakan untuk dibengkokkan. Penghasilan idea merekabentuk mesin membengkok akan dilaksanakan merujuk kepada parameter rekabentuk. Tambahan lagi, analisis rekabentuk mesin membengkok akan dianalisis menggunakan perisian komputer dikenali sebagai COSMOSXpress di dalam Solidworks dimana ianya boleh menjalankan analisis „finite element“. Analisis menjalankan tiga analisis iaitu analisis struktur membengkok, analisis penggelek pembengkok dan analisis turbin shaft. Perisian computer ini akan menghasilkan stress paling banyak berlaku di dalam analisis dan kemudian dibincangkan tentang analisis tersebut. Akhir sekali, kesimpulan akan dibuat tentang perjalanan projek PSM ini dan cadangan kerja pembaikan yang akan datang akan dicadangkan.

DEDICATION

*To my beloved father and mother who give me the strength and aspiration to move forward
and grasp the dreams of my life.*

ACKNOWLEDGEMENT

Assalamualaikum and full of grateful to Allah S.W.T. because the PSM project is successfully finish in duration of one year completing the PSM project. I would like to thanks to my supervisor Dr. Mohd Rizal b Salleh who guided me from the start until the end of this PSM project. Not forget to my fellow friends who also help me in a medium of giving suggestion, solution and so on. With the strong efforts, strong inspirations and hardworking, finally, this PSM project is successfully completed. Once again, thanks to my supervisor and friends.

Wassalam.

TABLE OF CONTENT

Table of content	i
List of tables	iv
List of figures	v
1. INTRODUCTION	
1.1 Overview	1
1.2 Problem statements	2
1.3 Objectives of the study	4
1.4 Scope of the study	4
2. LITERATURE REVIEW	
2.1 Overview	7
2.2 Reasons to design a bending machine for bowl feeder attachment	7
2.3 Existing bending machine	8
2.4 Classification of bending machine	11
2.4.1 Three roll bending machine	11
2.4.2 Two roll bending machine	12
2.5 Working principle of bending operation and bending sequences	14
2.6 Component features considered in designing the bending machine	17
2.6.1 Design	17
2.6.2 Fastener	18
2.6.2.1 Classification by intended use	18
2.6.2.1.1 Bolt and machine screw	18
2.6.2.1.2 Stud	19

2.6.2.2 Classification by thread type	20
2.6.2.2.1 Tapping screw	20
2.6.2.3 Classification by head style	20
2.6.2.3.1 Slotted screw	20
2.6.2.3.2 Socket head cap screw	20
2.6.3 Gear	22
2.6.3.1 Types of gear	22
2.6.3.1.1 Spur gear	22
2.6.3.1.2 Helical gear	23
2.6.3.1.3 Bevel gear	24
2.6.4 Bearing	26
2.6.4.1 Types of ball bearing	27
2.6.4.1.1 Single row radial, non filling slot	28
2.6.4.1.2 Single row radial, filling slot	28
2.6.4.1.3 Single row, angular contact	29
2.6.4.1.4 Double row bearing	30
2.6.4.2 Types of roller bearing	31
2.6.4.2.1 Cylindrical roller	31
2.6.4.2.2 Spherical roller	32
2.7 Material used for bending	33
2.7.1 Bending capability	34
2.8 Conclusion	37
3. METHODOLOGY	
3.1 Introduction	39
3.2 Classification of task	41
3.3 Conceptual design	41
3.4 Detail design	41

LIST OF TABLES

2.1 Types of stainless steel	35
2.2 Table of stainless steel and its properties	35
2.3 Unified Numbering System (UNS) for metals and alloy	37
4.1 Need-matics matrix	44
4.2 Concept combination table	54
4.3 Concept screening	60
4.4 Concept scoring	61
4.5 Table of parts and functions	63

LIST OF FIGURES

1.1 An illustration of feeding module	3
1.2 An illustration of bowl feeder, the region of the red line is the bowl feeder attachment	4
1.3 Methodology	6
2.1 An example of air bending and bottoming	9
2.2 Illustration of press brake bending machine	9
2.3 Illustration of roll bending machine	10
2.4 Illustration of folding machine	11
2.5 Conventional Pitch bending	11
2.6 Pyramid type bending	12
2.7 Two rolls bending machine	13
2.8 Initial stage of bending sheet metal	15
2.9 Position of pre-inactive and pre-active side roll bending	16
2.10 Steps of bending thin sheet metal	16
2.11 Steps of bending thick sheet metal	17
2.12 Example of bolt, machine screw and stud	19
2.13 Various styles of Heads Used on Small Machine Screws, (Courtesy of Cordova Bolt Inc.m Buena Park, Calif.)	21
2.14 Various styles of Socket-Head Cap Screws, (Courtesy of Cordova Bolt Inc.m Buena Park, Calif.)	21
2.15 Illustration of spur gear	23

2.16 Illustration of gear helix	24
2.17 Straight bevel gear	25
2.18 Spiral bevel gear	25
2.19 Zerol bevel gear	26
2.20 Hypoid bevel gear	26
2.21 Example of roller	27
2.22 Illustration of single row, non filling	28
2.23 Illustration of single row radial, filling slot	29
2.24 Single row, angular contact bearing	30
2.25 Illustration of double row bearing	31
2.26 Illustration of cylindrical roller	32
2.27 Bearing design of cylindrical roller	32
2.28 Illustration of spherical roller	33
3.1 Methodology	40
4.1 Five steps method	46
5.1 A picture of nodes and elements a gear tooth model	66
5.2 An illustration of constraint at the base	68
5.3 An illustration of force applied at the edge of bending neck	69
5.4 A result of finite element analysis on bending structure	69
5.5 An illustration of an effect when a force is applied at the edge of bending structure	69
5.6 An illustration of constraint at the roller bending	70
5.7 An illustration of force applied at the splitted area on the bending roller	71
5.8 A result of finite element analysis on the roller bending	71
5.9 An illustration of applied force distribution on a roller bending	71

5.10 An illustration of constraint at the key hole of a turbine shaft	72
5.11 An illustration of a force applied at the turbine shaft	73
5.12 A result of finite element analysis on the turbine shaft	73
5.13 An illustration of a force distribution on the turbine shaft	73

4. DESIGN OF BENDING MACHINE

4.1 Overview	43
4.2 Specification	44
4.3 Conceptual design overview	45
4.3.1 Clarify the problems	47
4.3.2 Search externally	48
4.3.3 Search internally	48
4.3.4 Explore systematically	53
4.3.5 Reflect on the solution and the process	59
4.4 Concept selection	59
4.5 Sequence of operation	62
4.6 Functions of bending machine parts	63
4.7 Material	64

5. ANALYSIS AND DISCUSSION

5.1 Overview	65
5.2 Finite element analysis	65
5.3 Discussion	67
5.3.1 Bending structure analysis	67
5.3.2 Roller bending analysis	70
5.3.3 Turbine shaft analysis	72
5.4 Conclusion	74

6. CONCLUSION

6.1 Further improvement works and suggestion	76
--	----

REFERENCES	77
-------------------	-----------

APPENDICES

CHAPTER 1

INTRODUCTION

1.1 Overview

This study is about the work of designing a bending machine to bend a sheet metal for bowl feeder attachment. A bending is a process of bending a metal. The metal can be a sheet metal, tubes, square hollow, rod, and iron angle. This type of metal has its own thickness. The bending machine designer will take into consideration a number of factors including type of metal, type of the roller bender, power driven or manual and the size of the bending machine. Usually, the difference of these types of bending machine is only on the capacity of the bending machine that can bend a sheet metal or tube. Today, the bending machine that available in the market is for the sheet metal and tube bending machine. Many machine makers vary their products based on the capacity of the bending machine and power driven or manual. Moreover, most of the machine uses roll bending type. This type of machine has 3 rolls which is 1 roll is fixed and the other 2 are adjustable. The sheet metal needs to put in the roller and then rolls around it until the desire shape is acquired. The products that can be produced with this machine are coil, truncated cone, etc.

1.2 Problem statement

Manufacturing is a field of transferring raw material into finished goods. There are many manufacturing firms that can be found such as automobile factories, bakery factories, electrical factories, etc. Many of the factories produce their products in mass production. So, these factories or companies are competing each other to get their products in the market. Therefore, they must have good manufacturing facilities to improve their productivity. To produce their products into mass production, the manufacturers also must have assembly machine in order to improve. This assembly machine consists of several feeding module. This feeding module consists of bowl feeder, bowl vibrator, linear track and linear track vibrator. The important of this feeding module is how fast it can feed the parts into assembly machine so that the assembly machine can assemble the parts to become finish products. This depends on the quality of the bowl feeder manufactured. The important part of the bowl feeder is the bowl feeder attachment. This bowl feeder attachment will determine the lead time of product assembly process and it depends on the bending process.

The problem arises during the fabrication of bowl feeder attachment is the unavailability of proper bending machine to bend a sheet metal to desire bending limit. The bowl feeder attachment designs are varied and it is depend on the customer requirement. Due to the unavailability of proper bending machine, the work of bending the sheet metal become harder. The machinists have to use other alternatives such as bending the sheet metal manually using their hands. For example, the table is used to bend the sheet metal by inserting the sheet metal between the gap of table top. If the sheet metal is not match with the bowl, the machinists have to do rework. It depends on the skill of the machinists. If the sheet metal cannot be used because of its worse condition, the machinists have to cut a new sheet metal and do the bending process again. The machinists have to do the bending process until it gets the sheet metal bend correctly. From this action, it consumes a lot of time and very costly. This also can cause a decreasing in productivity.

The other problem of bending is uneven surface on the sheet metal due to hand bending using plyers. If the attachment of the bowl feeder is uneven, the parts of certain components are hard to feed to the machine. The parts have to overcome the gravity force that pulls the parts backward. Moreover, it takes longer time to feed the parts into the machines. When the time is longer, the productivity is decreasing. This will influence the output quantity of feeding because when the surface is not even, the parts is hardly feeded into the machine.

Matching the bowl feeder attachment to the bowl feeder is another process in feeding module. The bending of the sheet metal is a common process and it is done by human. Human can cause error when do the bending process. Therefore, the machinists are tending to do mistake and thus the bending of the sheet metal cannot be done only once. It needs several times to bend the sheet metal to get the shape of the bowl feeder so that the necessary attachment is match with the bowl feeder. Moreover, when doing the bending processes, the sheet metal have the spring back force and this type of force will need the machinists to bend the sheet metal several times.

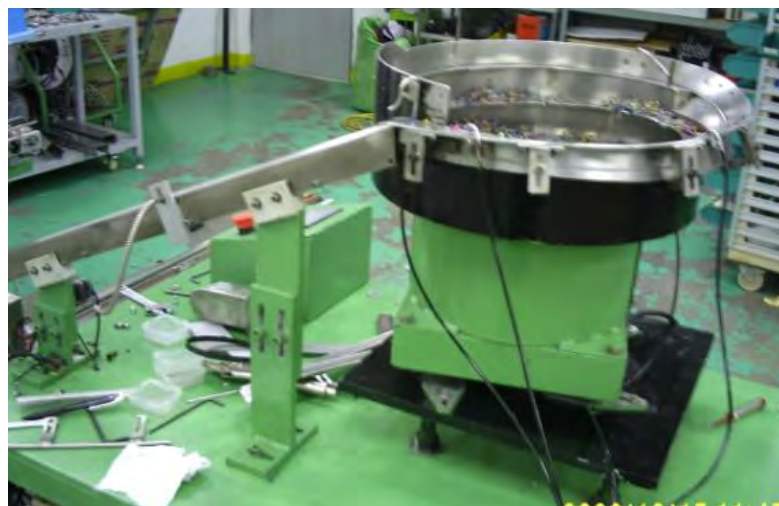

Figure 1.1: An illustration of feeding module, picture taken at Solid Heat (M) Sdn Bhd dated 15.10.2009



Figure 1.2: An illustration of bowl feeder, the region of the red line is the bowl feeder attachment, picture taken at Solid Heat (M) Sdn Bhd dated 15.10.2009

1.3 Objective of the study

The objectives are as below:

1. To investigate the difficulties in sheet metal bending for bowl feeder attachment.
2. To design a small scale sheet metal bending machine.
3. To analyze the performance of the proposed bending machine.

1.4 Scope of the study

The design of bending machine is based on three scopes of the study. The scopes of the study are encompasses investigation of the difficulties in sheet metal bending for bowl feeder attachment, the methodology of the study and the analysis of the proposed design of bending machine using a software known as COSMOSXpress.

This study starts with investigation of the difficulties in sheet metal bending for bowl feeder attachment. The investigation is starting with stating with the problem statements. The idea of designing a bending machine can be seen clearly through the problem statements, which is a solution of designing a bending machine can be generated to encounter those problems. From this investigation, a literature review can be conducted. In the literature review, it will discuss about the reason to design a bending machine for bowl feeder attachment, the comparison of existing bending machine, classification of bending machine, working principle of bending machine, etc.

In methodology, the first process is identifying the need of designing a bending machine. A design will be based on the necessary criterion of a small scale bending machine can be continued. In conceptual design, a basic design is generated. When the best design is chosen, that design will undergo detail conceptual design. Every machine parts are considered in detailed conceptual design so that it is suitable with the process of bending a sheet metal. Next, design analysis will be conducted on the detail conceptual design. After that, evaluation is conducted to evaluate the design of bending machine. Lastly, report writing need to be written.

After the project has gone through an investigation and methodology, an analysis of the performance of the proposed bending machine is conducted. Finite element software will be to analyze the performance of bending machine.

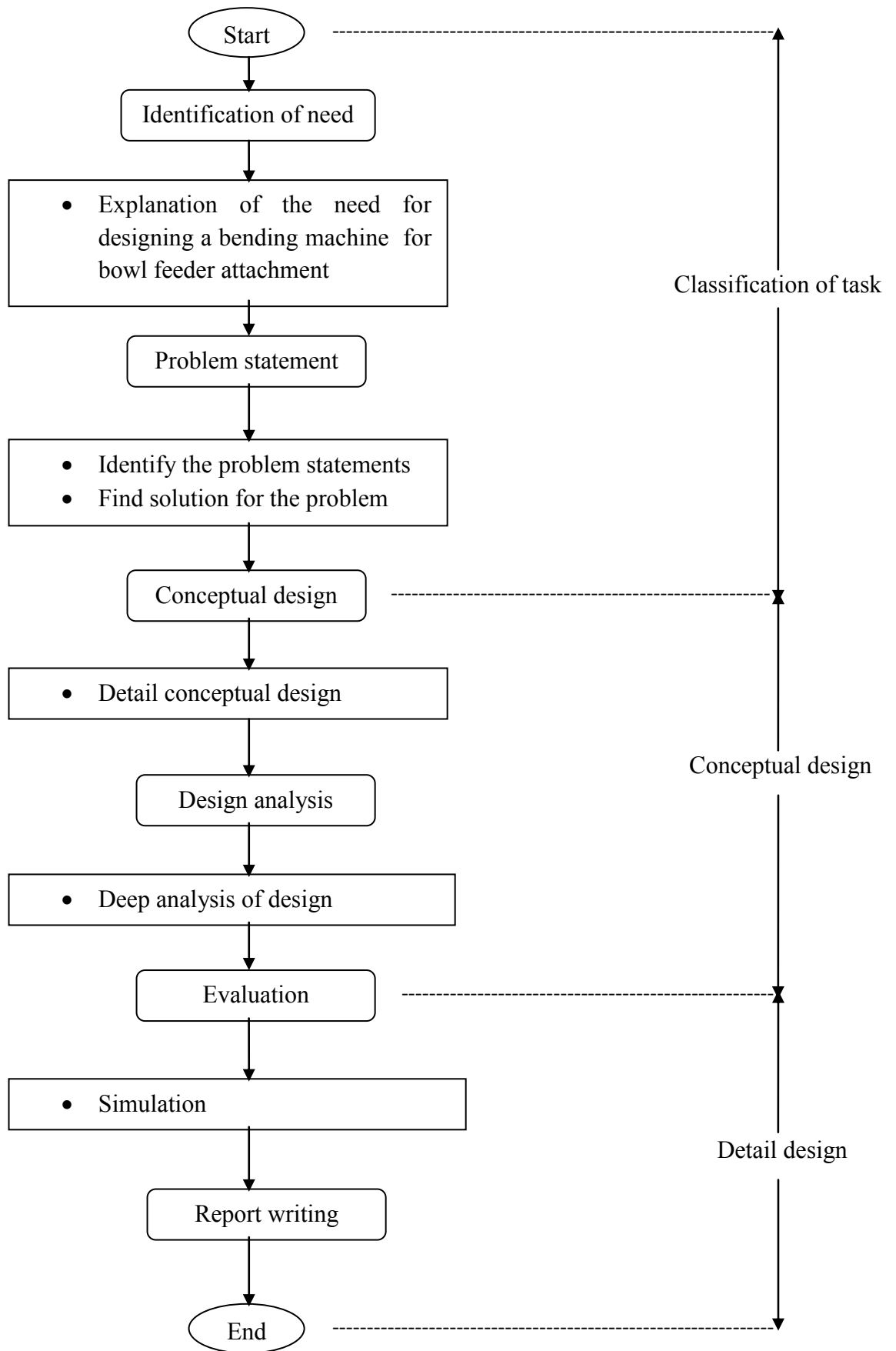

Figure 1.3: Methodology

CHAPTER 2

LITERATURE REVIEW

2.1 Overview

A bowl feeder is widely use in automation industry. The purpose of bowl feeder is feeding parts into a machine. To make a bowl feeder, a bending machine is used. The attachment of the bowl feeder plays the role in productivity of producing products. Unfortunately, there is no proper bending machine to bend a sheet metal for bowl feeder attachment. Moreover, the existing bending machine is big in size, consume a lot of space and it is use for big scale production. In this project, the literature review will discuss in detail in designing a bending machine, component features considered in designing a bending machine, etc.

2.2 Reasons to design a bending machine for bowl feeder attachment

The reason to design a bending machine for bowl feeder attachment is because there is no proper bending machine to bend a sheet metal for small scale. The bending machines found in the market come from variety of types. There are bending machine such as press brake bending machine, roll bending machine and a folding machine. Moreover, the design for the bending machine for bowl feeder attachment is to bend a sheet metal

in curve shape. Compare to the press brake bending machine, most product of the sheet metal is 90° bending. Same also to the folding machine, it produces sheet metal bending with desire degree of bending.

Other reason regarding to the bending machine design, the bending machine in the market come with big size and the bending machine is expansive. The existing bending machine in the market is created for huge capacity for bending a sheet metal. With the capacity of bending machine that exists in the market, the existing bending machine is not fulfilling the requirement of the usage. The requirement of operation of bending machine is simple. Thus it is not suitable to purchase existing bending machine to be used for simple bending machine operation. Moreover, the machine is heavy and use up a lot of space. In addition, the problem will arise when to move and put the bending machine due to heavy and space.

2.3 Existing bending machine

a) Press brake bending machine

Press brake bending machine use die and punch to bend a sheet metal. The die and punch of the bending machine have a variety of shape. Some of the common press brakes bending operations are bottoming, coining, air-bend, etc. Press brake bending machine is a machine that use motor to operate the bending machine. In addition, the press brake bending machine is come with big size and use a lot of space.

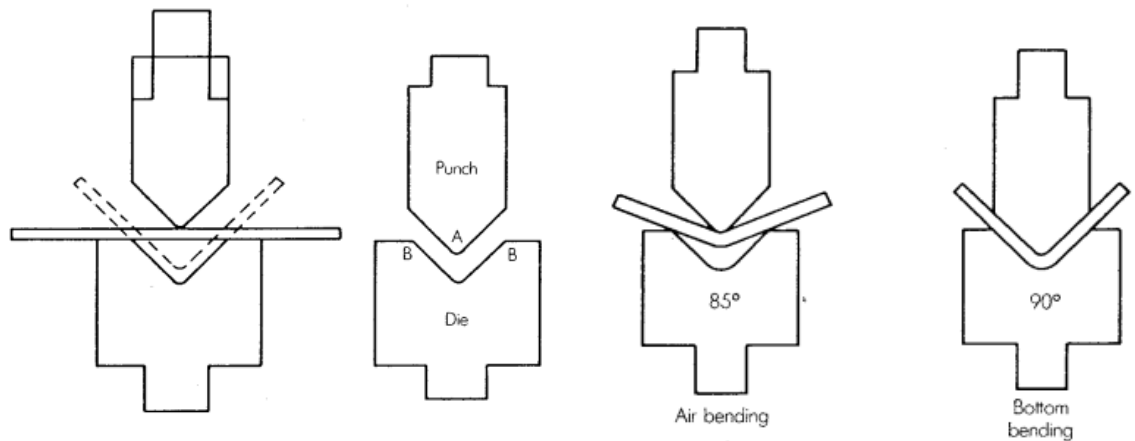

Figure 2.1: An example of air bending and bottoming, Wick C. et. al., Tool and Manufacturing Handbook Volume 2 (Forming), 4th Edition

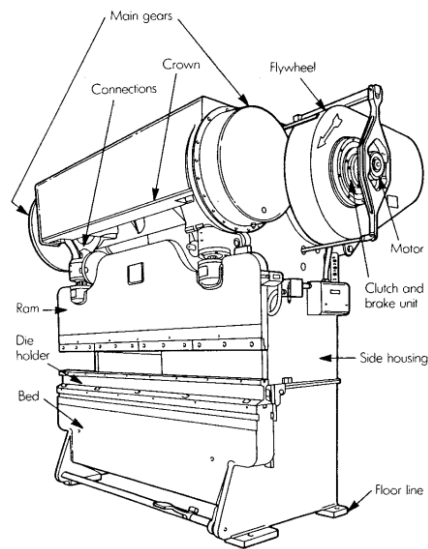

Figure 2.2: Illustration of press brake bending machine, Wick C. et. al., Tool and Manufacturing Handbook Volume 2 (Forming), 4th Edition

b) Roll bending machine

A roll bending machine uses roller to bend a metal. The roller of bending machine can be two rollers, three rollers, or four rollers. The common product of roll bending machine are tube bending, plate bending and a coil. All modern roll bending machine is power driven and some of the bending machine equip with electronic control for more