

BULLETIN@ RICE@UTeM

Research, Innovation, Commercialisation and Entrepreneurship

Wild Ideas: The Conduct of Ethical Research

INDUSTRY AND INTERNATIONAL RESEARCH COLLABORATIONS



Melaka Smart City Initiative Will Create Right Ecosystem

RESEARCHER'S ACHIEVEMENT



The Winning Research Products in the 30th ITEX 2019

RESEARCH AND INNOVATION HIGHLIGHTS

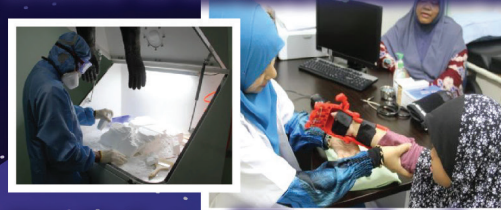

3D Printed Prosthetic Bionic Hand Project



Editorial Board

Patron

Prof. Dr. Zulkifilie Ibrahim

Advisor

Prof. Ir. Dr. Marizan Sulaiman

Chief Editor

Assoc. Prof. Ts. Dr. Massila Kamalrudin

Deputy Chief Editors

Assoc. Prof. Dr. Safiah Sidek

Assoc. Prof. Dr. Mohd Shahrieel Mohd Aras

Faculty Editors

Ir. Dr. Anas Abdul Latiff - FKEKK

Assoc. Prof. Dr. Mohd Shahrieel Mohd Aras - FKE

Dr. Siti Hajar Sheikh Md Fadzullah - FKM

Ruzy Haryati Hambali - EKP

Assoc. Prof. Ts. Dr. Sabrina Ahmad - FTMK

Dr. Nurulizwa Abdul Rashid - FPTT

Ts. Dr. Ahmad Fuad Ab Ghani - FTKMP

Mohamad Haniff Harun - FTKEE

Dr. Samer Ali Hussein Al-Shami - IPTK

Publication Editors

Nurhafidz Abdul Sahak

Fatonah Salehuddin

Faradila Md Yusof

Secretariats

Azhar Mohd Salleh

Siti Nadiah Othman

Printed & Published in Malaysia

Penerbit Universiti,

Aras Bawah, Perpustakaan Laman Hikmah,

Universiti Teknikal Malaysia Melaka

Hang Tuah Jaya, 76100 Durian Tunggal, Melaka.

Tel: +606 270 1241

Contents

Editor's Note	i
Wild Ideas	1
Industry and International Research Collaborations	2
Researchers' Achievements	7
Research and Innovation Highlights	8
New Book Release	17



Editor's Note

Assalamualaikum and Greetings,

Welcome to our 9th issue of RICE@UTeM bulletin for 2019. Thank you to those who have contributed to this issue and share your achievements in research and commercialization. This bulletin acts as an avenue for us to share our achievements in research and commercialization.

In this issue, our Deputy Vice Chancellor, Prof. Dr. Zulkifilie shared with us his wild ideas on ethical research. We are also proud to announce the achievements of our researchers in the ITEX 2019, the participations of our researchers in the prestigious international research grants and collaborations with the industry and state government. Further, in the research highlight section of this edition, we have included a list of interesting works by our researchers.

We would like to document more research discoveries and achievements in the next edition, so please send us your interesting research findings or experience to be included in the next issue of this bulletin. We are looking forward to expand the scope of the RICE bulletin to make it more interesting and beneficial for the readers; hence, we would love to hear from you.

Best regards and enjoy reading

Thank you.

Assoc. Prof. Ts. Dr. Massila Kamalrudin
 Chief Editor

Wild Ideas: The Conduct of Ethical Research



Conducting research is the bread and butter for academic researchers. We are expected to be actively involved in research work. In fact, our yearly performance is measured based on our active participation in research. Realizing the importance of conducting research in our daily practice, I would like to take this opportunity to remind researchers three important points in conducting research. Firstly, it is our obligation to ensure that the research is conducted with honesty. Research is a public trust. We are entrusted with the public money to find possible solutions for the problems we highlighted in our research proposal. Hence, we have to avoid ourselves from committing to 'scientific fraud', which involve the intention of manipulating, falsifying or plagiarizing during the conduct or reporting our research work.

Secondly, it is also important to be an efficient researcher. This means that we need to deliver what we have promised as reflected in the KPIs of the research. We have to carefully abide to the rules and regulations of the Bursary when spending the research grant and ensure that we complete the research project on time.

YBhg. Professor Dr. Zulkiflie Ibrahim
**Deputy Vice Chancellor
(Research and Innovation) UTeM**

The third point is related to the output of the research. It is time for researchers to consider the output of the research, be it a discovery of new knowledge or an innovative product contributes to the benefits of the community or the society at large. In other words, besides looking for opportunities for commercialization, researchers should also consider the possibilities of the new knowledge or innovative product to be transferred to the community for the purpose of improving the well-being of the society. Researchers should engage in research projects that have significant impact on the economy, providing revenues for the university, creating new businesses and new jobs for the community as well as improving quality of life.

All in all, I would like to advice researchers to conduct research with ethics and integrity and to produce research output that not only has commercial potentials but also beneficial to the community and society.

Finally, I would like to wish Happy Eid to all of the research communities in UTeM. May this Eid gathers all the happiness to all.

Congratulations

We would like to congratulate
Prof. Dr. Raha Abdul Rahim
for her appointment as the new
Vice Chancellor of UTeM.

Thank You

We also would like to express our sincere appreciation to
Datuk Prof. Ts. Dr. Shahrin bin Shahib
for his contributions during his tenure as the Vice-Chancellor of UTeM.
Thank you Datuk Prof.

Melaka Smart City Initiative Will Create Right Ecosystem

By: Dr. Yogan A/L Jaya Kumar, FTMK



Smart IoT Roundtable 2018 chaired by YB. Khoo Poay Tiong, Melaka Smart City Advisory Council and Co-Chairman Prof. Ts. Dr Goh Ong Sing, Assistant Vice-Chancellor, Industry and Community Network, UTeM.

MELAKA: Inspired by the national agenda on Industry Revolution 4.0, Universiti Teknikal Malaysia Melaka (UTeM) is working closely with the Melaka State Government to transform the state into a smart city, providing a tech-savvy population with a more efficient, safer, smarter and greener environment. A Smart City Advisory Council was formed by the state government in 2018 to play a key role to ensure more people-oriented projects were implemented by the council. According to Melaka Chief Minister YAB Adly Zahari, the establishment of the council managed by the State Economic Planning Unit (UPEN) would draw up policies and find ways to transform Melaka into a smart city, including the application of intelligent elements in state administration.

Among the elements proposed are the use of smart technologies, such as IoT water management systems, mobile management tools, smart energy grid, improved operational efficiency and urban services, thereby reducing energy and water consumption, reducing traffic congestion (and subsequently carbon emissions) as well as improving waste management. The chairman of Smart City Advisory Council, YB Khoo Poay Tiong said new ideas were needed for Melaka to be on a par with other historical cities. Thus, he encourages universities to work with the state government as their contributions can help Melaka reach its goal of becoming a smart city.

On Dec 17, 2018 UTeM hosted the Smart Internet of Things (IoT) Roundtable meeting at the Technology Campus in Ayer Keroh. The Roundtable meeting brings together representatives from the state government, industries, universities and local communities to present, discuss and take steps towards making Melaka a better and smarter place for living. YB Khoo, who chaired the meeting, encouraged local industries to submit their ideas and proposals on how they could help transform the state for a better city.

**..we should invest our time and efforts in our students to empower the next generation of innovators, ”
Goh Ong Sing**

Concurrent to the Smart IoT Roundtable Meeting, UTeM also hosted the Melaka Smart City Challenge Finale on Dec 17 at Samsung IoT Academy, UTeM. This program was co-organised by institutions of higher learning (IHL) based in Melaka, including Multimedia University (MMU), Universiti Teknologi MARA (UiTM), Universiti Kuala Lumpur (UniKL), Islamic University College of Melaka (KUIM), Politeknik Melaka and Politeknik Merlimau. The aim of the competition was to promote innovative projects to solve real-world problems and challenges, specifically the use of IoT as practical solutions to address the challenges in making Melaka a smart city. Besides, the program also aimed to discover talents in product development, research and commercialization. The competition was opened to all engineering, computer science, IT and science students from IHLs in Melaka.

According to UTeM’s Assistant Vice Chancellor (Industry and Community Network) Prof Ts. Dr Goh Ong Sing, the Smart City Challenge should be made as Melaka annual event. “As IoT-related technologies become more popular, it is our hope to give the next game-changing innovators or students the tools needed and the access to opportunities using IoT. We should invest our time and efforts in our students to empower the next generation of innovators, ” said Goh.

Moving forward, the collaboration between Melaka State Government and UTeM has established the ‘Melaka Artificial Intelligence of Things’ (MAIoT- <https://maiot.academy/>) platform in an effort to create a sustainable ecosystem and to support the advancement of digital technology. Melaka Communications, Multimedia, NGO, Youth and Sports Exco, YB Kerk Chee Yee said, the platform would be a medium to produce highly skilled or talented people in technology who are interested and committed to contribute to the development of the state through Artificial Intelligence (AI) and IoT.



Participants of the Smart IoT Roundtable Meeting, represented by private companies, industrial, institutions of higher learning, NGOs and Government agencies, such as Melaka Smart City Council, Samsung Malaysia Electronics, Intel, Malaysian Communications and Multimedia Commission (MCMC), Xinyi Class, Jabatan Kemajuan Orang Asli (JAKOA), Malaysia Productivity Corporation (MPC).

UTeM Researcher Secures ERASMUS+ “Engineering Knowledge Transfer Units to Increase Student’s Employability and Regional Development” (UNITED) International Project Grant by European Union (EU) for Capacity Building in Higher Education.

By: Dr. Muhd Ridzuan Mansor, CArE, FKM

The ERASMUS+ program is a prestigious international funding scheme by European Union (EU) to support activities in the fields of Education, Training, Youth and Sport. In November 2017, the Universiti Teknikal Malaysia Melaka (UTeM)’s research members from the Centre for Advanced Research on Energy (CArE) and Advanced Manufacturing Centre (AMC) led by Prof. Dr. Noreffendy Tamaldin have taken the initiative to collaborate with multi-country research partners to bid for the ERASMUS+ funding under the Capacity Building in Higher Education theme. The consortium is led by Joanneum University of Applied Sciences (FH Joanneum) from Graz, Austria, and consisted of eight (8) other partners from six (6) countries, which are FH Aachen (Germany), Politecnico Di Torino (Italy), Universiti Teknikal Malaysia Melaka (Malaysia), Universiti Putra Malaysia (Malaysia), Chulalongkorn University (Thailand), Mahasarakham University (Thailand), Universitas Sumatera Utara (Indonesia), Universitas Udayana (Indonesia), Atipong Motor (Thailand) and DreamEDGE Sdn. Bhd. (Malaysia). The list of the selected consortium partners are from nine (9) higher education institutions and two (2) prominent automotive industry players. The consortium has put in the bid on the “Engineering Knowledge Transfer Units to Increase Student’s Employability and Regional Development” (UNITED) as the focus topic for the ERASMUS+ international project grant.

After going through vigorous and lengthy evaluation process by the EU, the approval on the proposed UNITED project was finally obtained in January 2019. It was a great success especially to both UTeM and the UNITED consortium, as it was one of the 147 approved projects under the ERASMUS+ program among the 874 total project proposals submitted. Among the focus of the UNITED projects is to close the current lack of skilled labor on automotive engineering (AE) as well as to increase the positive impact of the automotive industry on regional development. The project will be carried out through the execution of expert trainings for academic staff, students and companies interested in AE, including training on project financing methods. It is expected that all parties involved will be able to participate in many initiatives in the future. Furthermore, the UNITED project will also involve in the installation of testing bays, which will lead to increased knowledge on AE, higher



Figure 1: Group photo during 1st kick-off meeting of ERASMUS+ UNITED project at FH Joanneum, Graz, Austria on 9th - 18th March 2019.



Figure 2: Representatives from UTeM during the 1st kick-off meeting of ERASMUS+ UNITED project at FH Joanneum, Graz, Austria on 9th - 18th March 2019 (from Left: Prof Dr. Noreffendy Tamaldin, Prof Dr. Ghazali Omar and Dr. Muhd Ridzuan Mansor)

that amount, UTeM has been allocated Euro 87,658.00 (approximately RM 412,000.00) to execute and lead one of the key work packages under the UNITED program. The UTeM team members involved in this UNITED project are Prof. Ts. Dr. Noreffendy Tamaldin (UTeM project leader), Assoc. Prof. Dr. Mohd Fadzli Abdollah, Dr. Ahmad Kamal Mat Yamin, Dr. Nor Azmmi

standards in teaching, higher employability of graduates and more university-business cooperation through the operation of six (6) competence centers (Engineering Knowledge Transfer Units) on AE in Indonesia, Malaysia and Thailand attached to the testing bays. Knowledge dissemination shall also be carried out through special conference organized under the UNITED project.

The approved ERASMUS+UNITED project will be carried out over a period of 36 months, with the total grant allocation of Euro 980,841.00 (or approximately RM 4,511,870.00). Within

Masripan, Ts. Dr. Muhd Ridzuan Mansor, Ts. Dr. Mohd Azli Salim (members from CARE UTeM), Prof. Dato' Dr. Abu Abdullah, Prof. Dr. Ghazali Omar, Assoc. Prof. Dr. Md Nizam Abd Rahman and Assoc. Prof. Dr. Mohd Rizal Salleh (members from AMC).

The success of securing the ERASMUS+ UNITED grant has proven the capability and competency of UTeM's researchers in collaborative international research activities, especially in the field of automotive engineering (AE), both to European and ASEAN counterparts. UTeM's participation in the ERASMUS+ UNITED project shall also



Figure 3: Working visit by ERASMUS+ UNITED partners to Magna Steyr, one of Austria's automotive leading player production facility, at Graz, Austria

give valuable advantages to all researchers and students in terms of international visibility and further networking opportunities, as well as contributing in scoring high merits in Malaysian Research Assessment (MyRA). It is hope that this pioneering UNITED project will pave ways for UTeM's researchers to participate and secure more international collaborative research projects in the future, especially from the EU as well as other prominent grant providers worldwide.



Figure 4: Working visit by ERASMUS+ UNITED partners to Pankl Racing production facility, which manufacture high performance automotive components, at Graz, Austria

IEEE Oceanic Engineering Society (OES) Malaysia Industry Advisory Group

By: Assoc. Prof. Dr. Mohd Shahrheel Mohd Aras, CeRIA, FKE

A Lunch Meeting with the IEEE Oceanic Engineering Society (OES) Malaysia Industry Advisory group was held on Wednesday 17th April 2019 at the Eatatlevelsix Restaurant, the Regency Scholar's Hotel Kuala Lumpur. The objectives of the lunch meeting were to share and discuss current issues related to underwater and subsea services, ocean and hydrographic survey, offshore support services and Marine engineering and civil services in Malaysia. One of the agenda in the meeting was to discuss the latest technology related to IR 4.0, current projects and potential collaborations with the universities. The lunch meeting involved four companies and three universities related to oceanic engineering and maritime. The four companies were the Fugro Geodetic (Malaysia) Sdn. Bhd., Temasek Hidroteknik Sdn. Bhd., MTC Engineering Sdn. Bhd. and Efogen Sdn. Bhd. Meanwhile, the universities involved were the Universiti Teknikal Malaysia Melaka (UTeM), Universiti Sains Malaysia and Universiti Teknologi Malaysia. In the meeting, Assoc. Prof. Dr. Mohd Shahrheel Mohd Aras and Assoc. Prof. Dr. Ahmad Anas Yusof represented UTeM. Additionally, the Vice Chair and Executive Committee for IEEE OES Malaysia Chapter 2019 were also present in the meeting.



The meeting has given the opportunities for the universities to collaborate in research activities that are aligned with the needs of the industries. Most the industries members of this society are willing to share their experience in an industry talk and collaborate with universities for research grants. They also welcome any academic staff interested in Industrial Attachment. From this meeting, one of a companies, Temasek Hidroteknik is willing to sponsor the Malaysia AUV Challenge 2019 at UTeM in December 2019.

The 30th International Invention, Innovation and Technology Exhibition (ITEX) 2019 organized by the Malaysian Invention and Design Society (MINDS) with the support from the Ministry of Education (MOE) and the Ministry of Science, Technology and Innovation Malaysia (MOSTI) was held in Kuala Lumpur recently. UTeM has successfully won four gold medals and nine silver medals. The list of winning research products and their respective principal researchers and the center of excellence is presented below. Congratulations UTeM's researchers!

The Winning Research Products in the 30th International Invention, Innovation and Technology Exhibition (ITEX) 2019

NO.	PRODUCT NAME	PRINCIPAL RESEARCHER	COE	MEDAL
1	MUETLex	Dr. Noorli binti Khamis	CTED	GOLD
2	A Blessing From Natural for Superlight & Durability - Paintball Tactical Armour Vest	Assoc. Prof. Ir. Ts. Dr. Mohd Yuhazri bin Yaakob	AMC	GOLD
3	Ceram C_Tool	Assoc. Prof. Ir. Dr. Hadzley bin Abu Bakar	AMC	GOLD
4	Pico Hydro Generation System for Low Head Low Flow Water Resources	Ir. Dr. Mohd Farriz bin Basar	CERIA	GOLD
5	Nanoscale Graphene for Future Super Conductive Materials	Ts. Dr. Mohd Azli bin Salim	CARE	SILVER
6	Postnatal Pain Reliever	Dr. Mohammad Kamil bin Sued	AMC	SILVER
7	Design, Optimization and Fabrication of 3D Printing Orthopedic Calf Cast	Mohammad Rafi bin Omar	CARE	SILVER
8	Dual-Band Aperture Coupled Rectenna for RF Energy Harvesting	Dr. Maizatul Alice binti Meor Said	CETRI	SILVER
9	Synthesis of Graphene from Waste Products	Dr. Mohd Rody bin Mohamad Zin	CARE	SILVER
10	Development of Customized Pes Planus (Flat Foot) Orthotic Insole Using Additive Manufacturing	Dr. Zulkeflee bin Abdullah	AMC	SILVER
11	Eco-Helmet (Ecol) "Safety from Nature"	Assoc. Prof. Ir. Ts. Dr. Mohd Yuhazri bin Yaakob	AMC	SILVER
12	Uniaxial Cyclic Bending Test Apparatus for Flexible Printed Electronics Reliability Assessment	Dr. Muhd Ridzuan bin Mansor	CARE	SILVER
13	Learn-With0iman App: Interactive Children Educational Mobile Application Using Machine Learning for Image Recognition	Noor Mohd Ariff bin Brahin	CETRI	SILVER



3D Printed Prosthetic Bionic Hand Project

By: **Mohammad Rafi Omar, JTKM, FTKMP**



Researchers from the Faculty of Mechanical and Manufacturing Engineering Technology (FTKMP), Universiti Teknikal Malaysia Melaka (UTeM) have

successfully produced an innovative product named the 3D Printed Prosthetic Bionic Hand. The function of this innovative product is to help those with finger disabilities to live a better life. This 3D Printed Prosthetic Bionic Hand was donated to Khairunnisa Umairah Mohd Sabri a year two student from 2 Hasan, Sekolah Rendah Islam (SRI) Annuriah Addiniah, Sungai Udang, Melaka who has a finger defect since birth.

This 3D Printed Prosthetic Bionic Hand donation project is a collaboration between the Faculty of Mechanical and Manufacturing Engineering Technology (FTKMP), Faculty of Electric and Electronic Engineering Technology (FTKEE), UTeM Health Centre and Sekolah Rendah Islam (SRI) Annuriah Addiniah, Sungai Udang, Melaka. Umairah's father, Mohd Sabri from Bukit Rambai Melaka, said the contribution of the 3D Printed Prosthetic



Bionic Hand has successfully given a new brighter future for his daughter. It has cheered her up and boosted her self-esteem when she interacts with her school friends. He also expressed his gratitude and appreciation to UTeM who has succeeded in producing an innovative product that gives great benefit to his daughter.



The designer of this product, Mohammad Rafi Omar explains the idea to design this 3D Printed Prosthetic Bionic Hand was facilitated by an open source internet that allows him to share the design in cyberspace. According to him, the design was done using CATIA V5 software, and it was then shared with UTeM research team to redesign it according to the size of Umairah's hand. The design process involved the application of the latest technology in UTeM in line with the

development of the Industrial Revolution 4.0. The STEINBICHLER T-TRACK LV 3D scanner was used to scan Umaira's hand to get the actual size. The lifting strength of the 3D printed prosthetic bionic hand was tested using simulation software. This prosthetic bionic hand was printed by FARSOON 402 Selective Laser Sintering (SLS) 3D printer.

This project was the result of collaboration and hard work of seven other UTeM researchers, Mohamad Azrul Mamat, Muhammad Nur Othman, Arman Hadi Azahar, Shahrizan sultan, Rabani Abd Rashid, Mohd Khairil Zulkhaini and Zahirul Za'im Samin.

Bias and Variance Trade-off in Information Criterion for System Identification

By: Ir. Dr. Md. Fahmi Abd Samad @ Mahmood, CARE, FKM

For long, there has been a polemic over the issue of suitable balance between bias and variance when it comes to choosing a system's model. In system identification, the selection of a model structure to represent a system consists of four main steps, which are data acquisition, model structure selection, parameter estimation and model validation [1]. Model structure selection refers to the determination of the variables and terms to be included in a model. The criteria in describing an optimum model for a system are basically having adequate predictive accuracy to the system response and parsimonious in structure (Figure 1). A model is preferred as a parsimonious model structure since it has less number of variables and/or terms, hence making the system analysis and control becomes easier. In this case, the terms bias and variance of model structure are considered two very important aspects for deliberation.

The two crucial characteristics of a model structure are the model accuracy and the model parsimony. To compare among the choices of model structures for the selection of the optimum structure, one resorts to an evaluation of these structures based on mathematical formulation, known as information criterion (also called loss function or objective function). Two components are common in an information criterion - variance and bias: $f(J) = \text{Var}(J) + \text{Bias}(J)$, where $f(J)$ is the information criterion, $\text{Var}(J)$ is the variance, which is the maximized value of the likelihood functions for the estimated model and $\text{Bias}(J)$ is the penalty term that penalizes complexity of the model.

Traditionally, a model structure selection is performed by determining a finite set of models, typically within a certain maximum specification, and enumeratively testing the models for predictive accuracy and parsimony. The decision of selection is based on certain information criterion, although other methods such as backward elimination, forward selection or inclusion and stepwise regression method are available. Furthermore, a more recent method called orthogonal least squares can also be found. According to Almpandis and Kotropoulos, three principles that regulate the ability to make inferences are parsimony, working hypotheses and strength of evidence [2]. Information criterion approaches adhere in part to all these concepts, which make them more attractive than classical pairwise significance testing. Variance term penalizes the inaccuracy of the model and bias term provides a penalty for model complexity. The lower the variance term, the higher the accuracy of the model. But, the idea to select the model with the smallest variance term within the set is not a good idea because when more parameters are added, it will continue to decrease and the model becomes complex.

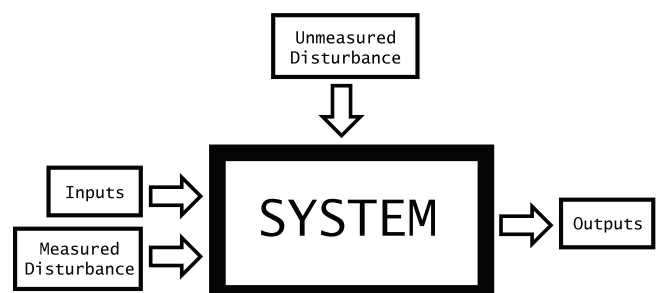

As most common ones, both Akaike information criterion (AIC) and Bayesian information criterion (BIC) have a straightforward implementation and yield reasonable results. The theoretical idea of AIC is based on Kullback-Leibler information and maximum-likelihood estimation theory, while BIC is developed from Bayesian arguments and it is related to Bayes factors. Another information criterion is known as parameter magnitude-based information criterion (PMIC), and later developed into PMIC2 [3]. Figure 2 provides a guide on how an information criterion may be developed.

Although there is not much difference on how an accuracy of a model (variance consideration) is evaluated among these information criterion, AIC and BIC were developed for a general class of problems such that they require information on the number of samples and parameters, whereas PMIC2 account for individual term significance by the magnitude of parameter, to allow the bias of having many variables be further penalized towards selecting a parsimonious model. It is then on the hand of the user to further judge the strengths and weaknesses of these information criterion and make the right selection for the optimum model.

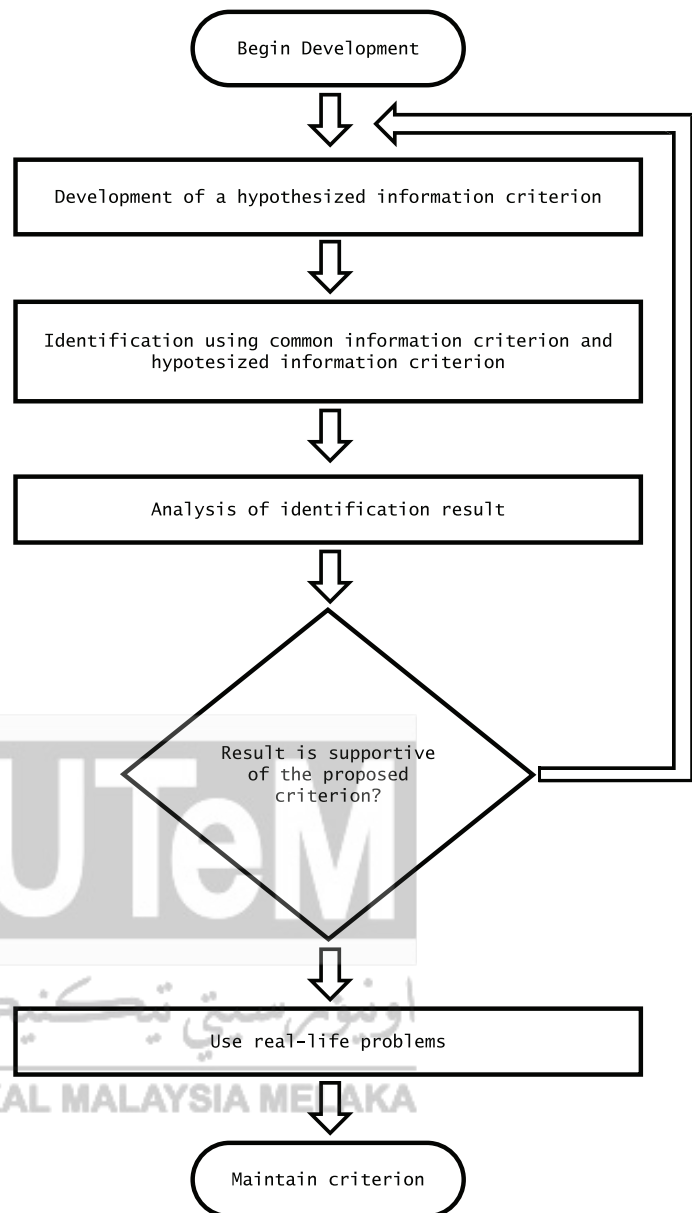

References:

[1] Keesman, K.J. (2011). System Identification: An Introduction. Springer-Verlag London.
 [2] Almpandis, G. and Kotropoulos, C. (2008). Phonemic Segmentation using The Generalized Gamma Distribution and Small Sample Bayesian Information Criterion. Speech Communication, 50(1), pp. 38-55.
 [3] Samad, M.F.A. and Nasir, A.R.M. (2018). Implementation of Parameter Magnitude-Based Information Criterion in Identification of a Real System, Defence S&T Technical Bulletin, 11(1), pp. 99-106.

Personal Remote Sensing System (PRSS)

By: Assoc. Prof. Gs. Dr. Asmala Ahmad, Mohd Yazid Abu Sari, C-ACT, FTMK

Remote sensing has long been dependent on satellites and aircrafts that are operated by government agencies worldwide, such as NASA (USA), ESA (Europe), NRSA (India), JAXA (Japan) and ARSM (Malaysia) due to the expensive infrastructures. Consequently, remote sensing data users do not just pay high cost for the data but also have limited choices of spatial, spectral and temporal resolution of the data. This has become a problem for users particularly small groups or individuals who intend to use remote sensing system to fulfil their daily tasks. To overcome these issues, Personal Remote Sensing System (PRSS) has been developed. PRSS can be operated by one person, from anywhere and at any time. It can be customized based on user's desired spatial, spectral and temporal resolution. Figure 1 shows

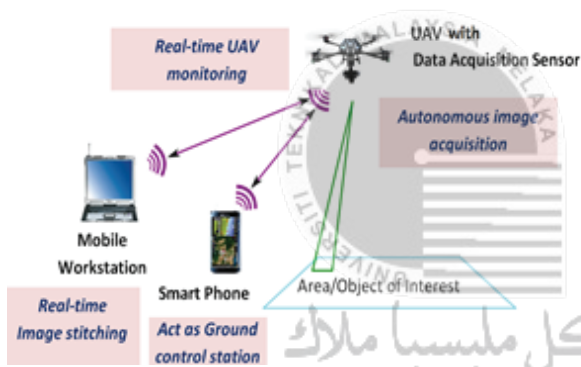

Figure 1: PRSS operational concept.

the concept of PRSS in which the main components are a multirotor UAV, smart phone and workstation. The system can be triggered from a smart phone that acts as the ground control station. Figure 2 shows a close-up of the UAV component, which is foldable and can be easily carried by hand. The UAV can navigate autonomously and track in real-time. Images are captured and transmitted from a sensor (camera)

mounted on the UAV to a workstation via

Wi-Fi. These images are to be stitched and stored in the workstation for subsequent analysis.

Among others, PRSS can be used for various geospatial analytics purposes such as urban planning, digital surface modelling, 3D modelling, road planning, crack detection, agricultural management, sedimentation monitoring and environmental management as shown in Figure 3. In urban planning, with high quality aerial view, buildings and infrastructure location suitability can be efficiently examined. High accuracy digital surface models can be generated due to the very high spatial resolution of the images. 3D models of buildings are able to be constructed by autonomous navigation of the UAV around the buildings while capturing images. In road planning, blind spots can be detected and highlighted for further



Figure 2: A close-up of the PRSS UAV component.

actions. Crack detection is also possible with the mm level of the image spatial accuracy. In agriculture sector, soil levelling and vegetation condition can be effectively monitored for further improvement. In coastal areas, sedimentation issues can be monitored and managed effectively using suitable multi-temporal images. In environmental management, land uses can be examined and analyzed to ensure they follow the specified regulations. In conclusion, PRSS is a low-cost alternative that is not just offering remote sensing autonomy to users but also able to help companies and individuals in implementing their daily tasks effectively.

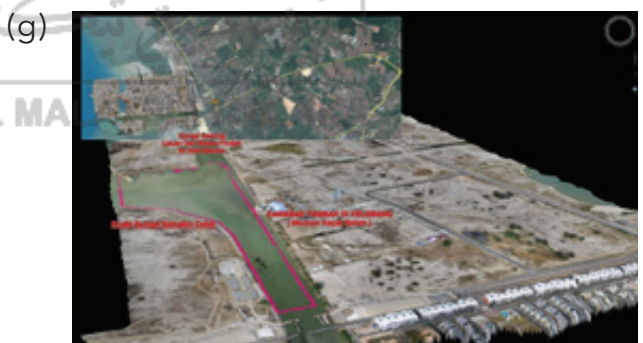
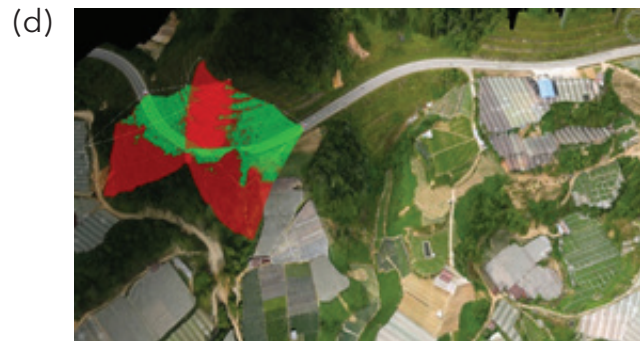
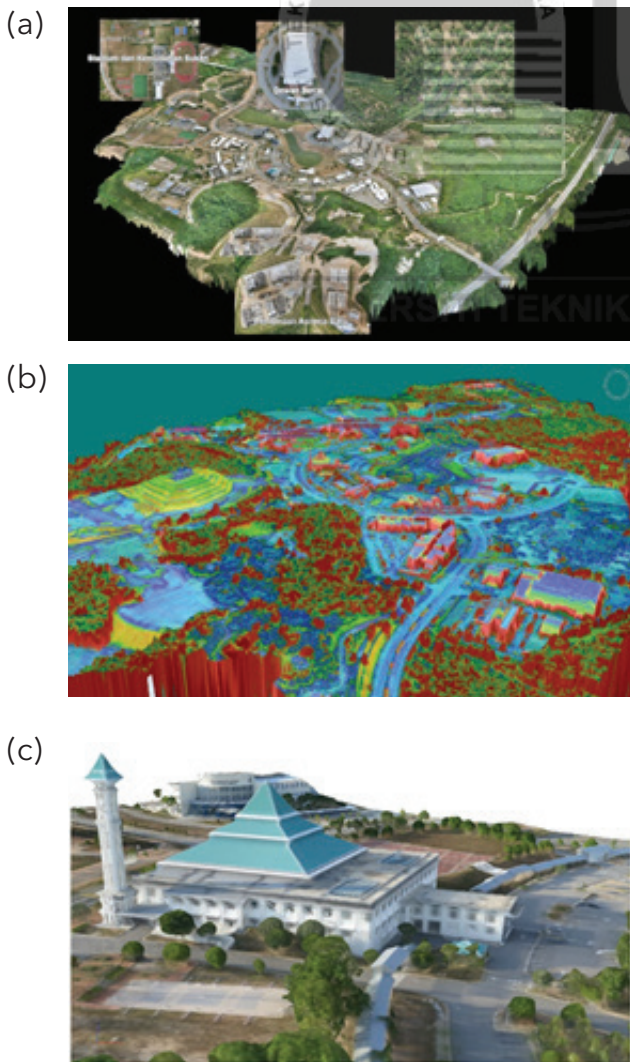

Figure 3: Applications of PRSS: (a) urban planning, (b) digital surface model (dsm), (c) 3d modelling, (d) road planning, (e) crack detection, (f) agricultural management, (g) sedimentation monitoring and (h) environmental management.

PV and Wind Hybrid Monitoring System for UTeM Renewable Energy Showcase

By: Alias Khamis, CeRIA, FKE

Renewable energy sources have become a popular alternative electrical energy source due to the lack of practicality of the power generation conventional method. Hence, the renewable energy source and its intermittent in nature cannot be predicted. Due to these reasons, this energy source requires a monitoring system to ensure the consistency of the system performance to run well. This monitoring system provides a continuous measurement of generated power of PV and wind hybrid system through DAQ. The objectives of this project is to analyze the output performance of desired parameters generated by PV and wind hybrid system using DAQ NI 6008 device. Two methods used to monitor the hybrid system are the software implementation and hardware implementation.

The sensors were connected to analog input port in the DAQ device, in which the DAQ device processed the signal and connected it to a computer via USB, before the hardware connection was initialized. This experiment shows the results of voltage, current and power of PV and wind hybrid system using LabVIEW simulation, which used Hybrid Solar Wind Street light hardware located in FKE. The results showed the DAQ device was able to record and analyze data in real-time mode that continuously based on the desired parameters.

Based on the results, a DAQ device is able to record and analyze the data of desired parameters, which are the voltage, current and power in real-time mode and continuously through the LabVIEW simulation. For future work, this system will integrate with IoT technology where it can be monitored anywhere. This system is also suitable for Melaka that are moving towards smart city that has more efficient and tech-savvy population with safer environment.

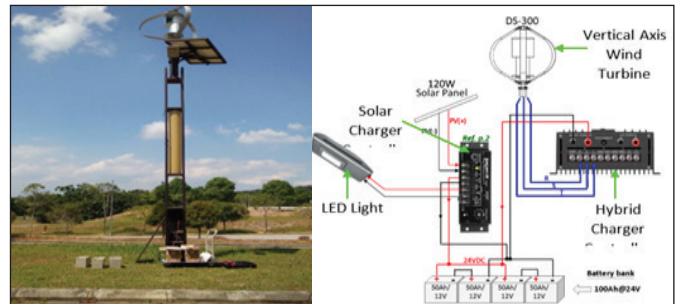

Figure 1: Hybrid Solar Wind Streetlight hardware and schematic diagram

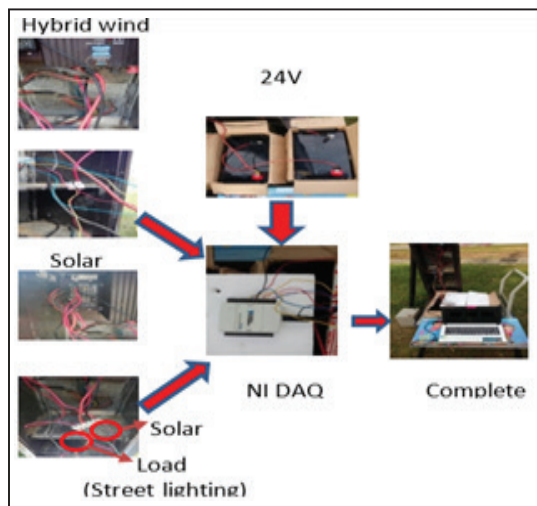

Figure 2: Sensors, load and battery are connected to DAQ

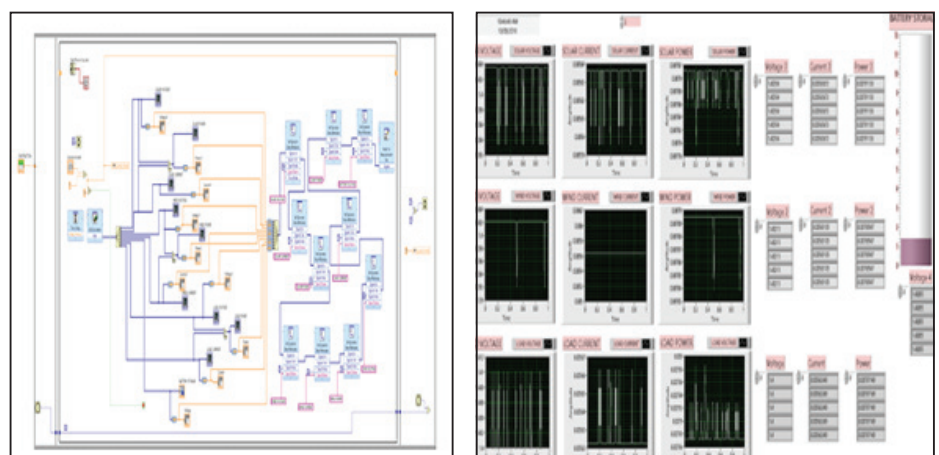

Figure 3: Block Diagram and Front Panel of PV-Wind hybrid monitoring system

Characterization of Copper Mechanical Properties Using I-Kaz 4D Analysis Method Via Piezofilm Sensor

By: Ts. Mohd Irman Ramli, JTKM, FTKMP

ABSTRACT – An alternative advanced statistical analysis method known as the I-kaz 4D or I-kaz 4 channels, which uses the sensor fusion concept by applying four sensors to collect the vibration signals excited by the impact hammer was introduced in this study. The study was carried out using copper (Cu). The specimens were in shape of circular, rectangular and square. The impact force was set with the range of different forces. Four piezofilm sensors were placed at the specimen’s surface to observe and record the vibration signal after the impact. The obtained results were compared with the results obtained by I-kaz 4D method.

INTRODUCTION

The present study deals with the use of the impact testing method to produce an excitation within the metallic material specimen. Although this method is a relatively simple technique to implement, there are challenges in obtaining the symmetric results. The most important feature of the present method is that it does not require a complex and expensive machines. It only needs some hardware, which makes this technique very attractive and convenience. The implementation process consists of the impact hammer, analyzer and software. A piezoelectric sensor was used to monitor the vibration signal of the specimen under the impulse excitation in order to analyze and determine its characteristic frequencies [1]. Further analysis was done on the observed vibration signals during the test impact and the possible correlation between these signals and the specific material properties were studied by digital signal analysis approach using the I-kaz 4D.

METHODOLOGY

The characterization of material properties in this study was based on the analysis of vibration signal resulting from the impact force from the impact hammer [2]. With the help of Labview software 2015, DAQ NI 9234 National Instrument data collection system, and Rion- Note multi-factional measuring system platform SA-A1 device, data input from impact hammer were processed, stored and analyzed. Two types of signals were observed by the developed software, i.e., the vibration signal from the piezofilm sensor and the impact force signal. Observations were carried out using appropriate equipment to measure the different types of signal. Next, an alternative method for signal analysis and interpreting signals were used. Figure 1 shows the schematic diagram of the experiment, while Table 1 shows the experiment components.

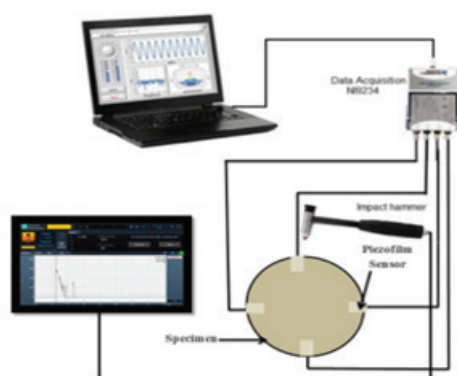

Figure 1: Schematic diagram of the experiment.

Table 1 Experiment components

Component	Specifications	Quantity
Impact hammer	D15 cm	1
The data acquisition device	NI 9234 (four-channel)	1
Signal Express software	Multichannel High speed	1
Rion SA-A1 device software	Multi-factional measuring system	1
Piezofilm sensor	SDT1- molded plastic	1
Specimen	Copper(Cu)	3
Supporter	polyurethane foam	3

I-kaz 4D using the direct fusion, where the data were collected from four homogeneous sensors. The formula of I-kaz 4D is as follows:

$$Z_{4D}^{\infty} = \frac{1}{n} \sqrt{k_1 s_1^4 + k_2 s_2^4 + k_3 s_3^4 + k_4 s_4^4}$$

Where Z_{4D}^{∞} : I-kaz 4D coefficient n : number of samples k : kurtosis s : standard deviation.

RESULTS AND DISCUSSION

Type of Signals

Two types of signal data simultaneously measured in the experiment, namely the signal of the impact force and vibration signal that were captured by the four piezofilm sensors for each of the circular, rectangular and square shapes

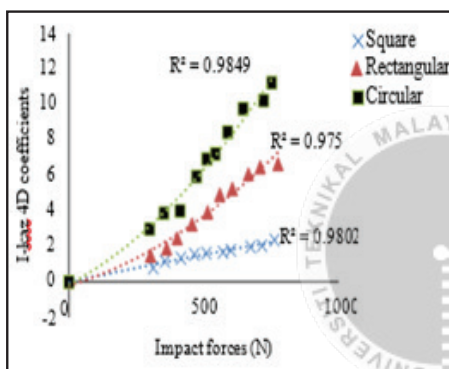

Figure 3: I-kaz 4D vs impact forces

was analyzed using FFT method. The two signals were generated during the process of impact between the impact hammer and the material specimens [3]. Figure 2 shows the vibration signal of copper. The vibration signals obtained from the impulse excitation experiment were analyzed using the newly developed statistical methods known as I-kaz 4D. The I-kaz 4D method, known as Integrated kurtosis-based

algorithm used four sensors simultaneously to record the vibration signals. In this method, the time domain of vibration signals that captured by the piezofilm sensors were analyzed to extract the information contained in the signal content. The statistical analysis of I-kaz methods is based on the concept of scattering data to a central value [4].

Correlation between Piezofilm Signals and Copper Mechanical Properties

To study the existence of correlation between the vibration signal and any of the mechanical properties of the metal materials of the three different shapes used in the experiment, the vibration signal recorded by the piezofilm sensor was analyzed by applying the I-kaz 4D statistical analysis method, which produced the I-kaz 4D coefficient. The pattern of changing in the magnitude of these I-kaz 4D coefficients with respect to the changing of the impact force

applied on the specimen for all shapes has been studied by plotting the I-kaz 4D coefficients of the piezofilm sensors. Figure 3 shows the graph obtained and Table 2 shows the data.

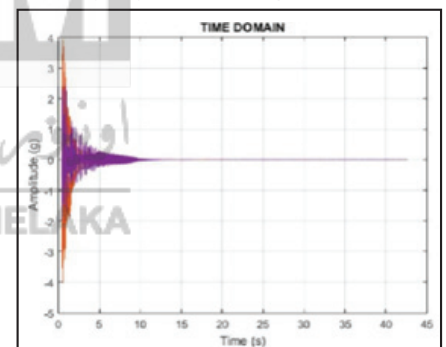

Figure 2: Vibration signal of circular copper at 300 N.

CONCLUSION

In this study, a method of characterization of the material properties using advance statistical analysis of vibration signal known as I-kaz 4D has been developed. Additionally, the dynamic response technique was used to compare its result with the result obtained when I-kaz 4D technique was used, wherein I-kaz method showed a significantly better results.

- [1] Bruno, L., Felice, G., Pagnotta, L., Poggiani, A. & Stigliano, G. (2008). Elastic characterisation of plates of any shape via static testing. *International Journal of Solids and Structure*, 45(3-4), 908-920.
- [2] Karim, Z., Izatul, H.A.R., Azuan, S.A.S., Mastura, S., Said, A.Y.M., Bahari, A.R., Ghani, J.A. & Nuawi, M.Z. (2013). Material mechanical property correlation study using vibration signal analysis. *Australian Journal of Basic and Applied Sciences*, 7(4), 94-99.
- [3] Ramli, M.I., Nuawi, M.Z., Abdullah, S., Rasani, M.R.M., Ahmad, M.A.F. & Seng, K.K. (2017). An investigation on light structure modal parameter by using experimental modal analysis method via piezofilm sensor. *Jurnal Teknologi*, 79(6), 159-165.
- [4] Ziyad, S.S., Nuawi, M.Z., Jasim, M.T., Bahari, A.R. & Nadia, F.M. (2015). Characterisation of polymer material using, I-kazTM analysis method under impact hammer excitation.



Sustainable
Responsive
Manufacturing

ISORIS'19

28-29 AUGUST 2019

International Symposium on RESEARCH in INNOVATION AND SUSTAINABILITY

Call for Posters

ABOUT THE CONFERENCE

The IS3, SUSREM and Universitas Islam Batik Surakarta (UNIBA) are proudly to announce the 2019 International Symposium on Research in Innovation and Sustainability (ISoRIS). IS3 (Innovative Software System and Services) and SUSREM (Sustainable an Responsive Manufacturing) are among research groups under UTeM Center of Excellence to lead research and innovation in Advanced Manufacturing and Computing Technologies (AMCT).

SCOPE

1. Sustainable Manufacturing
2. Smart Manufacturing
3. Innovative Software System
4. Software Engineering and other ICT applications
5. Social impact on innovation and ICT
6. Industrial Case Studies
7. Engineering and IT education for Sustainability
8. Entrepreneurship
9. Social Science and Community Study
10. Economics and Management

IMPORTANT DATES / FEES

PAPERS

- Full Paper Submission: 7 May 2019
- Notification of Acceptance: 15 May 2019
- Camera Ready: 15 June 2019
- Fees: 1st Author
 - USD450 (RM1800) for 1st paper
 - USD350 (RM1200) for 2nd paper
 - USD230 (RM900) for 3rd paper

POSTER/PRODUCT INNOVATION

- 2-page Submission: 9 June 2019
- Notification of Acceptance: 19 June 2019
- Camera Ready: 30 June 2019
- Fees: 1 poster/product: USD100 (RM400)

PUBLICATION

All **accepted and presented** full papers will be published in ISI@Clarivate/Scopus indexed journals whereas fo 2-page papers will be published in conference proceedings with ISBN.

Secretariat:
isoris2019@gmail.com

**INNOVATION for
GLOBAL Sustainability**

<http://isoris.org/isoris2019/>

**MERCURE PENANG BEACH HOTEL,
PENANG, MALAYSIA**

New Book RELEASE

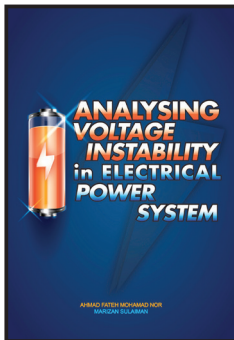

Title: **Analysing Voltage Instability in Electrical Power System**
Authors: **Ahmad Fateh Mohamad Nor & Marizan Sulaiman**
ISBN: **978-967-2145-28-8**
Price: **RM8.00**

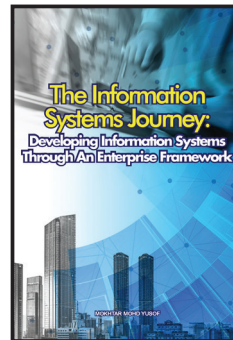

Title: **Developing Information Systems Through an Enterprise Framework**
Authors: **Mokhtar Mohd Yusof**
ISBN: **978-967-2145-28-8**
Price: **RM19.00**



Title: **Computing for the Community**
Authors: **Sabrina Ahmad & Nurul Akmar Emran**
ISBN: **978-967-2145-14-1**
Price: **RM9.00**

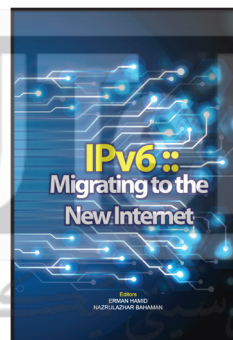

Title: **IPv6: Migrating to The New Internet**
Authors: **Erman Hamid & Nazrulazhar Bahaman**
ISBN: **978-967-2145-45-5**
Price: **RM10.00**

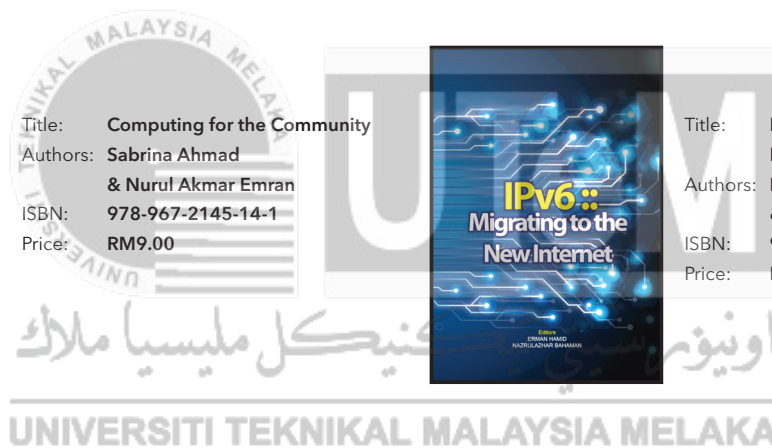

Title: **Game Design: Issues, Trend and Challenges**
Authors: **Ibrahim Ahmad & Nazreen Abdullasim**
ISBN: **978-967-2145-51-6**
Price: **RM28.00**

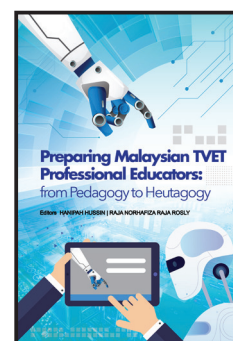

Title: **Preparing Malaysian TVET Professional Educators: From Pedagogy to Heutagogy**
Authors: **Hanipah Hussin & Raja Norhafiza Raja Rosly**
ISBN: **978-967-2145-46-2**
Price: **RM26.00**



Available now at:
<http://utembooks.utem.edu.my>



Penerbit UTeM



UTeM

اوتيم سيكولجيا ملقا

UNIVERSITI TEKNIKAL MALAYSIA MELAKA



اوتيم سيكولجيا ملقا
UNIVERSITI TEKNIKAL MALAYSIA MELAKA

www.utm.edu.my

PENERBIT UTeM Press

Website : www.utm.edu.my/penerbit

Books Online : utembooks.utm.edu.my

Email : penerbit@utm.edu.my