

RICE@UTeM

BULLETIN@

Research, Innovation, Commercialisation and Entrepreneurship

**OUTSTANDING
RESEARCH
PERSONNEL**

**TOTAL APPROACH IN
R&D MANAGEMENT**

**AWARD WINNING
RESEARCH PRODUCTS**



R&D

PERFORMANCE OF 2015

CONTENTS

EDITOR'S NOTE	2
OUTSTANDING RESEARCH PERSONNEL: Profesor Madya Dr Zahriladha Bin Zakaria	3
WILD IDEAS Total Approach In R & D Management	4
R&D PERFORMANCE OF 2015	5
ACHIEVEMENTS/ EVENTS Inaugural SEDA GCPV Wireman and Chargeman Certified Course at UTeM	7
SHOWCASE OF KUALA LUMPUR ENGINEERING SCIENCE FAIR 2015	8
A RESEARCH VISIT TO IBM TRIANGLE PARK, USA	8
UTeMEX 2015	9
24TH SCIENTIFIC CONFERENCE OF MICROSCOPY SOCIETY MALAYSIA (SCMSM2015)	10
SERIES OF TMAC 2015	11
1ST DESIGN WORKSHOP 2015	13
COMMERCIALISATION	14
RESEARCH HIGHLIGHTS	14
LEAN AND DATABASE MANAGEMENT	15
APPLICATION OF DEFECT DETECTION IN GLUING LINE USING SHAPE-BASED MATCHING APPROACH	16
ENERGY SAVING DEVICE A FAIRYTALE	17
KANSEI ENGINEERING APPROACH TO MEASURE RESPONSE IN HUMAN-ROBOT INTERACTION (HRI)	17
AWARD WINNING RESEARCH PRODUCTS	18
INTRODUCING A NEW RESEARCH GROUP Underwater Technology Research Group (UTeRG)	20



Dr. Massila Kamalrudin

Welcome to the 2nd edition of RICE. Unlike the first edition, this edition focuses on the overall achievements in research and innovation at UTeM In 2015. Alhamdulillah, overall, researchers of UTeM have done well in winning research grants, innovating and commercialising products.

In this edition, we highlight the research outputs from our researchers in 2015. In addition to this, the most excellent researcher in publications from 2012 till today is also promoted here. It is hoped that this corner could give a fruitful insight and motivate other researchers in UTeM and other universities to enhance their research and innovation undertakings.

On behalf of the editorial board, I would also like to thank all researchers and UTeM's staff members who have contributed to the success of this edition. A special thanks also to all readers who spare their time to read and support this RICE bulletin.

EDITORIAL BOARD

Patron
Prof. Ir. Dr. Mohd Jailani Mohd Nor

Advisor
Prof. Dr. Ahmad Zaki A. Bakar
Assoc. Prof. Dr. Badrul Hisham Ahmad

Chief Editor
Dr. Massila Kamalrudin

Members
Dr. Umar Al-Amani Haji Azlan, Assoc. Prof. Dr. Azmi Awang Md Isa, Assoc. Prof. Ir. Dr. Rosli Omar, Dr. Abd Rahman Dullah, Assoc. Prof. Engr. Dr. Hambali Arep @ Ariff, Assoc. Prof. Dr. Burhanuddin Mohd Aboobaidar, Dr. Chew Boon Cheong, Assoc. Prof. Dr. Zahriladha Zakaria, Dr. Hidayat Zainuddin, Dr. Mohd Fadzli Abdollah, Dr. Haslinda Musa, Dr. Zaleha Mustafa, Mohd Nizam Mazlan, Prof. Dr. Rabbiah Ahmad, Ruziah Ali, Dr. Zulisman Maksom, Dr. Zul Azri Muhammad Noh, Dr. Safiah Sidek, Dr. Rahman Hashim, Syahira Mohd Adnan, Rasida Abu Bakar, Aida Salleh, Rahizah Abdul Rahman, Assoc. Prof. Dr. Sivarao A/L Subramonian, Dr. Shajahan Maidin.

Printed and Published in Malaysia
Penerbit Universiti
Universiti Teknikal Malaysia Melaka
Kampus Bandar, Aras 1, Blok B, Jalan Hang Tuah,
75300, Melaka.

OUTSTANDING RESEARCH PERSONNEL

ASSOCIATE PROFESSOR DR ZAHRILADHA BIN ZAKARIA

Q: Can you tell us about your family background and a little information about your work experience as well as educational qualifications?

A: I was born on December 16, 1975 in Rengit, Batu Pahat, Johor. I am the third of four siblings. My early education began at Sekolah Kebangsaan Rengit, Batu Pahat and Sekolah Menengah Benut, Batu Pahat. After completing my secondary education, I then pursued my B. Eng. and M. Eng. in Electrical and Electronic Engineering from the Universiti Teknologi Malaysia in 1998 and 2004 respectively. I obtained my Doctorate from the University of Leeds in September 2010 in the field of Microwave Engineering. My career began in 1998, when I worked as a Product & Test Engineer with a semiconductor company, that is STMicroelectronics, an Italian and French –based company in Muar, Johor from 1998 to 2002. After working for four years in the industry, I joined the Universiti Teknikal Malaysia Melaka (UTeM) (formerly known as Kolej Universiti Teknikal Malaysia Melaka (KUTKM)) in April 2002 as a tutor. I am married and blessed with four children.

Q: What are your research interests?

A: My current research interests are in the areas of RF/Microwaves, Antenna and Wireless Communication System. The major focus of my work has been the theoretical and computational analysis in designing microwave devices and components such as filters,

couplers, antennas, amplifiers, rectifiers, etc for variety of applications including RF front-end subsystems, RF energy harvesting, microwave sensor, security and microwave imaging for medical. In addition, the other focus of my work is the investigation of wireless communications performance through the enhancement of TCP/IP protocol, characterization of optical communication and 3D image processing for industrial applications. Much of the above work makes use of our faculty's extensive state-of-the-art equipment's and facilities.

Q: What has been the highest point of your career so far?

A: I have published more than 100 scientific papers in journals, proceedings and book-chapters. Together with my research team, I have secured more than 25 internal and external research grants with a total amount of approximately RM 2 million and hold 5 intellectual property rights. I have supervised / co-supervised 6 PhD and 15 MSc students. I have won several awards including gold medal during several research and innovation exhibitions at the national and international level, such as the UTeMEX 2012, 2013 & 2015, Malaysia Technology Expo (MTE 2012-2014), International Trade Fair Ideas Inventions New Products (iENA 2012) in Nuremberg, Germany, Seoul International Invention Fair (SiIF 2013) in Seoul, Korea. I was awarded with the "Anugerah Perkhidmatan Cemerlang 2013 & 2014" and "Anugerah Penulisan Makalah Jurnal 2014". I am also a member of the Institute of Electrical and Electronics Engineers (IEEE), Institute of Engineers Malaysia (IEM) and Board of Engineers Malaysia (BEM).

Q: What are the challenges to be a good researcher?

A: As an academician, securing research grants and obtaining good research students are crucial for the progress of our research activities. Especially in the current situation of limited resources, it becomes more competitive to secure research grants. Thus, we need to find partners (within the university, other universities and industries) to collaborate and complement with each other.

Q: Finally, what is your advice to the young researchers in UTeM?

A: We are not perfect. But, we must try our best in whatever we do. This statement is consistent with the Arabic word 'Itqan' that indicates quality work. The combination of work smart, work hard and work fast is important for us to significantly progress in our research works. Thus, we need to strategically and tactically plan and implement our research activities. Mahatma Gandhi once said, 'The future depends on what you do today'.



Total Approach in R & D Management

Alhamdulillah, we have managed to improve our performance in securing research grants! There is no doubt that researchers feel excited and enthusiastic when their research proposal is accepted together with a certain amount of budget to carry out the research project. However, we cannot be complacent with the achievements. There is another challenge faced by researchers who have secured the research grants. They have to deliver what they promise in their research proposal. In other words, they need to make sure that they manage the research project effectively and spend the grant money wisely. However, we have heard many complaints that researchers could not manage their research project effectively! It has become a concern that the millions of RM research grants received ended up with unspent balances at the end of the project tenure and there are instances of incomplete research projects!

Thus, the wild idea of this issue is to highlight the need to adopt a total approach in R&D management. Researchers need to have the competency to secure research grant as well as to manage their research project effectively. There is no doubt our researchers have gained the skills and knowledge of securing a research grant, resulting from their continuous participations in workshops such as coaching in preparing winning research grant proposal and exposing researchers to the available grants from various sources- a complete campaign. However, we tend to take for granted that researchers are able to manage their research project on their own: Researcher should have the required skills such as delivering the research output on time, working effectively with team researchers and spending the research grant wisely and effectively. From my perspective, this issue shouldn't occur as each of the project leader has detailed out in their proposal of the project milestone. We assume that they will follow

through. Again, our assumption is wrong. This is the missing link in the process of practicing an effective management of a research and development project. I am certain, we will face with another hiccup or challenge in the future if this matter is not taken up.

In this case, it is crucial for researchers to have a wider perspective when conducting a research project. They should have a holistic knowledge and skills to manage a research project, which encompasses i) preparing a winning proposal and producing research output on time, ii) working effectively with team members, iii) spending the research grant effectively, iv) writing prudent progress report, and v) preparing to commercialise the research product. A researcher who has all these five skills is considered as a competent researcher as he/she is able to perform the Total Approach R&D Management. In addition, researchers should also be aware that they are accountable to the trust given by the public to deliver R&D product that projects good ROI. Having this awareness, I think they will spend the grant money wisely.

It is in my opinion that we need to have a total R & D project management approach. The module should consist all the crucial elements of good project governance such as smart expenditure, milestone, report writing, team role, publications, Intellectual Property Rights, lab and equipment management and others. In this case, CRIM and the technology transfer office have to take the challenge in educating and developing our researchers. The researcher must be groomed to acquire all these traits prior to the research journey and conduct research for a grand purpose.



R&D PERFORMANCE OF 2015

In 2015, UTeM's researchers have secured 106 national research grants worth RM 8,102,422.75 and 72 internal grants worth RM921,916.40. Considering that Malaysia is facing an economic crisis, this is a good achievement. With the continuous support and cooperation from researchers, UTeM have successfully secured national as well as industrial grants from MARA, KTP, PPRN, Science Fund and many more. This performance also shows that our researchers have strengthened their knowledge and skills in writing a winning proposal as they manage to secure national grants by producing good quality proposals. The trend is changing now as they no longer solely depend on securing internal grants to do research. They are aware that there are many external opportunities to apply for research grants. Figure 1 shows the distributed research grants secured from different agencies and ministries.

2015 Grants Secured

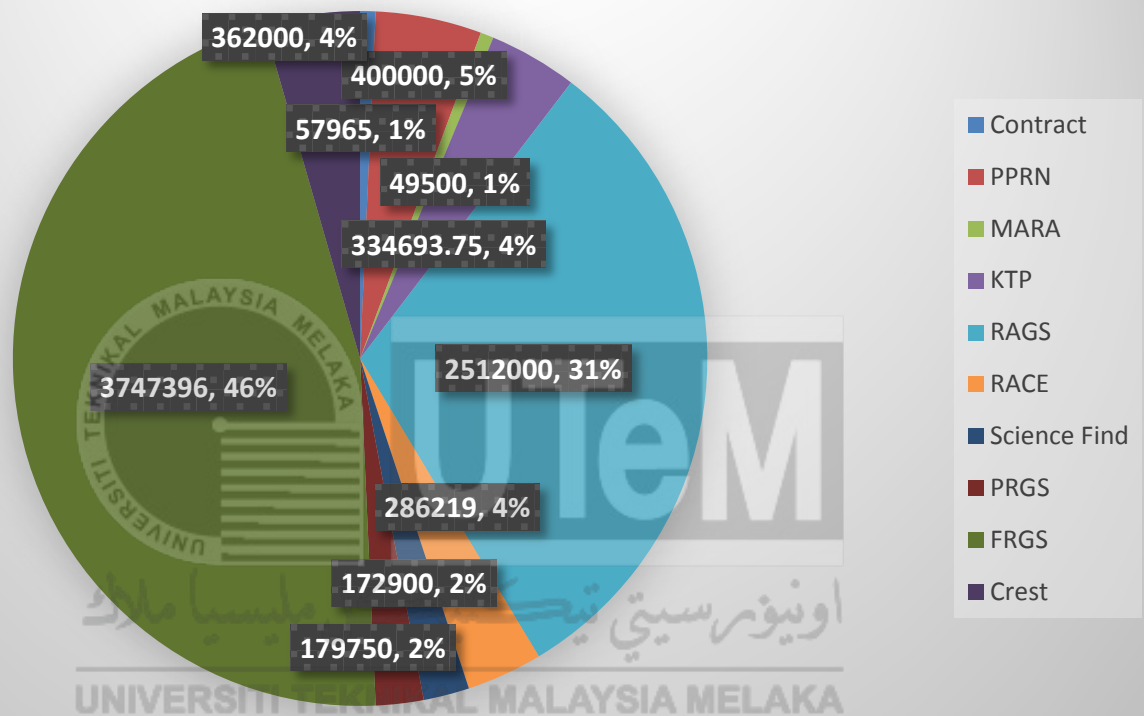

Figure 1: Distributed research grants secured from different agencies and ministries.

As one of the four technical universities in Malaysia, UTeM's research was supported by 6 CoEs namely:

- AMC-Advanced Manufacturing Centre
- CARE-Centre for Advanced Research on Energy
- CeRIA-Centre for Robotics and Industrial Automation
- C-ACT- Centre for Advanced Computing Technology
- CETRI-Centre of Electronics & Telecommunication Research Institute
- C-TeD-Centre of Technopreneurship Development

With respect to the output of research particularly in the area of publication, researchers from UTeM have successfully published 10 ISI indexed and 263 Scopus indexed Journals in 2015. As for conferences UTeM have published in 105 ISI indexed and 80 Scopus indexed Conferences. These results are shown in Figure 2. 13 of UTeM's academic staff have H-index more than 10 and 111 staff have H-index of more than 5 in 2015. A total of 573 staff have registered with Google Scholar. Table 1 shows the H-index of UTeM's staff.

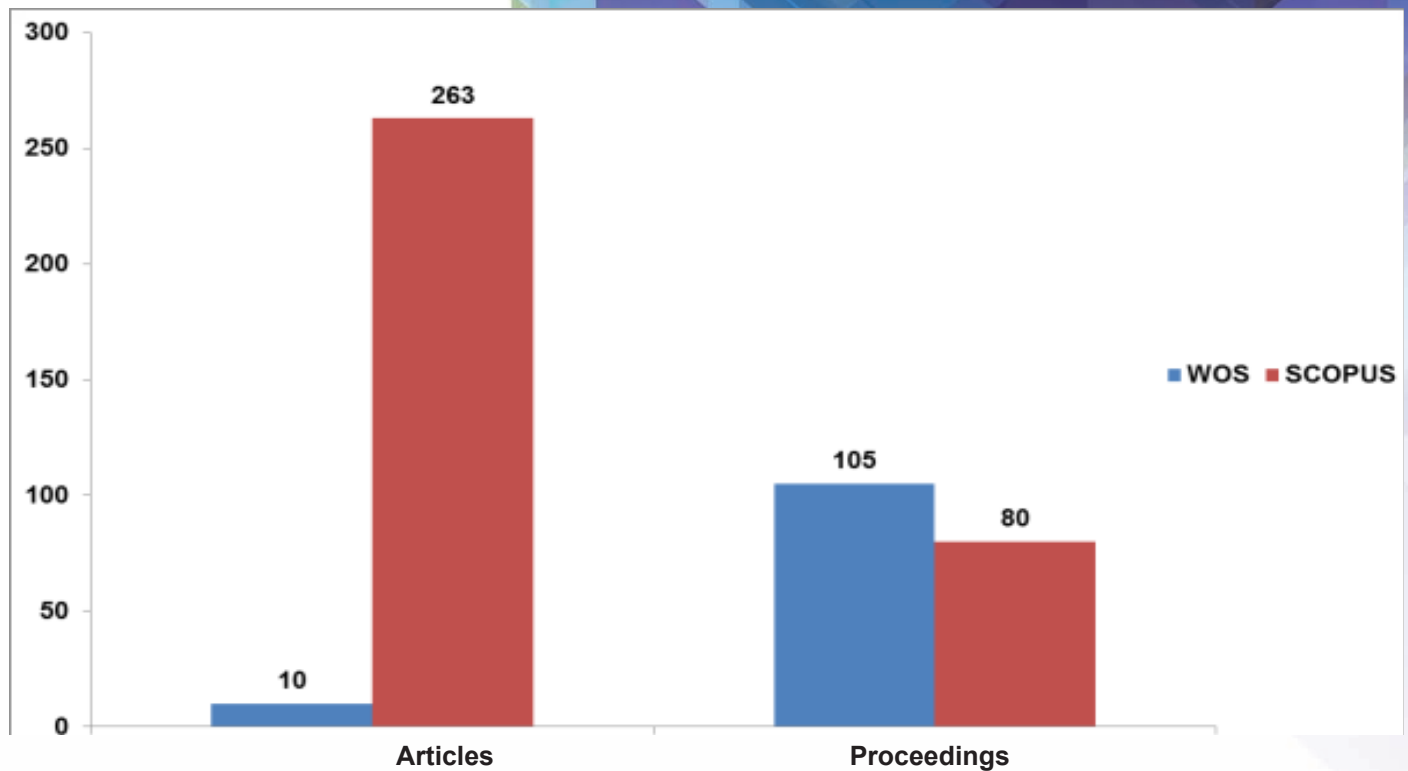

Figure 2: UTeM's 2015 publication

	H Index ≥ 10	H Index ≥ 5	H Index ≥ 3	H Index ≥ 1	H Index = Null	Total
Professor	4	13	3	3	0	23
Associate Professor	3	22	8	4	1	38
Senior Lecturer	6	56	95	91	7	255
Lecturer	0	20	64	123	38	245
Senior Teaching Engineer	0	0	0	5	0	5
Teaching Engineer	0	0	2	4	0	6
Language Teacher	0	0	0	0	1	1
RA/GRA	0	7	9	61	31	108
PhD Student	1	4	4	6	6	21
Total	14	122	185	297	84	702

As a conclusion, UTeM has shown a significant increase, especially in research and publication in 2015. In the years to come, it is expected that the research and development in UTeM will grow and UTeM will become a reference center in the area of Sustainable Manufacturing Technology. It is hoped that UTeM will achieve a 5-star ranking in MYRA.

ACHIEVEMENTS/ EVENTS



Photo 1: Group photo with the participants

Inaugural SEDA GCPV Wireman and Chargeman Certified Course at UTeM

Following the appointment by SEDA as an authorised training center, UTeM has conducted its inaugural SEDA Grid-Connected Photovoltaic Systems (GCPV) Course for Wireman and Chargeman from 11 to 15 November 2015 at the Research Laboratory of Solar PV Systems and Smart Grid, Faculty of Electrical Engineering. The training course has received an overwhelming response: A full-house registration consisting of 20 participants from government agencies and industries have joined this inaugural course.

At the end of the five-day course, the participants were given trainings on both the theory and practical aspects of GCPV systems prior to the respective examinations. The training sessions on the theory introduces the underlying principles of GCPV systems from the perspectives of wireman and chargeman. Meanwhile, the practical session comprises three sub-modules, namely, the Testing and Commissioning (T&C) procedure, PV module characterization and shading analysis. Overall, this inaugural course was a great success.

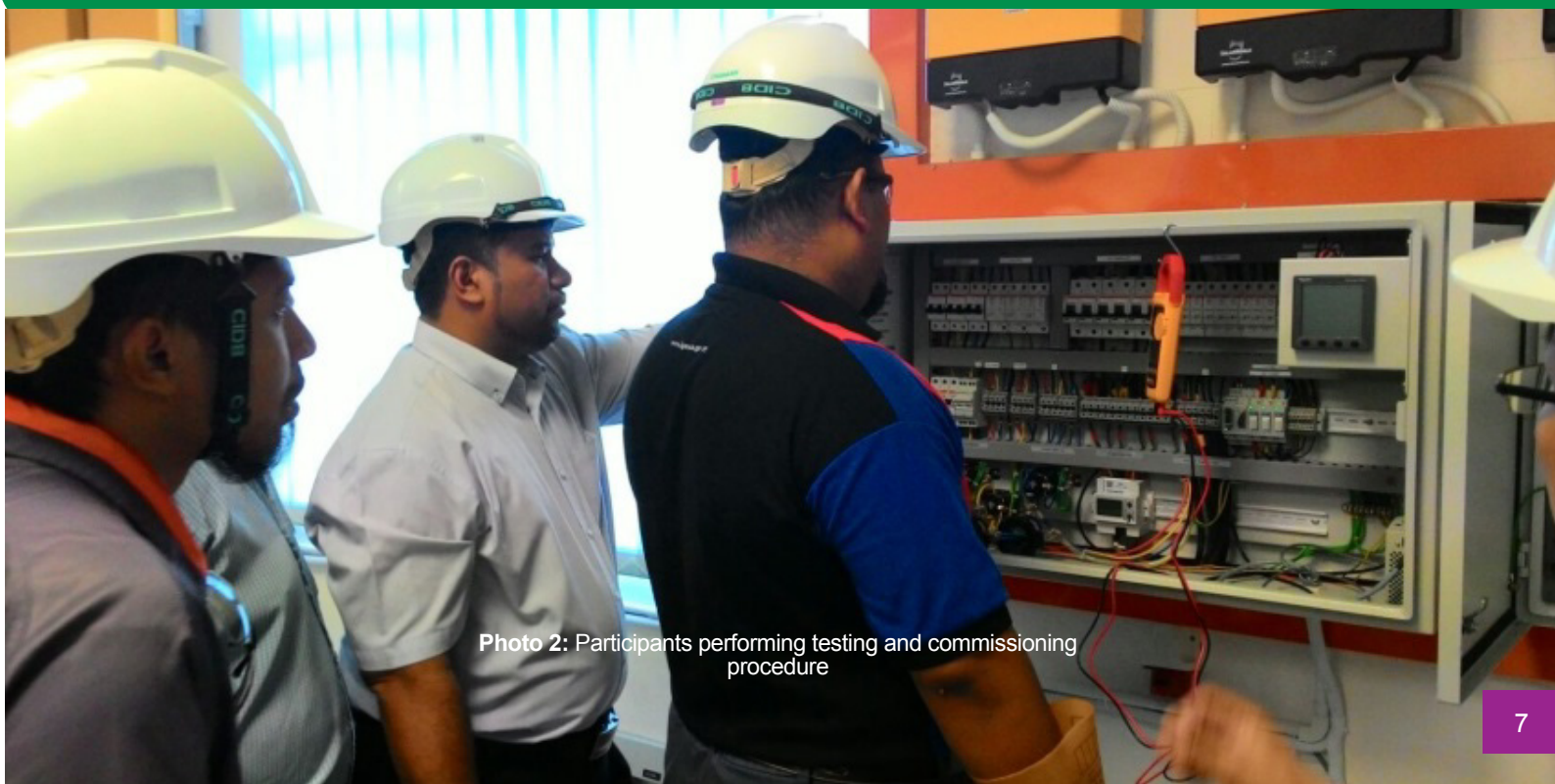

Photo 2: Participants performing testing and commissioning procedure

Showcase of

KUALA LUMPUR ENGINEERING SCIENCE FAIR 2015

Mohamad Haniff bin Harun
Faculty of Engineering Technology (FTK)

The Kuala Lumpur Engineering Science Fair (KLESF) is an initiative consisting of various programmes and activities that aim to promote interest in science, technology, engineering and mathematics (STEM) among primary and secondary school students. The KLESF partners comprise the ASEAN Academy of Engineering and Technology (AAET), Universiti Tunku Abdul Rahman (UTAR), Malaysian Industry-Government Group for High Technology (MIGHT), and Institution of Engineers Malaysia (IEM). The KLESF programmes also support the "Science to Action (S2A)" initiative launched by Prime Minister on the 1st November 2013. This event was conducted from the 30th October 2015 until 1st November 2015 at the MINES International Exhibition and Convention Centre (MIECC) Jalan Dulang, MINES Resort City, Seri Kembangan, Selangor. The conduct of this fair is based on four main objectives:

- To enhance the interest in science, technology, engineering and mathematics (STEM) among school students
- To enhance the awareness of public on the roles and importance of STEM in socio-economic well-being and sustainable development
- To enhance the awareness and participation of business and industry in promoting learning and career development in areas related to STEM among school students and community
- To provide networking for schools, educators, industries, public and private sector to share information and experiences on projects, extra-curriculum and good practices in science and mathematics education in schools

Led by the Faculty of Engineering Technology (FTK), UTeM is one of the universities that collaborates with selected industries and institutions for the success of the 2015 KLESF. The role of the FTK is to showcase two concepts of Roborobo, namely the development and the use of robot. This exhibition was led by Mohamad Haniff bin Harun and assisted by Mohd Zaidi bin Mohd Tumari, Khalil Azha bin Mohd Annuar, Ab. Wafi bin Ab Aziz, Muzaffar bin Abdul Kadir, Muhammad Falihan bin Bahari and Muhammad Syahrani bin Johal. FTK students were also involved in the running of the fair.



A Research Visit To IBM Triangle Park, USA

In an effort to strengthen the MOU between IBM and UTeM, two members of IS3 research group, namely Dr Massila Kamalrudin and Dr. Safiah Sidek have visited the IBM laboratory at Triangle Park, USA on the 1st of September, 2015. The main objective of the research visit was to build relationship, collaboration and sharing of ideas in the field of software testing methodology. This includes the sharing of real world examples implementation of software automation and container technologies such as Component Based Automation and Docker.

The agenda of the one-day research visit comprises of four presentations by IBM representatives and one presentation from the IS3 research team. The presentations from IBM were about CBA Automation and Demo, presented by Mr Amal Kalso, the lead Automation Engineer for Netcool, Internet of Things by Sky Mathers, the Chief Technical Officer for IoT, Watson by Sridhar Iyengar, the IBM Distinguished Engineer, Cognitive Applications and Solutions Research, Cloud Unit Software by Janine Gerger, Cloud Academic Initiative Leader. Meanwhile, the IS3 research team shared their innovative tool called TestMeREQ. Further, discussions for possible research collaborations between the two parties were carried out. The IS3 research team has also managed to get constructive feedbacks from the IBM experts on the possible improvements for the TestMeREQ and the possibility of integrating TestMeREQ with Watson, the human

intelligent robot. For further collaboration, discussions for a research visit to Watson Lab at New York has been initiated as well. The research visit was fruitful and further research collaboration between two parties have been extended and possibility of student internship at IBM has also been promised.





UTeMEX 2015

A grand event of UTeM Research and Innovation Expo 2015 (UTeMEX 2015) has been successfully organized by UTeM Commercialization Centre (UCC) on the 27th & 28th of October 2015 at the Dewan Besar UTeM. This is the third time of such an annual grand innovation event has been organised in UTeM. The expo received 202 entries from inventors from local Universities, Research Institutes, Polytechniques, Community Colleges. This competition is considered as

a catalyst to stimulate research and innovation among the community in addition to contributing to strengthen the discourse of quality and competitiveness to establish solutions with high commercial values for researchers. The competitors were categorised into five focus areas, namely the i) Green Technology, ii) Emerging Technology, iii) Systems Engineering, iii) Human-Technology Interaction and Open. In addition, various relevant activities opened to all participants were also held in parallel, such as the business plan development, innovation pitching, intellectual property rights. Special innovation competition called Theory of Inventive Problem Solving (TRIZ) was also conducted for primary and secondary students involving 30 entries. The prize-giving and closing ceremony has been successfully officiated by YBrs. Datuk Dr. Zulkifli bin Mohamed Hashim, Deputy Secretary General (Science), Ministry of Science, Technology and Innovation.



24th Scientific Conference of Microscopy Society Malaysia (SCMSM2015)

Dr. Zaleha Mustafa
AMC/FKP



The Faculty of Manufacturing and the Centre for Advance Manufacturing in collaboration with the Microscopy Society Malaysia have proudly organized the 24th Scientific Conference of Microscopy Society Malaysia (SCMSM2015) on the 2nd – 4th December 2015 at the historical city of Malacca. This conference is an annual event and this year it embraces the theme of Minute to Massive: Harnessing Microscopy for Sustainable Manufacturing and Innovative Life Science. The conference was successfully officiated by the Deputy Minister of Science, Technology and Innovation Y.Bhg. Datuk Dr. Abu Bakar bin Mohamad Diah. This conference has proven to be a successful platform for researchers, academicians and industrial practitioners to share the current advances and innovations in both life and physical sciences in this ultra-fast revolving scientific world. It received more than 68 scientific and technical papers presented by participants. In addition, the latest development in microscopic image analysis technology to support the various manufacturing technology such as Nanotechnology and Green technology was also shared during the conference. Full length of selected papers of SCMSM2015 will be published in Scopus indexed Key Engineering Materials and Malaysia Journal of Microscopy.

SERIES OF TMAC 2015

1st TMAC SYMPOSIUM 2015

2nd - 3rd March 2015

Universiti Teknikal Malaysia Melaka



On the 22nd September 2014, University Teknikal Malaysia Melaka (UTeM) and University of Tokushima (UT) have signed a Memorandum of Understanding (MoU) which led to the establishment of UTokushima-UTeM Academic Centre (TMAC). The aim of TMAC is to strengthen international relations and the existing academic relations between UTeM and UT. Apart from that, TMAC is expected to be a catalyst for academic and advanced research collaboration that is beneficial to the staff and students of UTeM and UT. Among the programs held through this collaboration is the 1st and 2nd TMAC Symposium. The first TMAC Symposium was held on 2nd and 3rd March 2015 in UTeM, Malaysia.

Objectives

The purpose of these symposiums is to provide a platform for researchers of UTeM and UT to recognize their potential for collaborative relationships, expand their research activities at the international level and thus identify opportunities for cooperation in the future.

Participants

Key note speakers:

1. Professor Ir. Dr. Mohd. Jailani Bin Mohd. Nor (Malaysia)
2. Professor Dr. Akutagawa M. (Japan)
3. Professor Dr. Horikawa T. (Japan)
4. Professor Dr. Nakagaito A. (Japan)
5. Professor Dr. Uto Y. (Japan)
6. Professor Dr. Yoshida M. (Japan)
7. Professor Dr. Tsukagoshi M. (Japan)
8. Professor Dr. Yamashita S. (Japan)
9. Professor Dr. Haraguchi M. (Japan)
10. Professor Dato' Dr. Abu Bin Abdullah (Malaysia)
11. Professor Dr. Marizan Bin Sulaiman (Malaysia)
12. Assoc. Professor Dr. Zahriladha Bin Zakaria (Malaysia)
13. Professor Dr. Ahmad Zaki Bin A Bakar (Malaysia)
14. Professor Dr. Md Radzai Bin Said (Malaysia)



اونيورسيتي تيكنيكل مليسيا ملاك

2nd TMAC SYMPOSIUM 2015

8th September 2015

The University of Tokushima, Japan

- **Objectives:** The purpose of these symposiums is to provide a platform for researchers of UTeM and UT to recognize their potential for collaborative relationships, expand their research activities at the international level and thus identify opportunities for cooperation in the future.

The 2nd TMAC Symposium was held on the 8th September 2015 in Tokushima University, Japan. This symposium was organized with the conjunction of Tokushima University Engineering Festival 2015 and was participated from both universities which were 9 participants from UTeM and 8 participants from Tokushima University. Gratefully, Tokushima University has supported travel expenses covering the return ticket fees and one night accommodation for UTeM participants.

- **List of participants from Malaysia**

1. Dr. Mohd Amran Md Ali - *Effect of CNC Milling and EDM Die Sinking Process on Surface Roughness of Core Mould Surface*
2. Dr. Mohd Hadzley Abu Bakar - *Investigation of Tool Wear Characteristics when Machining FC 300 Gray cast iron with Uncoated Carbide End Mill*
3. Dr. Mohd Sanusi Abdul Aziz - *Characteristic and Cutting Performance of Alumina-based Cutting Tools Fabricated Using Cold Isostatic Press*
4. Prof. Dr. Qumrul Ahsan - *Analysis of sound absorption properties of spent tea leaf*
5. Mr. Hassan Attan - *Feasible Study on Dental Restoration Using Time Compression Technologies*
6. Dr. Wan Hasrulnizam Wan Mahmood - *Exploratory of Cleaner Production Performance Factors – Response from Malaysian Manufacturers*
7. Assoc PM Dr. Noreffendy Tamaldin - *Cylinder Deactivation Impact on Engine Performance and Emission for SI Engine*
8. Mr. Souffwee Rahman - *Applying Poka Yoke Jig in PFMEA to control zero defects and reducing RPN via detection*
9. Mr. Syahrul Azwan Sundi - *Comparison Study on the Effect of Surface Finish Programmed by CATIA V5 and DELCAM CAD/CAM Software Using Scanned Data - Reverse Engineering*

In this symposium, poster presentation session was conducted by participants and there were a lot of discussions among researchers from both universities to collaborate together in the future. Based on the evaluation of the symposium committees, Dr Mohd Sanusi Abdul Aziz of UTeM was awarded as the best presenter for the poster presentation.

Gallery Pictures

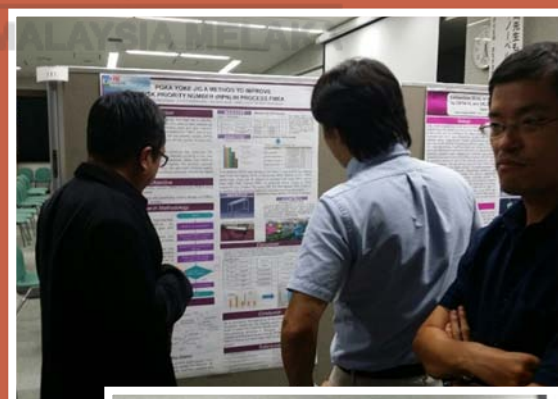
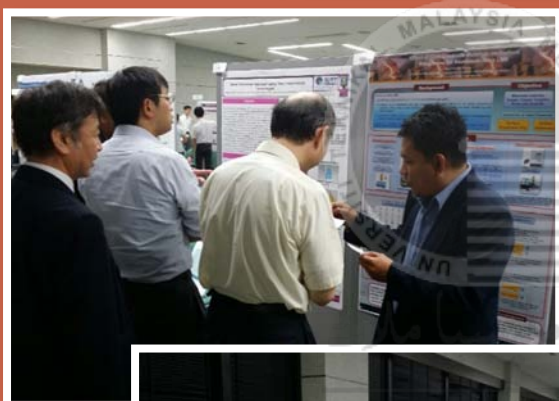

1st Design Workshop 2015

2nd -7th March 2015
Universiti Teknikal Malaysia Melaka,
Malaysia

The first Design Workshop 2015 was held on the 2nd until 7th March 2015 in UTeM, Malaysia.

Objectives

TMAC Workshop Design 2015 saw the participation of students from Faculty of Manufacturing UTeM and UT in generating ideas to solve a problem. For this programme, the UT has presented 10 Lego units consisting of 5 basic units containing 5 controllers and expansion units with a total cost of RM 20,000.00.



Commercialisation

Research Highlights

Product Title:
Mobile Robot Feedback Control And Monitoring System

In-memory database:
Dealing with velocity problem of big data

Principal researcher :
 Ir. Dr. Tan Chee Fai



The Mobile Robot Feedback Control and Monitoring System provides a mobile robot system in which an operator may check the status of the mobile robot conditions and the environment of the mobile robot location by using sensors and video camera. The Mobile Robot Feedback Control and Monitoring System are used for controlling the robots such as high density light, water cannon module and motor encoders. A wireless module is connected to the Mobile Robot Feedback Control and Monitoring System for transmitting and receiving data used for monitoring and controlling the mobile robot. The robot system further comprises an information wireless network connected to the robot controller for transmitting and receiving information between the robot controllers. The robot controller has the function for checking the status of the mobile robot, controlling the mobile robot, monitoring the environment where the mobile robot is located, and controlling the different modules that will be installed on it. The Mobile Robot Feedback Control and Monitoring System is a state-of-the-art technology for the mobile robot system.

By: Dr. Nurul Akmar Emran,
 (Database Unit, CIT Lab,
 C-ACT)



In-memory database (IMDB) technology is not new. We can find the earliest version of a commercialised in-memory database called as the TPF (Transaction Processing Facility) by IBM as early as 1979. Research on in-memory computing must have been around years before the launching of TPF. We know that this research area is still alive as the number of IMDB proposed keeps increasing every year. Today, about at least fifty variants of IMDB can be seen on the shelves (or as freeware). The latest (in 2015) is Apache Geode which is developed by Apache Software Foundation as an Open source (Apache License). Among other popular developers of IMDB are Oracle (TimesTen, Oracle 12c), SAP (SAP HANA), Aerospike Company (Aerospike), IBM DB2 (BLU Acceleration), Pivotal Software (GemFire), VoltDB Inc. (VoltDB) and SQLite (SQLite).

The aim of in-memory computing is to move data as close as possible to processors. This is enabled by storing data directly on the server's RAM. An IMDB is the manifestation in-memory computing technology that represents a database management system that relies heavily on main memory for data storage, management and manipulation. Unlike traditional database management systems that employ a disk storage mechanism, IMDBs are faster as fewer CPU instructions are executed with simpler internal optimization algorithms. Figure 1 shows an example of a comparison between a disk based RDBMS and an Oracle's IMDB called as the TimesTen in terms of query processing.

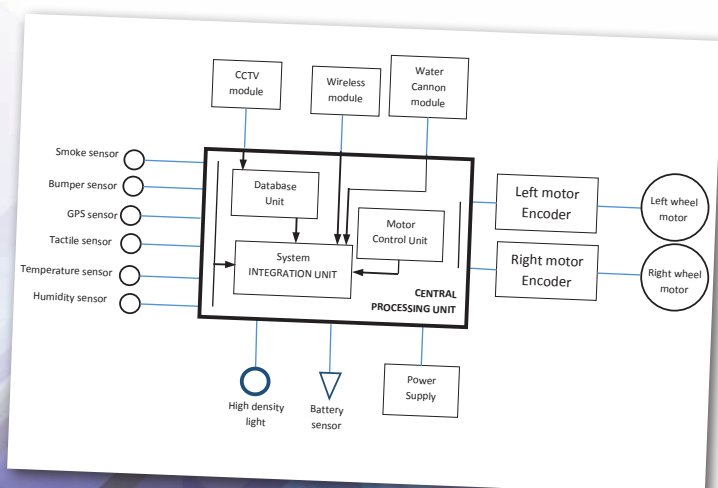

Lean And Database Management

By: Ir. Assoc. Prof. Dr. Puvanasvaran A/L A.Perumal
 Research Group: Lean Integrated System and Standardization (LISS)

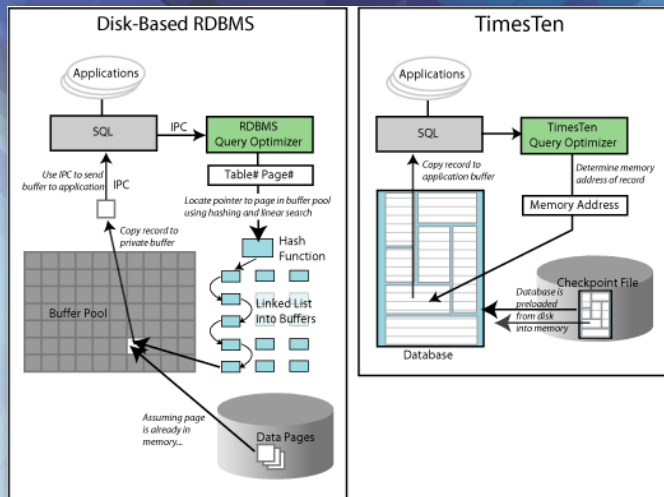
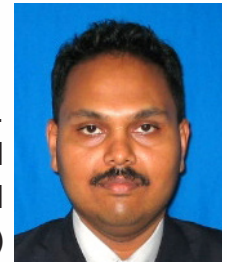

Figure 1: A comparison of disk-based RDBMS to TimesTen in-memory database [Source: Oracle Help Center, TimesTen Application-Tier Database Documentation, 11g Release 2 (11.2), 2015]

As the arsenal of IMDB is its speed, time-critical applications such as Big Data often benefit from IMDB. According to Aberdeen's report1, almost all Big Data problems are about time. "Velocity", (besides "Volume" and "Variety") which is known as a Big Data problem requires Big Data practitioners to cope with the speed of information processing and delivery issue. Traditional analytics and data management software unfortunately require more time to process data into understandable and actionable information as greater volumes of data streams into the database. This is where IMDB can fit to address the big data challenge. It has been reported that, IMDB excels in processing large amounts of structured data very quickly and outperforms their peers. In addition, IMDBs are able to analyze over three times the amount of data at over a hundred times the speed of several organizations. Nevertheless, IMDB's potential in dealing with semi-structured and unstructured data has not been tested. This is a limitation of IMDBs that opens for further research that will contribute to not only Big Data community, but also to a wider audience of data management practitioners.

Managing waste elimination database in lean manufacturing was my early exploration of integration. This integration introduces an application for managing the waste elimination database in lean manufacturing to improve the visual indicators and enhance the problem solving capabilities of the employees in the organisation as the basic success factors to drive the process of continuous improvement culture forward. Ineffective database systems within the organization have caused inaccurate, redundancy and inconsistency of data. Lean implementations are not successful because there is a lack of communication and involvement of all levels of employees.

By adopting the lean and data base management, the employee can easily keep track on the improvement projects and the management can monitor the improvement task and problem solving capabilities of the employees. The visual indicators are improved because meaningful charts and reports are generated for visual and filling purposes (Figure 1 & 2). Besides, implementing the problem solving cycle in the designed application to improve the problem solving activities is also an important element in creating continuous improvement culture.

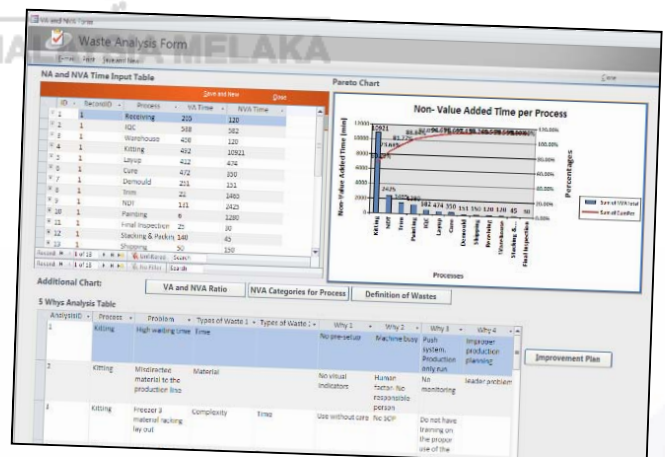

Figure 1: Waste (value added and non-value added) analysis form

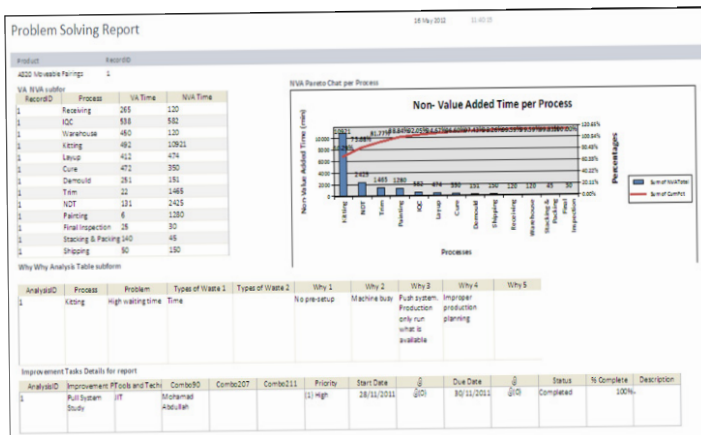

Figure 2: Problem solving report.

Application Of Defect Detection In Gluing Line Using Shape-Based Matching Approach

By: Mohamad Haniff bin Harun
Faculty of Engineering Technology



Vision-based inspection of industrial products offers low-cost, high-speed, and high-quality detection of defects. One of the most challenging industrial inspection problems is dealing with the textured of the gluing process. Defects often happen during gluing process. To ensure that only quality units are produced, defects detection and recognition system are commonly installed to segregation the defects unit. There are many techniques that provide a solution in recognizing an image or object in image processing such as region, edge-based features, feature extraction, shape context, Gaussian Curve and etc. Other researches were based on HALCON Application for Shape-Based Matching. The researches discussed about the process involved in basic shape based matching algorithm together with Extended Region of Interest (ROI) function available in HALCON that fulfils shape based matching to find object based on a single model image with sub pixel accuracy. The basic concept of defect matching using shape-based matching algorithm is based on Extended Region of Interest.

is classified as the recognition rate. Higher recognition rate means the systems proposed are effective and optimized. This application is easier to process because it reduces the region known as the Region of Interest chosen by the users. Processing time can also be reduced apart from producing higher recognition rate. The potential of the proposed visual algorithm system was the flexibility of the program to accommodate changes. 10 images are being tested repeatedly for 10 times for its flexibility in determining all defects occur in the tested images. The tested images are filled with all the three defects models that are already being trained in training phase and fed into the system for recognition purposes. Based on the results, the recognition rate of the experiment is about 95.14% based on 3 model defects created through the system. A comparison was conducted where it considered the problem in detecting welding defects in welding lines where the past researchers put an effort on more complex algorithm or limited in efficiency.

An improved filter method that uses a computer to automatically recognize the gluing defects is put forward. In this approach, firstly, the digital image of the gluing defects is binarized. Then, ROI is further processed. Correlation algorithm refines the image. Once the important feature of the binarized image has been extracted, the features are trained for defect classification. To better understand this method, each kind of defects is elaborated further. ROI is applied to reduce processing time. Then depending on the features classification of the defect, feature extraction and Gaussian smoothing are used. Figure below shows the proposed system.

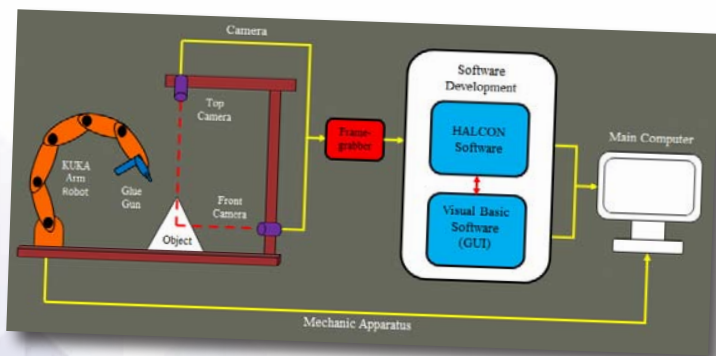

Shape-based matching application is divided into two phases: Training phase and Recognition phase. The training phase is important in identifying the defect correctly. If the usage of the specific data is not optimized, the result will not be as accurate as what we desire. Hence, defect matching that results in high accuracy and precision depends on the best reference image transformation. Matching phase is used to find similarity between the reference images and the tested images. Similarity

	Weld Defect Detection	Fabric Defect	Glue Defect
Number of Samples	500 samples	Not stated	236 samples
Variation of Samples	6 types	>30 types	3 types
Recognition Rate (%)	94.3%	92%	95.14%
Error Rate (%)	5.7%	5%	4.86%

The table above shows the comparison between the glue defect detection with both the weld and fabric defect detection. The comparison is based on the method being used in introducing training and recognition phase. Each of the defect detection recognition rates are evaluated using pattern recognition which compares pixels by pixels between model template trains through training phase with the object tested capture from recognition phase. Pixels matching between both models known as Score will be calculated for this research.

Energy Saving Device: A Fairytale

By: Mohd Firdaus Mohd Ab Halim
Faculty of Engineering Technology



The economy of our nation is not in a good shape at the moment. Even though the commodity price such as oil dives, it does not necessarily influence the consumer products in the same way. The same goes to the utility bills like electricity where the tariff remains the same or could go higher. Most of the citizen in this country are beginning to carefully adjust their spending accordingly and smartly. Any opportunity to reduce their expenses is good news. Recently, the energy saving device has been one of the popular products among people who wanted to save their spending in utility bills. The product seller claimed that this device can reduce their electricity bills by more than 30%. If your monthly electricity bill is more than RM 200, you could save RM 60 per month. This device is sold in the range of RM 80 to RM 300. By simple calculation, the buyers would break even in 3-5 months.

Does this product really work? Unfortunately the product reliability has been debunked more than 20 years ago in the United States. At that time, the products look different but the internal parts are similar and the same pitching statement and demonstration is used to attract the buyers. Let's take one example of how the seller approaches its customer. First, the seller will ask your average monthly bill. Then, the rest of the conversation will focus on the reduction of the bill and the return of investment. The seller would also show customer's testimony and monthly bills showing a nice downtrend. The seller also demonstrates the value of current reduce when the device is plugged in the electrical network. Most of the customers believe that this product is working as claimed because they are misinformed by the seller due to the lack of electrical engineering knowledge (which very normal).

Why does this device does not reduce the electricity bill? It is just because the electricity bill is charged in Kilowatt or real power and not Kilo VA or reactive power. During the demonstration, the seller shows that current is decreasing, implying a reduction the reactive power. What they should honestly show is the decrease of real power. Will they be able to show the decrease of real power? Some may argue that instantaneous real power is inaccurate, and customer do not have the time to wait for one hour to get the average real power. Guess what, kilowatt meter that reads the average of the real power has already been existing in the market. The meter is also cheaper than the current clamp meter which the seller used to measure the current.

What is the device made of? Shockingly, inside this device is a simple circuitry to power the led indicator light and a capacitor. In different version of the product, we may see varistor (usually used as spike suppressor). The circuit actually can smoothen the flowing of electricity nearer to it and minimize the spike but not the electricity bills. If the device is connected to the electrical network without any inductive load, then it would make load to become leading power factor hence creating the same situation as lagging power factor. Instead of saving the electricity bills, the customers are actually using more energy to power up the device. Is there other way to reduce the electricity bill? There are many ways to do this and one of them is to manage your usage wisely. If you have low efficiency appliance, depending on your budget you can replace this appliances with higher efficiency appliances. This saving tip may not be something that most household wanted to listen compares to the statement by the electricity saving device's seller but that is the reality. Even after this article is published, there will still be fraudulent energy saving device in the market and people will still support the product. Thus, reader should share this information and educate the crowd about it so that everyone is aware that the energy saving device is a mere fantasy.



Kansei Engineering Approach to Measure Response in

Human-robot Interaction (HRI)

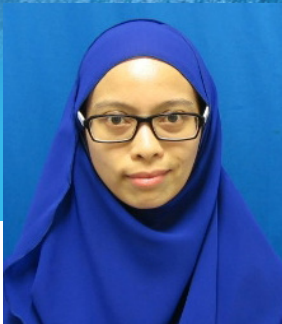

By: Syamimi Shamsuddin, PhD

Robots are fascinating and often considered as the epitome of current technology. Used to exist as factory automatons and as research 'articles' in solitary labs in universities, robots are now gaining places in our lives in a multitude of roles. The expanding role of robots coincides with the sole purpose of improving the lives of mankind. Effective usage of robotics technology as an educational tool holds promising and effective possibilities as it is motivating, accurate, objective and adaptive to the needs of teachers.

This study is about the application of a humanoid robot NAO which is designed for social interaction to engage with children in a fun and interactive way. The aim is to gain feedback on the specific features of NAO that are attractive to children in pre-school age. This study is one-of-a-kind in Malaysia as previous studies utilizing NAO for human-robot interaction (HRI) focuses on children with disabilities only.

The motivation for this research is the need to expose children in Malaysia to robotics technology. NAO is perfect for the role as it is cute, personalizable and interactive. The robot will bring new dimensions to how learning is conducted in kindergartens. Robots are definitely not meant to replace human teachers but it will be an instructive tool to help deliver learning contents in class.

To gather solid evidence on the use of robots for preschoolers, it is imperative to start with a pilot study on the emotional response of the children when meeting the robot for the first time. This is to ensure that the robot evokes positive emotional effect on the children. Only then will robot-aided learning will be effective. In the first experiment, the robot will be programmed to do simple interactive actions including sitting and standing, waving its hand in greeting, says 'Hello', dance to music and also asks simple questions to spark two-way conversations with the children.

Kansei Engineering (or emotional engineering) is a method to embed emotions in product designs. In this study, it finds out how the humanoid robot NAO triggers emotional reactions from the children. What are the children's feelings when exposed to the interactive robot? Which particular actions from the robot are most favorable to the children? These questions will be answered by observing the recorded videos of child-robot interaction.

The experiment will take place at a kindergarten. For the children to participate in this study, he/she needs to fulfill a set of inclusion criteria: he/she is a typically developing child, age between 4 to 6 years old, able to understand and respond to simple instructions in English and has parental consent. The interaction phase where children are exposed to HRI is the most important and critical stage in robot-based intervention. The environment, setting and involvement from individuals such as teachers, and even the experimenter herself needs to be taken into account. During the child-robot interaction, each child will be accompanied by his or her class teacher. The role of the teacher is not to give any instructions to the child but only to act as a 'comforting presence' as the pilot experiment exposes the humanoid robot NAO for the first time to the child. The robot will be in autonomous mode and the experimenter will not be visible to the child.

Since this is a qualitative type experiment which involves human behavior, analytical data will be obtained from the experiment through participant observation and interview method. The interview session with the children after the experiment will show which are the common emotions associated in child-robot interaction? It is expected that the children will show positive emotions such as 'happy' and show enthusiasm to imitate the robot's movements.

AWARD WINNING RESEARCH PRODUCTS

PROJECT TITLE

HEXI-CIENCY DRIVE

BLIND NAVIGATION WITH 1 SHIELD

A NOVEL MICROWAVE SENSOR WITH HIGH Q RESONATOR FOR HIGH SENSITIVITY MATERIAL CHARACTERISATION

PRINCIPAL RESEARCHER

DR AUZANI BIN JIDIN



KHAIRUN NISA BINTI KHAMIL



PROF MADYA DR ZAHIRILADHA ZAKARIA



PRODUCT DISCRPTION

This product is developed to facilitate the vector control of electric motor drive for obtaining high-efficiency and fast torque dynamic control. Unlike the conventional electric motor controller, the proposed method utilizes a hexagonal flux control strategy which is based on a look-up table and modification of torque error status. It can be shown that by utilizing the hexagonal flux control strategy, the most optimal voltage vectors are switched to reduce the switching frequency (to reduce the switching losses) and improve torque dynamic control. The significance of the product is that it offers superior torque dynamic control and high-efficiency which are mainly required for high power applications, e.g. electric vehicle.

As the technologies grow and develop, many types of wearable computers and assistive technology have been created for visually impaired people with varying amounts of cost. However, until today, the traditional white cane is still the number one choice among blind people, due to its low cost, as low as RM15 in Malaysia. This project is about a blind navigation system that sends information wirelessly from Arduino's shield to a Smartphone, in order to alert the user about the distance of obstacles through speech warning and vibration. Smartphone with haptic mode is chosen so that it can be easily detected by the blind. Four ultrasonic sensors are mounted on the cane to detect objects from all four directions, front, left, right and over waistline space. The ultrasonic sensor is chosen because it performs distance calculation which is not affected by ambient light with better detection range compared to the infrared sensor. Speech to alert the user will be written in Arduino coding as a distance notification. In addition, application of 1Shield that enables Arduino (the controller) to communicate with the smart phones can invoke other ability such as voice recognition which automatically sends message to the user's close relative when he/she is lost.

This invention presents a novel structure of planner microwave sensors for determining and detecting the dielectric properties in materials (solid/liquid). This sensor is suitable for various industry applications such as food industry/ halal-hub, control, medicine & pharmaceutical. It is believed that this technique would lead for a promising solution of characterizing material particularly in determining material properties and quality.

AGRO-WASTE FOR SUSTAINABLE SELF-LUBRICATING MATERIALS

DR MOHD FADZLI BIN ABDOLLAH



Agro-waste containing polymer composites have potential uses in siding bearings in a variety of applications. The purpose of this study is to investigate the friction coefficient and wear rate of kenaf powder/epoxy (KP/E) and oil palm empty fruit bunch fiber/epoxy (OPEFBF/E) composites. The KP/E and OPEFBF/E sample was fabricated by hot compression molding method. Tribological testing was conducted using a pin-on-disc machine according to ASTM G-99a. The findings provide insights that (KP/E) and OPEFBF/E can be useful as one of the most potential self-lubricating materials for bearing applications.

ADVANCED PROTOTYPE OF GRAPHENE SUPERCAPACITOR

DR MOHD ASYADI' AZAM BIN MOHD ABID



With the increasing environmental pollutions caused by fossil fuel consumption, there is a high demand to seek clean energy sources to ensure the sustainable development of society and economy. Alternatively, energy storage devices such as batteries, fuel cells, and supercapacitors have excellent capability to store electrical charge for various applications including portable devices, hybrid electric vehicles, emergency generators and etc. In particular, supercapacitors have become very attractive due to its charge storage ability to overcome or to have very similar performance with lithium batteries. Here, we present our prototype by utilizing grapheme as electrode material from a facile fabrication process.

E-TICKETING SYSTEM USING QR TECHNOLOGY

NURIDAWATI BINTI MUSTAFA



E-Ticketing System using QR (Quick Response) Code technology is a mobile application where customers can buy tickets via mobile. Every ticket purchased will be given a QR code for verification process. The QR code is essential during the boarding process where customers need to show their QR code before they go on board the bus. Bus driver will then scan customer's QR code to update the availability of the passenger. This will ease the management to check the overall passenger for every trip who have already boarded and have not boarded the bus. The current implementation needs staff to print the ticket during purchasing process at counter. Perhaps, customer needs to queue up in order to purchase a ticket. This new system will support the eco green campaign that has been urged by the government with using less paper. It will improve the current system by using QR code whereby it is more efficient for customers to keep the ticket. It also improves the management process in generating reports easily and systematically. Finally, this system will ease the customer to book their ticket via online using mobile application or web-based.

Introducing A New Research Group

Underwater Technology

Research Group (UTeRG)

Dr. Mohd Shahrieel Bin Mohd Aras



Underwater Technology Research Group (UTeRG) is one of the research groups from Robotics and Industrial Automation (RIA) under The Center for Robotics and Industrial Automation (CeRIA). This research group is led by Dr Mohd Shahrieel Mohd Aras. This research group conducts research and development related to underwater technology, including the underwater platform which are the Unmanned Underwater Vehicle (UUV) (i.e Autonomous Underwater Vehicle (AUV), Remotely Operated Vehicle (ROV), Underwater Glider (UG), Underwater Crawler (UC), Surface Vessel)) and also the sensors used for underwater application such as Vision sensor, Depth Sensor, Hydrophone Sensor, Weather Station With PC Interface, GPS Tracker and etc. The research covers experimentation in the field of underwater research. This research group provides laboratory for testing, training and consultancy services to the industry. This group has collaborated with Underwater, Control and Robotics



Research Group (USM), Underwater Exploration Technology Research (MIMET-UniKL), Ocean Robotics Group (UMT), Center of Intelligent Signal and Imaging Research (UTP), Robotics & Unmanned Systems Research Group (UMP), Control & Instrumentation Research Group (UMP), Advanced Mechatronic Research Group (UTHM), Centre for Artificial Intelligence and Robotics (UTM), Physics Kit & Instrumentation Research Group (UPSI) and RoboTeam (IIUM).



Autonomous Underwater Vehicle (AUV)



Underwater Glider (UG)

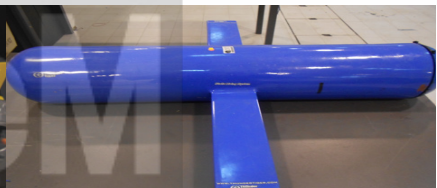

Remotely Operated Vehicle (ROV)



Underwater Crawler (UC)

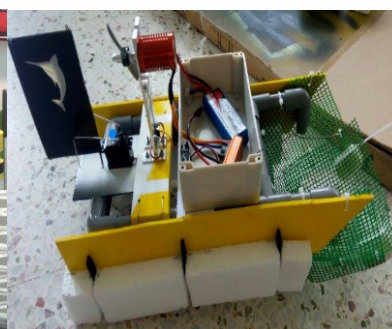
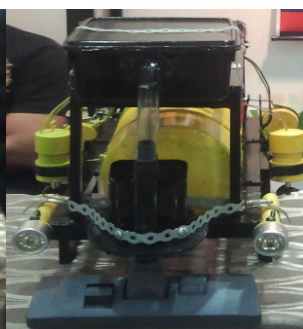

Pool & River Cleaning Robot



Integrated Ocean Observation System (IOOS) buoy



THE 4TH INTERNATIONAL CONFERENCE ON ENGINEERING AND ICT (ICEI 2016)

4TH - 6TH APRIL 2016 HATTEN HOTEL MELAKA, MALAYSIA

organised by  UTeM
UNIVERSITI TEKNIKAL MALAYSIA MELAKA

*"Pioneering Future Innovation
Through Green Technology"*





Faculty of Manufacturing Engineering

IDECON 2016

International Conference on Design and Concurrent Engineering

19 - 20 September 2016
Adya Hotel, Langkawi
Malaysia

IMPORTANT DATES

1 Dec - 30 March 2016	Submission of Full Papers
1 March - 30 May 2016	Notification of Acceptance
1 June - 1 July 2016	Registration Deadline
19 - 20 Sept 2016	Conference Day

PANEL OF REVIEWERS

- Prof. Dr. Shankar Kalivasundaram, ANU, AUSTRALIA
- Prof. Dr. Teruaki Ito, TU, JAPAN
- Prof. Dr. Xun W Xu, University of Auckland, NEW ZEALAND
- Prof. Dr. Elsayed Oraby, Michigan-Dearborn University, U.S.A
- Prof. Dr. Abdel Magid Hamouda, Qatar University, QATAR
- Prof. Dr. Che Hassan B. Che Harun, UKM, MALAYSIA
- Prof. Dr. Keith Case, Loughborough University, UNITED KINGDOM
- Prof. Ir. Dr. Hj. Mohd. Sapuan Sali, UPM, MALAYSIA
- Prof. Ir. Dr. Jahara Bin Abd Ghani, UKM, MALAYSIA
- Prof. Dr. Abdul Hakim Hakim, Inst. Teknologi Bandung, INDONESIA
- Prof. Dr. Ir. Isa Setiasyah Toha, Inst. Teknologi Bandung, INDONESIA
- Prof. Dr. Keith Popewell, Coventry University, U.K
- Prof. Dr. Razdli B. Othman, UTeM, MALAYSIA
- Prof. Dr. Megat Mohamed Hamdan, JPN, MALAYSIA
- Dr. Tegeeh Tjahjowibodo, NTU, SINGAPORE
- Dr. Maria Martin Desilva, Universidade de Sao Paulo, Brazil
- Prof. Dr. Jenny Harding, Loughborough University, UK
- Dr. Wan Abdul Rahman, SIRIM, MALAYSIA
- Prof. Dr. Zaidi Bin Isa, UKM MALAYSIA
- Prof. Kenjiro Miura, Shizuoka University, JAPAN
- Prof. Muhammad Saifraz, Kuwait University, KUWAIT
- Prof. Malik Zawwar Hussain, Punjab University, PAKISTAN
- Prof. Zulfaqr Habib COMSATS, PAKISTAN
- Prof. Dr. Baba B. Md Derus, UKM, MALAYSIA
- Prof. Mustafizal B. Rahman, UMP, MALAYSIA
- Prof. Intiaz Ahmed Choudhury, UM MALAYSIA
- Prof. Deok Sook Min, Hanyang University, KOREA

CONTACTS

Dr. Mohd Amri Bin Sulaiman +606 331 6451
 Dr. Resse Farahyan binti Munawar +606 331 6896
 Pn. Siti Norani Binti Dolah +606 331 6430
 Dr. Zuhriah Binti Ebrahim +606 331 6425

Fax +606 331 6411

Email : idecon@utem.edu.my

Address : Secretariat of IDECON 2016,
 Faculty of Manufacturing Engineering,
 Universiti Teknikal Malaysia Melaka (UTeM),
 Hang Tuah Jaya, 76100 Durian Tunggal, Melaka, MALAYSIA.

CONFERENCE REGISTRATION

Please complete this registration form, include details of payment and please return by fax (+606 331 6411) @ email (idecon@utem.edu.my)

1.0 PERSONAL PARTICULARS

Title : (Prof. /Assoc, Prof / Dr. / Mr. / Mrs. / Ms.)

Name :

Passport No. / I.C. No.:

Organisation / University:

Mailing Address:

City :

Tel:

Mobile:

Fax:

Email :

2.0 PAPER PRESENTATION

* Participant / Presenter

No. of Paper(s):

Title of Paper:

Supported by:



All registered papers will be published in SCOPUS indexed publications

<http://idecon2016.utem.edu.my/>

Registration Form Page 1



UTeM

UNIVERSITI TEKNIKAL MALAYSIA MELAKA



Always A Pioneer, Always Ahead

Universiti Teknikal Malaysia Melaka, Hang Tuah Jaya, 76100 Durian Tunggal,
Melaka, Malaysia.

www.utm.edu.my