

**EXPERIMENTAL STUDIES ON THE NOISE CHARACTERISTICS OF BALL
BEARING UNDER HEXAGONAL BORON NITRIDE (hBN) NANOPARTICLE
ADDITIVES IN ENGINE OIL**

MUNIR MOHAMMED MOHAMMED AL-GHAILI

B041310332

BMCL

muniralghaili@yahoo.com

Report

Projek Sarjana Muda II

Supervisor: DR. RAINAH BINTI ISMAIL

2nd Examiner: DR REDUAN MAT DAN

**Faculty of Mechanical Engineering
Universiti Teknikal Malaysia Melaka**

2017

DECLARATION

I declare that this project report entitled “EXPERIMENTAL STUDIES ON THE NOISE CHARACTERISTICS OF BALL BEARING UNDER HEXAGONAL BORON NITRIDE (hBN) NANOPARTICLE ADDITIVES IN ENGINE OIL” is the result of my own work except as cited in the references

Signature :

Name : MUNIR MOHAMMED MOHAMMED AL-GHAILI

Date :

APPROVAL

I hereby declare that I have read this project report and in my opinion this report is sufficient in terms of scope and quality for the award of the degree of Bachelor of Mechanical Engineering (Plant & Maintenance).

Signature :

Name of Supervisor : DR. RAINAH BINTI ISMAIL

Date :

DEDICATION

To my beloved family

ABSTRACT

The use of rolling element bearings is significant in most of the mechanical applications. Thus, the reliability and efficiency of the mechanical machines depends critically on the health of the rolling bearings. Vibration and noise generated by bearings are one of the big concerns in industry since they limit the performance of machines. Noise characteristics are to be determined for ball bearings lubricated with hexagonal Boron Nitride (hBN) nanoparticles additives in engine oil for different concentrations of concentrations of hBN namely 0.1%, 0.2%, 0.3%, 0.4%, 0.5%. A test rig consists of a motor that drive the system, coupling, rotor to support imposed loads and a bearing which its performance is to be validated. The overall performance has shown a reduction in noise level. Samples of hBN nano-lubricant with different % volume of hBN concentrations were prepared using ultrasonic homogenizing technique. Three conditions of ball bearing were investigated which are healthy bearing, inner defected bearing and outer defected bearing. Sound Level Meter was used to record the noise level for 10 minutes for each concentration and load condition and the average of the equivalent sound level for that period was calculated. The measurement of noise level has shown that the imposed load and concentration of hBN nanoparticles in the lubricant have a significant contribution to the noise level of the bearing. The noise level increases slightly with the increasing of unbalance imposed load while noise level decrease with addition of volume concentration of hBN nanoparticles.

ACKNOWLEDGEMENTS

In the name of Allah, the most Beneficent, and the most Gracious. Praises be to Allah, for blessing and granting me with the strength and patience I needed to finally and successfully complete my Final Year Project. I want to take this opportunity to thank everyone who helped me in achieving this project and I would like to express my deepest thanks to my supervisor DR. RAINAH BINTI ISMAIL for her essential supervision, support and encouragement towards the completion of this thesis. I also would like to thank my senior Kena for spending her time guiding me and sharing her knowledge. In addition, I would like to thank my parents who never scrimped on all types of support, whether psychological or physical.

I would like to thank my course mates for giving me their support, patience and encouragement. Finally, I would like to thank my family for their support.

CONTENT

CHAPTER	CONTENT	PAGE
	ACKNOWLEDGEMENTS	iii
	ABSTRACT	iv
	TABLE OF CONTENT	v
	LIST OF TABLES	vii
	LIST OF FIGURES	viii
	LIST OF ABBREVIATIONS	x
CHAPTER 1	INTRODUCTION	1
	1.1 Background	1
	1.2 Problem Statement	3
	1.3 Objective	3
	1.4 Scope of Project	4
CHAPTER 2	LITERATURE REVIEW	5
	2.1 Introduction	5
	2.2 Bearings	6
	2.2.1 Ball Bearings	7
	2.2.2 Roller Bearing	7
	2.2.3 Tapered Roller	8
	2.3 Diesel Engine Oil	9
	2.4 Hexagonal Boron Nitride (Hbn) Nanoparticles	10
	2.5 Studies on Nanoparticles Additives to Lubricants and Their Advantages	12
	2.6 Sound Level Meter	15

CHAPTER 3	METHODOLOGY	17
3.1	Introduction	18
3.2	Flow Chart	16
3.3	Development and Fabrication	19
3.3.1	Design Using SolidWorks	19
3.3.2	Fabrication of Test Rig	21
3.3.3	Fabrication of an Insulating Box	22
3.4	Sample Preparation	23
3.4.1	Calculation Of Hbn Mass Required For Each Concentration	23
3.4.2	Ultrasonic Homogenizing	26
3.5	Apparatus of Experiment	28
3.6	Experimental Procedures	29
CHAPTER 4	PRELIMINARY RESULTS	30
4.1	Introduction	30
4.2	Noise Behaviour Data	31
4.3	RESULTS & DISCUSSIONS	33
4.4	Noise Behaviour in Time Domain	39
4.5	Vibration Analysis	41
4.6	The Mechanism in Which Nanoparticles Additives Enhance Lubricants Performance	42
4.6	Summary	43
CHAPTER 5	CONCLUSION & RECOMMENDATION	45
5.1	Conclusion	45
5.2	Recommendations	46
	REFERENCE	47

LIST OF TABLES

Table	TITLE	PAGE
2.1	The chemical and physical properties of hBN.	11
3.1	List of the apparatus used during this experiment.	28
4.1	The equivalent sound level in dB at different loads and concentrations for Healthy bearing.	31
4.2	The equivalent sound level in dB at different loads and concentrations for inner defected bearing.	32
4.3	The equivalent sound level in dB at different loads and concentrations for outer defected bearing.	32
4.4	The reduction in equivalent sound level between 0.0% and 0.2% of hBN nanoparticles volume concentration.	38
4.5	Comparison for sound level in dB against time for the four loading conditions.	39-40

LIST OF FIGURES

FIGURE	TITLE	PAGE
1.1	Schematic diagram of a straight roller bearing (Gonzales, 2015).	1
2.1	Classification of bearings.	6
2.2	Ball bearings (Hyatt. 2009).	7
2.3 (a)	(a) Needle Roller Bearing.	8
2.3 (b)	(b) Straight Roller bearing.	8
2.4	Tapered roller bearings (Hyatt. 2009).	8
3.1	Flow chart of the general methodology (General Flow chart of FYP Methodology).	18
3.2	Design of test rig using SolidWorks.	19
3.3	Types of Bearing used during this study.	20
3.4	Welding process during the test rig fabrication.	21
3.5	Fabrication of insulating box.	22
3.6	Weighting of hBN powder using digital analytical balance.	23
3.7	Subtracting of oil.	25
3.8	The determined amount of hBN before being mixed.	25
3.9	The Ultrasonic Homogenizer model LABSONIC P made by Sartorius.	26
3.10	Fitting the position of the lubricant mixture inside the ultrasonic homogenizer.	27

3.11	The lubricant mixture (a) before homogenization and (b) after homogenization	27
3.12	Schematic diagram for the experimental apparatus.	29
4.1	The noise behavior in a healthy ball bearing with the average sound level in dB at different loads and hBN concentrations in engine lubricant.	33
4.2	The noise behaviour in inner defected ball bearing with the average of sound level in dB at different loads and hBN concentrations in engine lubricant.	34
4.3	The noise behaviour in outer defected ball bearing with the average of sound level in dB at different loads and hBN concentrations in engine lubricant.	34
4.4	The noise behavior in a healthy ball bearing with the average sound level in dB at different loads and hBN concentrations in engine lubricant.	35
4.5	The noise behaviour in inner defected ball bearing with the average of sound level in dB at different loads and hBN concentrations in engine lubricant.	36
4.6	The noise behaviour in outer defected ball bearing with the average of sound level in dB at different loads and hBN concentrations in engine lubricant.	37
4.7	The ball bearing parameters obtained from the vibration analysis.	42

LIST OF ABBEREVATIONS

hBN	Hexagonal Boron Nitride
SLM	Sound Level Meter
dB	Decibel
Leq	Equivalent Sound Level

CHAPTER 1

INTRODUCTION

1.1 Background

Bearing is a part of machine components that is designed to reduce the friction between the moving parts or to support moving loads. There are thousands of sizes, shapes, and kinds of rolling bearings such as ball bearings, roller bearings, needle bearings, and tapered roller bearings which are the major kinds. However, bearings can be classified into two main types, the antifriction type such as roller bearings and ball bearings which work on the principle of rolling friction. The second main type is the plain or sliding type, such as the journal bearing and the thrust bearing which work according to the principle of sliding friction. More studies and researches are being carried out in order to improve the bearing performance and reduce the noise and vibrations that it produces. One of the methods suggested is by adding hexagonal boron nitride (hBN) nanoparticles to the bearing lubricants. **Figure 1.1** shows a schematic diagram of a straight roller bearing.

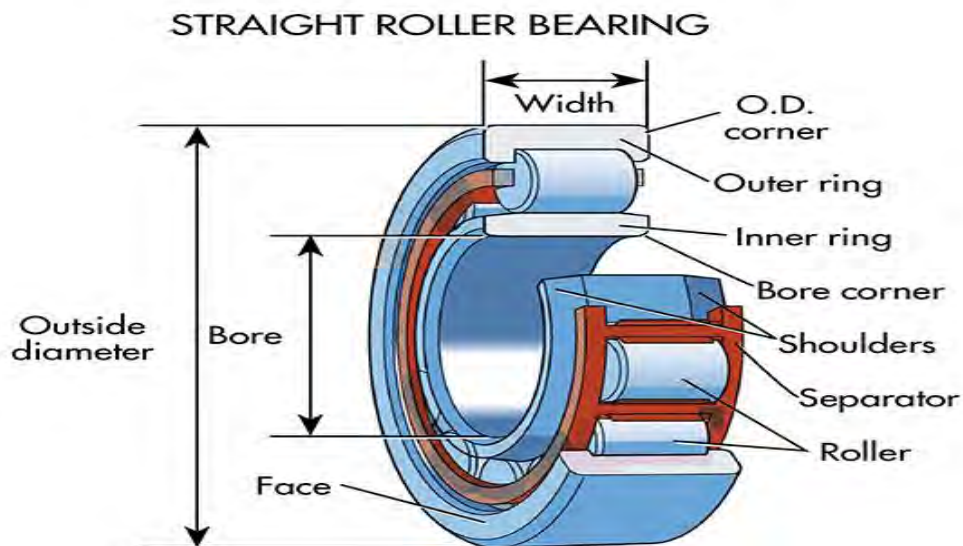

Figure 1.1: Schematic diagram of a straight roller bearing (Gonzales, 2015).

Basically, the main function of bearings is to reduce mechanical friction. Friction reduction enables machinery to run more efficiently and smoothly. Other advantages of bearing are extending the machinery life and, less frictional wear, and avoiding mechanical breakdown. Usually, Ball bearings are found in light precision machinery where high speeds are to be maintained, friction being is to be reduced by the rolling action of the hard steel balls. Bearings are usually lubricated with grease or oil in order to lower the frictional value. However, the friction is still relatively high which produce noise. Using the nanoparticles as additives and mixing them with the lubricants with certain concentrations would reduce the noise resulting from the bearings. The oil is continuously dragged in between the surfaces such that the bearing and the outer ring are separated from each other.

Hexagonal Boron Nitride (hBN) is a chemical combination of boron and nitrogen. Boron nitride exists in various forms, one of them is the hexagonal form that has the same structure as the graphite which is the most stable and soft and the most widely used. It's thermal and chemical stability properties make it useful at elevated temperature equipment. The low coefficient of friction makes it a good lubricant additive. Lubricants tribological properties can be enhanced in terms of wear and friction by addition of nanoparticles to the lubricants. Nanoparticles of hBN can significantly reduce the anti-wear and anti-friction properties for the base oil. Currently, many types of nanoparticles exist which are being used in industry such as hBN, CuO, Al₂O₃, TiO₂ etc.

Noise in bearings can be due to variety of sound sources that are unwanted by the customer. A source of noise in bearings is mainly due to the structural vibration and sound. There are several types of noise in bearings such as, race noise, click noise, squeal noise and cage noise and rolling passage vibration. Race noise is the basic sound in rolling bearings which is smooth and continuous sound and it gets louder with faster speed. The click noise is more apparent at large bearings under radial loads and it occurs at low speeds. Squeal noise is the metallic noise that sounds like a metal sliding on other metal and usually with grease lubrication. For the cage noise, it is either suggestive of the cage colliding with rolling elements or bearing rings or low frequency noise. The rolling element passage vibration is another factor of noise especially when operating under radial load, and it is mainly influenced by the radial clearance.

Other than the structural vibration and sound are the noise related to bearing manufacturing, improper handling, and contamination noise (Momono *et al.* , 1999).

1.2 Problem Statement

In the modern industrial applications, vibration and noise generated by bearings is one of the big concerns in industry since they limit the performance of machines. The addition of small amount of nanoparticles powder into the diesel engine oil as an additive contribute to the enhancement of bearings performance in terms of low friction and low vibration measurements. The different volume of concentration of nanoparticles gives different measurement of coefficient of friction and vibration level. However, there are no researches that studied about the performance of hBN in term of noise reduction. Thus, the characterization of noise level will be investigated to determine the behavior of noise for new and defected bearings operated under hBN nanoparticles mixed lubricant.

1.3 Objectives

The objectives of this project are:

1. To determine the noise characteristics of sound level and its behavior in time domain for ball bearings lubricated with hBN nanoparticle additives in engine oil through experimental means.
2. To determine the performance of hBN nanoparticles mixed lubricants in terms of noise reduction for different volume of concentrations of hBN namely 0.1%, 0.2%, 0.3%, 0.4%, 0.5%.

1.4 Scope of Project

The scopes of this project are to:

1. Prepare the samples of hBN nano-lubricant with different % volume of hBN concentrations using ultrasonic homogenizing technique.
2. Modify the existing test rig in order to make it compatible with our experiment requirements by replacing the motor and rotor.
3. Conduct experimental work in order to obtain the noise characteristics for ball bearing under various lubricant conditions by using sound meter level equipment.
4. Analyze the noise characteristics of the ball bearing under various lubricants conditions and study the performance by using Excel and MATLAB software.

1.5 Study outline

First, chapter 2 presents a critical review of the literature of Ball bearing, diesel engine oil, hBN nanoparticles as lubricant additives and Sound Level Meter. Second, chapter 3 illustrates about the methodology used to carry out the experimental measurements. It provides a detailed explanation starting from the SolidWorks design, development and fabrication, the preparation of lubricant samples by mixing conventional oil with hBN nanoparticles additives, experimental apparatus and ending with experimental procedures. After that, chapter 4 which provides the results of the experimental measurements that has been carried out to investigate the effects of the addition of hBN nanoparticles in terms of the noise produced by the ball bearing being investigated. It also provides comparison and analysis for the obtained experimental data. Finally, chapter 5 concludes this study and provides suggestions for potential future work.

CHAPTER 2

LITERATURE REVIEW

2.1 Introduction

Nanotechnology is considered as the 21st century's most revolutionary technology on which a molecular and atomic scale matter is manipulated. Many fields such as ushers and science of materials is brought into new era by nanotechnology. Lubricants tribological properties were among those fields in which a large number of investigations were carried out by addition of different nanoparticles to the lubricants. Addition of nanoparticles to lubricants was reported by many papers as an effective factor to reduce noise, friction and wear(Pisal *et al.* , 2014). Among the additives investigated was hexagonal boron nitride (hBN). However, the existed studies have not yet extensively explored the effectiveness of hBN nanoparticles additives in diesel engine oil. Current studies on the optimized hBN mixed with engine showed that friction was reduced and resistance against wear was increased. The reduction in friction would be attributed to the formation of boron oxide due to tribo-chemical reactions which results in a significant reduction in the rate of wear. Reduction in friction and rate of wear depends on nanoparticles characteristics such as concentration, shape and size which mostly range from 2 to 120 nm.(Abdullah *et al.* , 2015). The reduction in friction will result in a decrease on the level of noise produced by the operating machines which can be measured and analyzed to determine the performance improvement.

2.2 Bearings

For almost all rotating machinery, bearings are considered of paramount importance and are the machine elements most commonly used in industrial applications. If bearing failure occurred, it would cause machinery breakdown leading to significant losses. Therefore, it is essential to detect the bearing failure at early stages to prevent system breakdown (Xu *et al.* , 2016). Mechanical bearings are components used to reduce friction between two or more parts to allow their movement and enhance the performance. There are a wide variety of bearings as shown in **Figure 2.1** which are used and designed for specific functions and loads such as (1) ball bearings, (2) roller bearings, (3) tapered bearings, magnetic and fluid bearings as well. Some of the bearing types are:

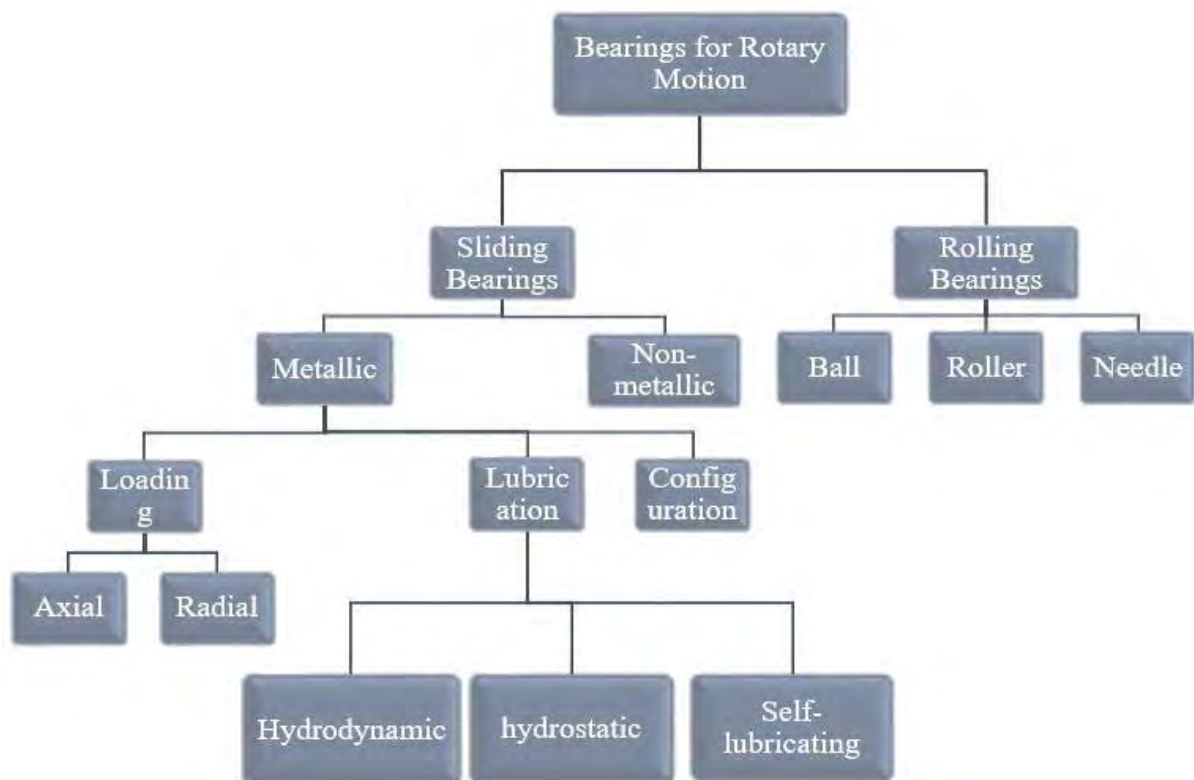

Figure 2.1 Classification of bearings.

2.2.1 Ball Bearings

Ball bearing are also called as anti-friction bearings which are the most common and used type of bearings exist in numerous applications in daily life. Ball bearings are made in small spheres to reduce the friction between axles and shafts in mechanical applications and usually used where the loads are relatively small otherwise balls will deform which ruing the bearing. The load is to be transmitted from the ball bearings outer surface to the inner surface through the ball which helps in smooth motion. **Figure 2.2** shows ball bearings type.



Figure 2.2: ball bearings (Hyatt, 2009).

2.2.2 Roller Bearings

Cylinders are used instead of spheres as in **Figure 2.3 (a)** in which the inner and outer race contact is line not a point like in ball bearings. Therefore, the contact area is larger which allows for greater loads. There are a variety of applications for roller bearings such as conveyer belts. Needle bearing is a special roller bearing. Needle bearings can be used where space is an issue. It can also bear higher radial loads. **Figure 2.3 (a) and (b)** shows roller bearing types.

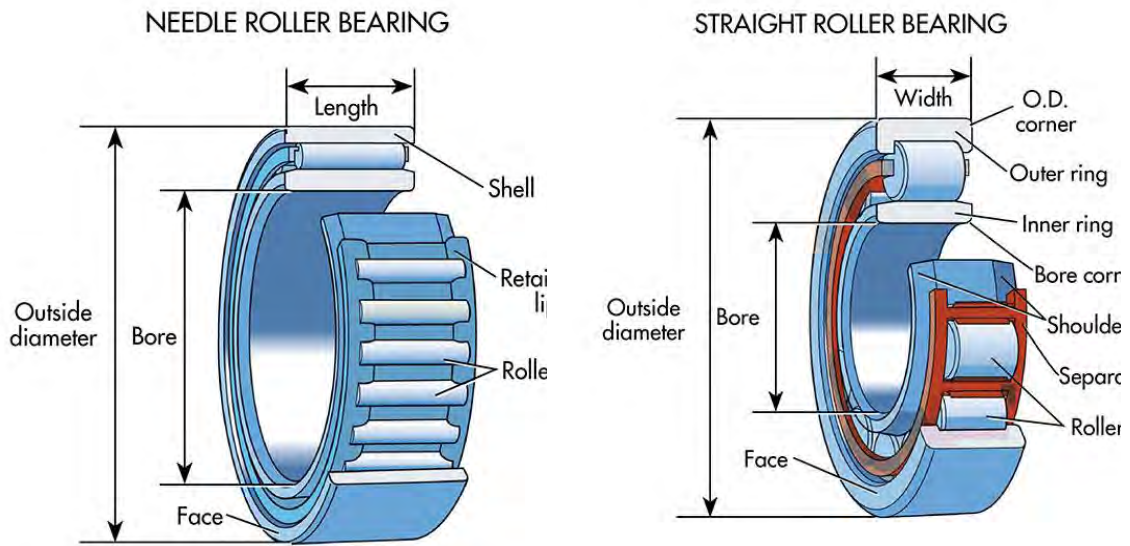

(a) Needle Roller Bearing

(b) Straight Roller Bearing

Figure 2. 3: Roller bearings (Gonzales, 2015).

2.2.3 Tapered Roller

Bearing which use conical rollers as shown in **Figure 2.4**. They can support both axial and radial loads and able to bear higher loads due to the larger contact patch. The geometry of those bearings distributes the speed equally along the contact patch which reduces friction and wear.



Figure 2.4: Tapered roller bearings.(Hyatt, 2009).

2.3 Diesel Engine Oil

Lubrication is of paramount importance for all vital parts of internal combustion engine to be lubricated in order to provide safe and undisturbed performance. As technology of engines goes for further development, lubricants need to be improved as well to get greater power from the engine and withstand higher wear, load, working temperature and last longer. Mineral engine oils were used at first, but to fulfill higher requirements, synthetic engine oils are implemented and globally gain the major market share. For an engine to function properly, some basic requirements need to be fulfilled: reducing friction, minimizing wear, assisting in cooling, and controlling depositions. The wear rate arises to the highest when starting the engine since the oil still not reached all critical parts of engine immediately. While the engine is operating, oil should not lose all of its viscosity, a proper thickness should be kept to provide adequate protection against wear for the engine (Ljubas *et al.*, 2010).

SAE 15W40 diesel engine oil is a heavy duty engine oil which is premium multigrade and synthetic diesel oil. It provides high performance for the diesel engines with higher ability to control deposits and wear. It is one of the purest in base oils with HT purity process of 99.9% purity. Purity has main role in maximizing oil's effectiveness and that can be achieved by controlling chemistry and additives to the system. Unburned fuel would mix in engine oil if not leaves the engine which is due to the uncompleted burn of fuel either in Otto or Diesel engines. This would cause partial or total dissolution for the fuel in engine oil which can result in contamination of the oil. As a result, viscosity, flash and fire point are essential to be analyzed.

2.4 Hexagonal Boron Nitride (Hbn) Nanoparticles

Hexagonal boron nitride (hBN) powder exists in white color with a lamellar crystalline structure that is similar to graphite which is black in color. The lattice parameters such as density and Mohs hardness of hBN are close to those of graphite, even though when it comes to lubrication effects, they have different effects (Pawlak *et al.* , 2009). hBN is distinguished with several unique engineering properties and uses such as improving the resistance to thermal shock by adding hBN to silicon nitride. This improvement is regarded to the micro cracks existed in between the basal planes in hBN. Another use of hBN is between layers of silicon filaments as a weak interface. The physical and mechanical properties vary with the concentration of hBN(Trice & Halloran, 1999). Beside the good thermal stability and the high rate of thermal conductivity hBN is an environmental friendly solid lubricant.

Based on a comparison made, line roughness and friction coefficient of the wear surface showed an optimal concentration for hBN nanoparticles of 0.1 %. Different tests have indicated that a small amount of hBN nanoparticles mixed with lubricant oil would improve the tribological performance including x-ray energy dispersive spectroscopic and atomic force microscopic analysis. However, the good influence of hBN as a lubricant additive has been rarely reported. Nanoparticles of BN could reduce significantly the anti-wear and anti-friction properties for the base oil (Wan *et al.* , 2015).

Today, with the advancement in nano-technology, studies on nanoparticles effects on tribological structure, reducing friction and anti-wear has rapidly increased. Several advantages have been reported by previous studies on the advantages of using nanoparticles as an oil advantages. Improving the friction coefficient by 14.4%, decreasing the wear rate by 65%, and enhancing the performance of lubricating oil can be achieved by the addition on hBN nanoparticles additives (Çelik *et al.*, 2013). The chemical and physical properties of hBN that were used in this project are shown in Table 2.

Table 2.1: The chemical and physical properties of hBN.

^a Properties	hBN nanoparticles
Appearance	White powder
Chemical formula	BN
Crystal structure	Hexagonal
Melting point, °C	3,000 dissociates
Average diameter particle size, nm	70
Density, kgm ⁻³	2.3
Hardness, HRC	40
Maximum use temperature in air, °C	1,000
Thermal conductivity, Wm ⁻¹ K ⁻¹	27
Thermal expansion coefficient @25-1000°C	1 × 10 ⁻⁶ /°C (parallel to press dir.)
Note: a. from manufacturer	

2.5 Studies on Nanoparticles Additives to Lubricants and Their Effects

The vibration suppression characteristics of ball bearing supplied with nano-copper oxide (CuO) mixed lubricant have been studied by (Prakash *et al.*, 2013) . During the their study of vibration suppression characteristics of ball bearing , a test rig consists of an operating DC motor, a ball bearing and the loading arrangement. Chemical methods were used to prepare the CuO nanoparticles. The base lubricants mixed with the CuO nanoparticles were added to the ball bearings to partially immerse the bearings and the radial vibration was measured. The experiment was repeated for CuO concentrations of 0.2%,0.5% and 1%. The results of the vibration test showed that the 0.2 % CuO nanoparticle mixture with base lubricant has effectively reduced the vibration level especially for the defected bearing comparing to the other concentrations.

(Patel *et al.*, 2014) aimed to investigate the vibration manners of healthy and defected deep groove ball bearings operating under dynamic radial loads. The experiment used a test rig of a rotating shaft supported by tow deep groove ball bearings. The ball bearings were lubricated and subjected to a dynamic radial load with varying frequency by an electromechanical shaker. Artificial circular defects with different sizes were made. An accelerometer was used to capture vibration signals. Presence of local defects enhances the overall vibration. Vibration peaks are gets more visible with the increase in defect size especially with local defects on outer race comparing to those of inner race defects.

Furthermore, investigation of the vibration behavior of roller bearings as a function of lubricant viscosity have been done by (Serrato *et al.* 2007). Rolling bearings of NU205 were tested using mineral oil as lubricant of three different viscosity grades ISO 10 (V1), ISO 32 (V2) and ISO 68 (V3). The tested bearing was oil bath lubricated and vertically loaded. A piezoelectric accelerometer was used to measure the bearing radial vibration. The measured signals were amplified and acquisitioned and finally analyzed. Vibration level is smaller as oil viscosity degree becomes higher, in contrast to the effect of temperature on oil viscosity.