



Faculty of Electrical Engineering
Universiti Teknikal Malaysia Melaka



LOK CHEE CONG

Bachelor of Mechatronics Engineering with Honours

2017

APPROVAL

I hereby declare that I have read this thesis and in my opinion this thesis is sufficient in terms of scope and quality for the award of Bachelor Degree of Mechatronic Engineering.

Signature :

Supervisor Name : DR. MUHAMMAD HERMAN BIN JAMALUDDIN

Date :

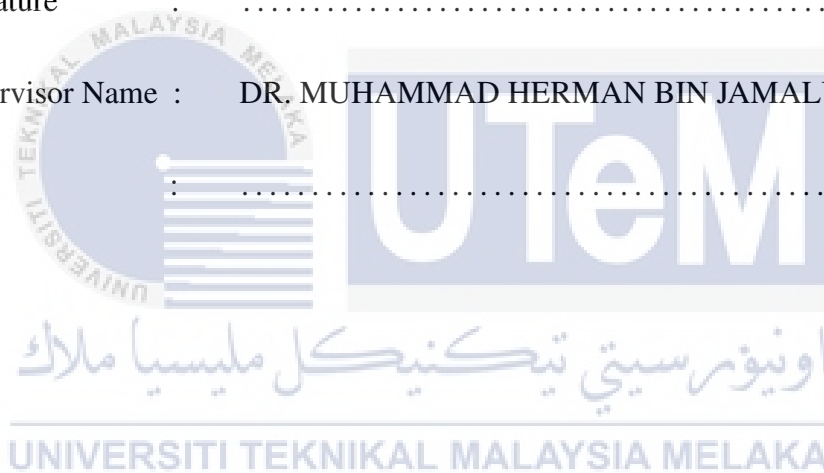

**DEVELOPMENT OF BILATERAL MASTER-SLAVE
TELEROBOTIC ARM MANIPULATOR SYSTEM**

LOK CHEE CONG



**A report is submitted in partial fulfilment of requirements for the
Bachelor of Mechatronics Engineering with Honours**



UNIVERSITI TEKNIKAL MALAYSIA MELAKA

Faculty of Electrical Engineering

UNIVERSITI TEKNIKAL MALAYSIA MELAKA

2017

DECLARATION

I declare that this thesis entitle "DEVELOPMENT OF BILATERAL MASTER-SLAVE TELEROBOTIC ARM MANIPULATOR SYSTEM" is the result of my own research except as cited in the references. The thesis has not been accepted for any degree and is not concurrently submitted in candidature of any other degree.

Signature :

Name :

Date :



اونيورسيتي تيكنيكل مليسيا ملاك

UNIVERSITI TEKNIKAL MALAYSIA MELAKA

DEDICATION

To my beloved lovely family

Thank you for your unconditional love and spiritual support.

Your sacrifices and loves have helped me in accomplish this achievement.

Dear supervisor and lecturers

Thank you for your support, helping, knowledge and guidance.

Dear friends

Thank you for your encouragment, support, and selflessness sharing.



اونيورسيتي تيكنيكل مليسيا ملاك

UNIVERSITI TEKNIKAL MALAYSIA MELAKA

ACKNOWLEDGEMENTS

First and foremost, my greatest gratitude to my supervisor, Dr. Muhammad Herman bin Jamaluddin for his dedicated teachings, resourceful knowledge and his selflessness guidance in helping me completing this thesis. Gratefully thanks for his advice and sharing his expertise knowledge in bilateral telerobotic system. Special thanks to UTeM FKE for providing source and facilities for this excited exploration journey. I would like to thank to my lovely family for supporting me all the way to complete my tertiary education. Without them, I would not have accomplish what I have achieved today. Lastly, I would like to thank my coursemates and friends for their encouragement along the journey. Also, thanks to their suggestion and feedback about my project and keep me improving this project. Lastly, I would like to thanks everyone who has giving their concern and support during the process of completing this research and thesis.



ABSTRACT

Bilateral master-slave telerobotic arm manipulator system is an advanced technology used to help human to interact with environments that are inaccessible to human, due to its remoteness or hazardous. The system has been used in different areas such as telesurgery, exploring space or sea exploration, and handling hazardous or explosive material. It is useful for development of science and society, however there is still not a common technology in Malaysia. The problem statement of this project is the time-delay occurred in a bilateral master-slave telerobotic arm manipulator system has degraded the system performance. Moreover, there is still do not have researchers implement the bilateral master-slave telerobotic arm manipulator system to an industrial robot in Malaysia which could be useful to the industrial development. Hence, objective of this project are to study the bilateral master-slave telerobotic arm manipulator system, develop it and applied it on industrial robot which is KUKA youBot, and finally analyse the performance and time-delay. However, in this thesis, it will present a development of bilateral master-slave telerobotic arm manipulator system to an industrial robot which is Kuka youBot in a simulation only. In methodology, simulation is carried out by using two software which are V-REP and python. Three controllers are used which are P, PD and PID on this system to compare their effect on the system. In the result, common mode and differential mode of bilateral system have been proved in the experiments. The result of experiments showed that the overall accuracy of the designed system is over 95% and time-delay between master and slave robot is merely about 0.2s, which showed a good performance. Through experiments, the best controllers have been chosen and the best value of proportional, derivative and integral term for controller has been identified. At last, through experiment findings, the best controllers to be used are PD and PID controller which PD controller is better in accuracy whereas PID controller has shorter time-delay. Hopefully, this research might give a little contribution to whether the education, industrial or society.

ABSTRAK

Sistem dua hala 'master-slave' telerobotik adalah teknologi yang canggih dan banyak digunakan untuk membantu manusia berinteraksi dengan persekitaran yang tidak dapat dicapai oleh manusia. Faktor manusia tidak mampu mencapai persekitaran itu boleh disebabkan terpencil atau berbahaya. Sistem ini banyak dilaksanakan pada pelbagai bidang iaitu telepembedahan, penerokaan angkasa atau laut dalam, dan pengendalian bahan berbahaya dan bahan letupan. Teknologi ini amat memanfaatkan social dan memajukan bidang sains negara, malah teknologi ini masih tidak banyak diberi perhatian di Malaysia. Pernyataan masa projek ini adalah penangguhan masa menyebabkan sistem dua hala ini tidak stabil. Selain itu, tiada penyelidik pernah melaksanakan teknologi sistem telerobotik ini dalam robot industri yang dapat memanfaatkan pembangunan bidang industri. Oleh itu, objektif tesis adalah mempelajari sistem dua hala 'master-slave' telerobotik ini, membinakan sistem ini dan membuat analisis tentang prestasi dan penangguhan masa. Bagaimanapun, dalam tesis ini, sistem ini akan dibentangkan dalam simulasi sahaja. Dalam projek ini, V-REP dan python akan digunakan untuk simulasi ini. Pengawal P, PD dan PID akan digunakan untuk berbanding prestasi dengan sama satu lain. Keputusan eksperimen menunjukkan ketepatan keseluruhan adalah melebihi 95%. Melalui eksperimen, sistem pengawal yang terbaik untuk sistem ini telah dipilih. Pengawal PD dan PID adalah terbaik untuk digunakan dalam sistem dua hala 'master-slave' telerobotik ini, pengawal PD lebih baik dalam ketepatan malah pengawal PID memiliki penangguhan masa yang lebih pendek. Harapan penyelidikan ini dapat memberi sedikit sumbangan kepada bidang pendidikan, bidang industri atau social masyarakat.

TABLE OF CONTENTS

Approval	i
Declaration	iii
Dedication	iv
Acknowledgements	v
Abstract	vi
Abstrak	vii
Table of Contents	viii
List of Figures	x
List of Abbreviations	xiii
List of Symbols	xiv
CHAPTER 1 INTRODUCTION	1
1.1 Overview	1
1.2 Problem Statement	1
1.3 Motivation	2
1.4 Objective of Project	5
1.5 Scope of Project	5
1.6 Summary	6
 CHAPTER 2 LITERATURE REVIEW	
2.1 Overview	7
2.2 Master-slave Telerobotics System Overview	7
2.3 Requirement in Telerobotics System	10
2.4 Challenges in Telerobotics System	10
2.5 Proposed Solution	11

2.6	Analysis Method	16
2.7	Summary	17
CHAPTER 3 RESEARCH METHODOLOGY		
3.1	Overview	19
3.2	Designation of Control System	20
3.3	Implementation of Bilateral Master-Slave Telerobotic Arm Manipulator System in Simulation	24
3.4	Experiment and Analysis	31
3.5	Summary	37
CHAPTER 4 RESULT AND DISCUSSION		
4.1	Overview	38
4.2	Part 1: Result for Common Mode Verification	38
4.3	Part 2: Result for Differential Mode Verification and Performance between different Controllers	41
4.4	Summary	56
CHAPTER 5 CONCLUSION AND RECOMMENDATION FOR FUTURE RESEARCH		
5.1	Conclusion	57
5.2	Future Work	58
REFERENCES		59
APPENDICES		61

LIST OF FIGURES

		Page
Figure 1.1	Statistics shows graph about number of mines in different countries.	3
Figure 2.1	Basic components of telerobotics system.	8
Figure 2.2	Haptic sense and haptic communication through network.	8
Figure 2.3	Basic of robotic system.	9
Figure 2.4	Example of closed-loop teleoperation of surgery which control unit is between master and slave arm.	10
Figure 2.5	Four channel transmission architecture.	11
Figure 2.6	Block diagram of DOB and RTOB.	14
Figure 2.7	Architecture of telerobotics system which involved 5 basic elements. F denotes force and V denotes velocity. The subscripts h,e,m and s represent the operator, environment, master and slave respectively.	17
Figure 3.1	Flow Chart of the Research	19
Figure 3.2	Block diagram of Motor.	20
Figure 3.3	Block diagram adding P control to the manipulator system.	21
Figure 3.4	Block diagram adding PD control to the manipulator system.	22
Figure 3.5	Block diagram adding PID control to the manipulator system.	23
Figure 3.6	Scene object properties of KUKA youBot joint setting in V-REP.	24
Figure 3.7	Joint dynamic properties of KUKA youBot joint setting in V-REP.	25
Figure 3.8	Scripts setting of KUKA youBot in V-REP.	26
Figure 3.9	Programming code in threaded child script of V-REP .	26
Figure 3.10	Programming code in Python.	26
Figure 3.11	Simulation of single KUKA youBot with command robot to rotate 90 degree.	27
Figure 3.12	Block diagram of bilateral telerobotic arm manipulator.	28

Figure 3.13	Simulation of two KUKA youBot with command master robot to rotate 90 degree.	29
Figure 3.14	Simulation of two KUKA youBot (master robot at left and slave robot at right) with a cylinder is placed to block the slave robot.	29
Figure 3.15	An external arm is created by using V-REP software to act as external force.	32
Figure 3.16	An obstacle is used to block the way of slave youBot arm when it is moving.	33
Figure 3.17	Master and slave is moved without any obstacle.	34
Figure 4.1	Force data from master and slave arm with the maximum torque of 5N.	39
Figure 4.2	Force data from master and slave arm with the maximum torque of 15N.	39
Figure 4.3	Force data from master and slave arm with the maximum torque of 25N.	40
Figure 4.4	Angle of from master and slave arm rotated from its original position with value of $K_p=1$.	42
Figure 4.5	Angle of from master and slave arm rotated from its original position with value of $K_p=5$.	42
Figure 4.6	Angle of from master and slave arm rotated from its original position with value of $K_p=8$.	43
Figure 4.7	Angle of from master and slave arm rotated from its original position with value of $K_p=10$.	43
Figure 4.8	Angle of from master and slave arm rotated from its original position with value of $K_p=20$.	44
Figure 4.9	Angle of from master and slave arm rotated from its original position with value of $K_p=50$.	44
Figure 4.10	Angle of from master and slave arm rotated from its original position with value of $K_p=1$ and $K_d=0.8$.	47
Figure 4.11	Angle of from master and slave arm rotated from its original position with value of $K_p=5$ and $K_d=0.1$.	47
Figure 4.12	Angle of from master and slave arm rotated from its original position with value of $K_p=8$ and $K_d=0.5$.	48

Figure 4.13	Angle of from master and slave arm rotated from its original position with value of $K_p=10$ and $K_d=0.2$.	48
Figure 4.14	Angle of from master and slave arm rotated from its original position with value of $K_p=20$ and $K_d=1.6$.	49
Figure 4.15	Angle of from master and slave arm rotated from its original position with value of $K_p=50$ and $K_d=4.65$.	49
Figure 4.16	Angle of from master and slave arm rotated from its original position with value of $K_p=1$, $K_d=0.8$ and $K_i=0.01$.	51
Figure 4.17	Angle of from master and slave arm rotated from its original position with value of $K_p=5$, $K_d=0.1$ and $K_i=0.001$.	52
Figure 4.18	Angle of from master and slave arm rotated from its original position with value of $K_p=8$, $K_d=0.5$ and $K_i=0.005$.	52
Figure 4.19	Angle of from master and slave arm rotated from its original position with value of $K_p=10$, $K_d=0.2$ and $K_i=0.0005$.	53
Figure 4.20	Angle of from master and slave arm rotated from its original position with value of $K_p=20$, $K_d=1.6$ and $K_i=0.005$.	53
Figure 4.21	Angle of from master and slave arm rotated from its original position with value of $K_p=50$, $K_d=4.65$ and $K_i=0.05$.	54

LIST OF ABBREVIATIONS

API	Application Programming Interface
DOB	Disturbance Observer
LAN	Local Area Network
LED	Light Emitting Diode
PC	Personal Computer
RFOB	Reaction Force Observer
ROS	Robot Operating System
WOB	Workspace Observer



LIST OF SYMBOLS

θ angle in radians

f_m force of master manipulator

f_s force of slave manipulator

G_r Gear Ratio

I_a Torque electric current

J_m Inertia of the motor shaft

K_d Derivative Gain in PD controller

K_p Proportional Gain in PD controller

K_t Torque constant

x_m angle in radians

x_s angle in radians



CHAPTER 1

INTRODUCTION

1.1 Overview

In the overview of introduction section, it covers the topic explain about motivation, problem statement, objective and scope of project.

1.2 Problem Statement

Bilateral master-slave telerobotic is a potential useful tool for human in complete some difficult task. The efficiency of the master-slave robot in term of synchronizaton of position between master and slave arm and time-delay depends on the accuracy required from the tasks. However in stability analysis and the study of control design of teleoperation system, a main problem is still remained which is the time-delay. In the complexity of communication network between computer and master-slave telerobotics system, time-delay is unavoidable during the data packet exchanged between master and slave robot.[1].

Nevertheless, the time-delay of data transimission in telerobotics system becomes larger when the distance between the master robot and slave robot become further. Telerobotic arms always involve in haptic technology, this is because the sense of human is important to let the human operator 'feel' as close as it is happens on the remote environment. The force-feedback system is applied in the master-slave telerobotic arms, often the tranmsission data time from master to slave robot which called forward time-delay is different with the transmission data duration from slave to master robot which called backward time-delay. This kind of time-delay is described as time varying delay. Moreover, the time-delay is not

only varying but also asymmetric due to the complexity of the communication network[2]. As a result, the application of remote control of bilateral master-slave telerobotic system, the time-delay problem could cause destabilisation and degrade the tracking performance of closed-loop telerobotic system[3].

Hence, it is still an open problem awaiting researchers and experts to solve and design a stabilising control system for internet-based telerobotic systems for which communication delays are time-varying and asymmetric. Over the years, there are few researchers have proposed some control methods in the paper to solve the problem of time delay in network-based telerobotic systems, the examples are from[4],[5], and many others. But then there is still do not have a perfect solution in reducing the time delay problem. Also, there is still do not have a bilateral master-slave telerobotic arm manipulator system being developed and applied on an industrial robot yet.

In conclusion, development of bilateral master-slave telerobotic arm manipulator system in an industrial robot is proposed in this thesis to analysis the time-delay and the performance of robotic arm system in term of accuracy and efficiency.

1.3 Motivation

Bilateral master-slave telerobotic arms have become an emerging technology in this century. This technology is important because it can helps human to interact with environments that are not accesible to human, it could due to the remoteness or hazards environment. There are five basic parts involved in a master-slave telerobotics system which include human operator, master robot, slave robot, communication channel and the environment. In real world problem, there are many special task cannot be easily completed by human being, these made the remote bilateral teleoperation technology has many potential applications.

The motivation of improving bilateral master-slave telerobotic arms manipulator system come from few reasons, which is saving life, to be used in further human's exploration, and improve the industrial performance. Bilateral master-slave telerobotic that involve saving life include it can helps human to handle hazardous and dangerous object and robotic telesurgery has become more famous in the medical industry. On the another hand, bilat-

eral master-slave telerobotics arms can be used in exploration such as space and undersea exploration which is not easy to be accessed by human.

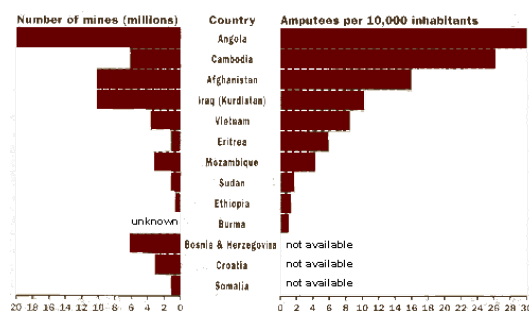

Figure 1.1: Statistics shows graph about number of mines in different countries.

From research statistic provided by [6], there is approximately 110 million active mines dispersed all over 70 countries as shown in Figure 1.1. In short, there is one for every 52 humans in our world. Also, it mentioned that every month, there are estimated 2,000 victims are involved in landmine accidents. In other words, there is one people involved in the accident every 20 minutes. Among the victims, about 800 will passed away, the remain will be maimed. Besides, from the statistics, for every 5,000 mines cleared by deminer, one will be killed and two will be injured. So far, there are approximately 100,000 mines are eliminated every year, but unfortunately until recently, 2 million mines were still being planted. According to the rate of demining, to get rid of all the mines in the world, it would take about 1,100 years. Also, statistics stated that majority of the death are involved men soldier, which is 76% in Afghanistan and 80% in Cambodia. However, in some countries, over 30% of the casualties is women and children. This incident happened because of the coincides with a period of refugee returning to mined areas, and this makes the number of casualties of civilians overwhelming. There is a case that happened in 1991 in northern Somalia, children whose born to be playfulness have made up of 75% of mine victims, this put vulnerable children a great risk. It is approximately 80% life of children cannot be saved before reaching a hospital. Moreover, there is 80% death in the mine accident is civilians in Georgia (1994-1995), 68% in Mozambique (1994), and 88% is in Namibia (1980). Hence, it is utmost important that the development of bilateral master-slave telerobotics system in a help to reduce the unnecessary casualties by replacing human to de-mine the implanted mine.

According to statistic provided by [7], a report named "To Err Is Human" which is

published by the Institute of Medicine stated that there is up to about 98,000 people each year die due to the mistakes in hospitals. This report have shocked the medical community due the overwhelming number in the statistic. At the beginning, the number is being doubted and argued, but now is widely accepted by medical community in 2014, and quoted often in the media.

In short, based on the statistical data given above and mentioned global issues, it is obviously shown that the development of bilateral master-slave telerobotic arms is utmost important for the a better future to the next generation. This is to help people to perform the difficult task without scarifying human life. In addition, the Office of Inspector General for Health and Human Services mentioned that 180,000 patients is dead in Medicare in year 2010 due to bad hospital care. Unfortunately, in a recent study, an issue that stated by Journal of Patient Safety, it mentioned that the numbers of patients between 210,000 and 440,000 who go to the hospital suffered the preventable harm and cause to death has increased. Among the case, 20% of the death are caused by operation mistake did by inexperienced doctor. This medical errors have contributed the cause of death in America become the third-leading killer, just behind heart-disease and cancer, which is the first place and the second respectively.

اونيورسيتي تيكنيكل مليسيا ملاك

UNIVERSITI TEKNIKAL MALAYSIA MELAKA

1.4 Objective of Project

Objectives of this project include:

1. To study bilateral master-slave telerobotic arm manipulator system.
2. To develop bilateral master-slave telerobotic arm manipulator system.
3. To analyse the time-delay and performance of the bilateral master-slave telerobotic arm manipulator system.

1.5 Scope of Project

Scope or limitation of this project include:

1. The bilateral master-slave telerobotic arm manipulator system is designed and tested in simulation only.
2. The bilateral master-slave telerobotic arm manipulator system is only applied to Kuka youBot.
3. The bilateral master-slave telerobotic arm manipulator system is applied on the identical master and slave robot arms.
4. The bilateral master-slave telerobotic arm manipulator system's motion is restricted to linear motion of joint 1 for KUKA youBot arm only.
5. The bilateral master-slave telerobotic arm manipulator system do not have the micro-macro scaling function.
6. The trajectory planning and accuracy of robotic arm reach to the desired coordinate is not in the scope of this project.
7. Compensation of friction force is not in the scope.

1.6 Summary

As a conclusion of this section, this section had briefly mentioned about the motivation of this project, problem statements, objective and scope of this project. In the next section, it will cover about the literature review which discuss about the methods in the past work research.



CHAPTER 2

LITERATURE REVIEW

2.1 Overview

This chapter delves into the past works of robotic system with an overview of the bilateral master-slave telerobotics system. This chapter also touches requirement needed in bilateral master-slave telerobotics system, challenges in implementing telerobotics system, proposed control system from past works, and the analysis methods. At the end of this chapter, the summary of this chapter is presented.

2.2 Master-slave Telerobotics System Overview

In [2], it mentioned that the master-slave bilateral telerobotics system is useful to human because the technology enable human to interact to the environment that is not easy to approach due to its remoteness and dangerous. This technology is useful and important because from [3], it explained that this technology with the remote operation functionality, brings up benefit to human with various potential application. For example, exploration to an un-accessible place like space exploration and sea exploration. Moreover, bilateral master-slave telerobotics technology also can be useful in telediagnosis and telemedicine which improve the level of health among humans. Lastly, this technology can avoid human to be sacrificed in handling of dangerous material such as demining and nuclear leak. A basic components needed in a telerobotics system is shown in Figure 2.1 which it consists of a human operator, master robot, slave robot, a communication channel and lastly the environment[2].

In master-slave telerobotics system, haptic technology carries one of the important

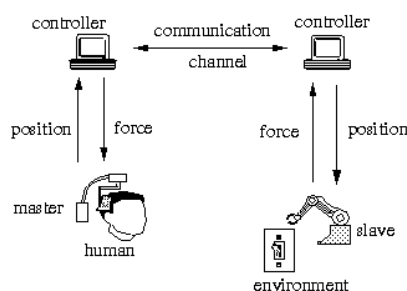

Figure 2.1: Basic components of telerobotics system.

role to make the system useful. In human daily activities have involved haptic sense nowadays. The purpose of haptic technology is the establish a bridge between human and unknown environment. This sense is just similar with the auditory and visual senses, the invention of telephone extends human hearing communication while the creation of television or webcam has provide a better visual communication to human. Currently, haptic communication is a challenging technology to extend human touch sense in various applications such as telesurgery, nuclear engineering, cell injection and space exploration[8].

Haptic sense is different from other senses, it occurs bilaterally: it worked by a human applying a motion to an environment, the reaction force is feedback and cause the human feeling the distortion of the environment. Hence, a mechatronics system and a bilateral control system is needed to implement the haptic technology. In a basic haptic system, the hardware should consists of a master robot, a slave robot, and a communication channel which allow the motion and force data could be transmitted along the master and slave robot. The system is shown in Figure 2.2.

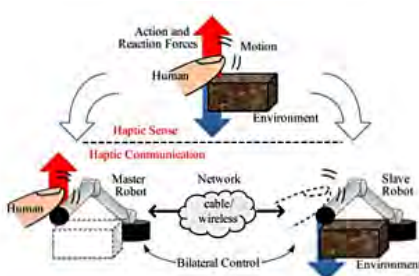

Figure 2.2: Haptic sense and haptic communication through network.

However, in this paper, not only the communication and synchronization of movement between master and slave arms are focused, but the haptic technology or force feed-

back is also emphasised. To implement the locomotion of robot arm, the robot basically has a close loop system as shown in Figure 2.3 refer from [9].

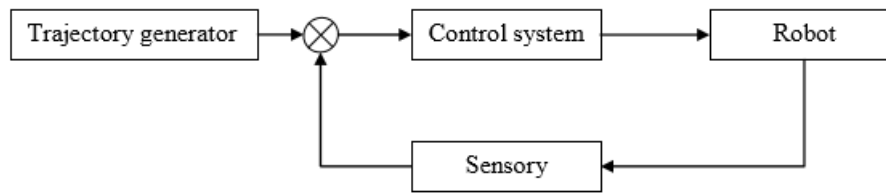

Figure 2.3: Basic of robotic system.

From Figure 2.3, the system trajectory generation where the system generates position, velocity, or acceleration profile. There are two types of trajectory generation, which is 1) Joint space schemes where the trajectory generated is implemented to joint and 2) Cartesian space scheme where the trajectory generated is the motion of a point in space. Both types are used a cubic polynomial function with certain, and the higher the polynomial order, the smoother the motion becomes. To reduce the complexity, trajectory planning is not in the scope in this paper, rather than assign the robotic arms to reach a precise location, this paper only study the communication and how close could slave arm follow the motion of its master arm. Thus, only simple linear motion will be implemented in this paper.

From Figure 2.3, the system will undergo a control scheme after a motion trajectory has been generated. In this scheme, comparison between the trajectory given with the input from the sensory units is made to ensure the actual trajectory is always the same as the generate trajectory from the trajectory generator. There are many types of control such as PID, PD, Fuzzy, artificial neural network(ANN) and state feedback. Those control system will make adjustments or corrections based from the sensory feedback that is usually embedded in the robotic system. However, ensuring the actual trajectory is same as planned is not in the scope of this paper. Instead of inserting control system among a robot arm itself, the control design in this paper is implemented between the master and slave arm along the communication channel as shown in Figure 2.4 to ensure synchronization master-slave arms.

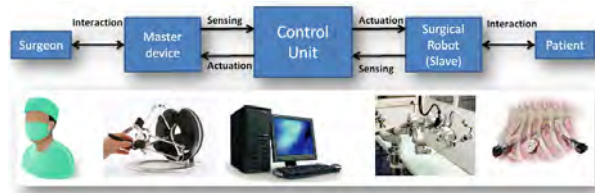

Figure 2.4: Example of closed-loop teleoperation of surgery which control unit is between master and slave arm.

2.3 Requirement in Telerobotics System

In master-slave telerobotics and haptic communication system, the key issue is about transparency to make the system realised[10]. In a bilateral telerobotics system, transparency is an evaluation index[11]. Definition of transparency is that there is matching impedance between human operator from master system and environment impedance from slave system. In more technical way, the meaning of high transparency reflects that both master and slave robot have achieved the high accuracy of force and position control, i.e. $f_m = -f_s$ and $x_m = x_s$, where f_m means the external force exerted on a master robot, f_s denotes that external force exerted on a slave robot, x_m means the position of master robot and x_s means the position of the slave robot.

Normally, force and position parameters between the master and slave is often used in the bilateral master-slave telerobotics system control. Besides of transparency, [11] mentioned about that a quality of communication is affected by the robust stability. The stability is defined as there is no oscillation or overshoot at the positions and forces between master and slave. Hence, stability of a telerobotics system is important so that a system always has a stable performance.

2.4 Challenges in Telerobotics System

To achieve a high transparency and robust stability telerobotics system, the communication channel and control system carries an important role. In stability analysis and wireless telerobotics system's control design, time-delay is still remain a critical problem[1]. In the communication of telerobotics system between robots and computer, the time-delay transmission of data packet between them can hardly be avoided.

In the force-feedback of telerobotics system, the time delays of signal sending from master to slave arm (forward signal) and the signal sending from slave to master arm (backward signal) are always different. Hence the time-delays often vary. Furthermore, the presence of transmission delays can be caused by several factors including long satellite transmissions, low-bandwidth transmission lines, and slow acoustical connections. Hence, the delay in transmission of data between master and slave robot is often time varying and asymmetric [2]. As a result, the time delay problem will degrade and destabilise the tracking performance of a close-loop telerobotics system [3]. Thus, researchers are still finding a control method to solve this open problem in order to reduce the time delay and ensure the transparency of a master-slave telerobotics system.

2.5 Proposed Solution

According to the challenge of the bilateral master-slave telerobotics arm mentioned in the last section, there are many researchers mentioned in [12] who proposed different kinds of control methods to try to deal with the stability and transparency problem. Firstly, passivity-based control has been developed to enforce the stability of a telerobotics system; the Figure 2.5 shows the four channel transmission architecture, which is developed to achieve good transparency performance.

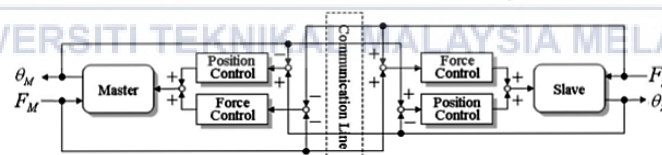

Figure 2.5: Four channel transmission architecture.

In addition, adaptive control is developed by researchers to deal with the parameter variations in master and slave robots. Besides, to avoid using acceleration measurements, researchers have proposed to use the virtual master manipulator. Then the following control method is specially to tackle the communication time delay problem. Many researchers have taken attention in the designation of telerobotics control in recent years. Firstly, to guarantee the system passivity under time delay, researchers have developed the scattering approach and wave variable formulation.

Furthermore, there is a method called sliding model control is created to solve the

modelling uncertainties of the system dynamics. Besides, the designation of passivity analysis of 2-port networks is being used to achieve the system's robust stability. However, for all these passivity-based control method it has its limitation, which is mostly focus on stability analysis rather than achieve the guaranteed performance in the same time. To deal with the time delay issues, model predictive control has been developed. But this control system have its disadvantages which is the system needs to know the system dynamics parameter such as time delay constant and model parameters. This result the system needs a high cost spent to the prior system identification and it may sensitive to the modelling uncertainties either, which make this system not realistic. On the other hand, Leung and Francis proposed a μ -synthesis-based robust controller. The assumption has been made that time delay is a perturbation to the telerobotics system. However, this assumption could not be used at large time delay. Some researchers have tried using artificial intelligent method such as artificial neural network (ANN) and fuzzy logic, which mostly involve adaptive skills and integrates linear matrix inequalities (LMI) in order to solve the time delays and various uncertainties.

In 1990s, disturbance observers (DOBs) were proposed to used in master-slave telerobotics system. DOB is a system where the model uncertainties and the external disturbances are all lumped together as an error term. Then the error term is compensated in the control design through a low-pass filter. The estimated disturbances are fed-back in the inner-loop to guarantee the robustness of the motion control system. The DOB method is widely used in many applications because it has the advantages of simple design, effective observation and its ability to compensate the disturbances, modelling errors and reaction force. The bandwidth of the DOB is always set as high as possible to estimate and suppress a wide range of disturbances' frequency.

Previously, force sensor is used on both master and slave robot to detect the force while contact to some objects, and giving force feedback value in order to achieve bilateral teleoperation. However, force sensor is not implemented in bilateral telerobotic system nowadays, this is because the characteristic of force sensor has narrow bandwidth. This narrow bandwidth could bring negative effect on the transmission of force data in a result affect the stability of the whole bilateral telerobotic system. In addition, force sensor have its own signal noise and natural frequency which will deteriorate the performance of control system. Another limitation of using force sensor is the external force could only be detected at the

position where the force sensor is being installed. As a result, force sensor may not be able to sense the force when there is a deviation of position. The force measurement without sensor brings up convenience to applications such as space or underwater explorations, where the force sensor is very difficult to be setup, or it may cost a lot to make it realisable. In bilateral master-slave telerobotics system, the role of DOB is to estimate the lumped disturbance of robotic manipulators. The lumped disturbance included friction, external disturbances, and the effect of the dynamic uncertainties which then becomes a feedback to the input for control system.

Generally, there are two types of observers that can be used in the system. The first is DOB which is used to reject the unnecessary disturbance, whereas the other one is reaction force observer (RFOB) which is used to estimate the unmeasurable environmental force. RFOB is designed by subtracting the system uncertainties and external disturbances from input of DOB. RFOB is somehow similar with DOB, however only RFOB has model based control structure. Moreover, both constant delay or time-varying delay can be compensated by using developed communication DOB. Although DOB has so many benefits, there is still its limitation. Since the equivalent network disturbance cannot be easily assumed to be bounded, the system could not work well at large time delay.

Figure 2.6 shows the block diagram of single arm manipulator system using DOB and RFOB controller. The reason of PD controller is used instead of PID controller is that this DOB and RFOB have replaced the job of integrator(I), which is more effective for motion control and robust to both parameter uncertainties and unknown disturbances. The PD controller is used in outer-loop so that the performance requirements of the motion control system are satisfied. While in DOB, the feedback of estimated disturbance in the inner-loop is used to obtain the robustness of the motion control.

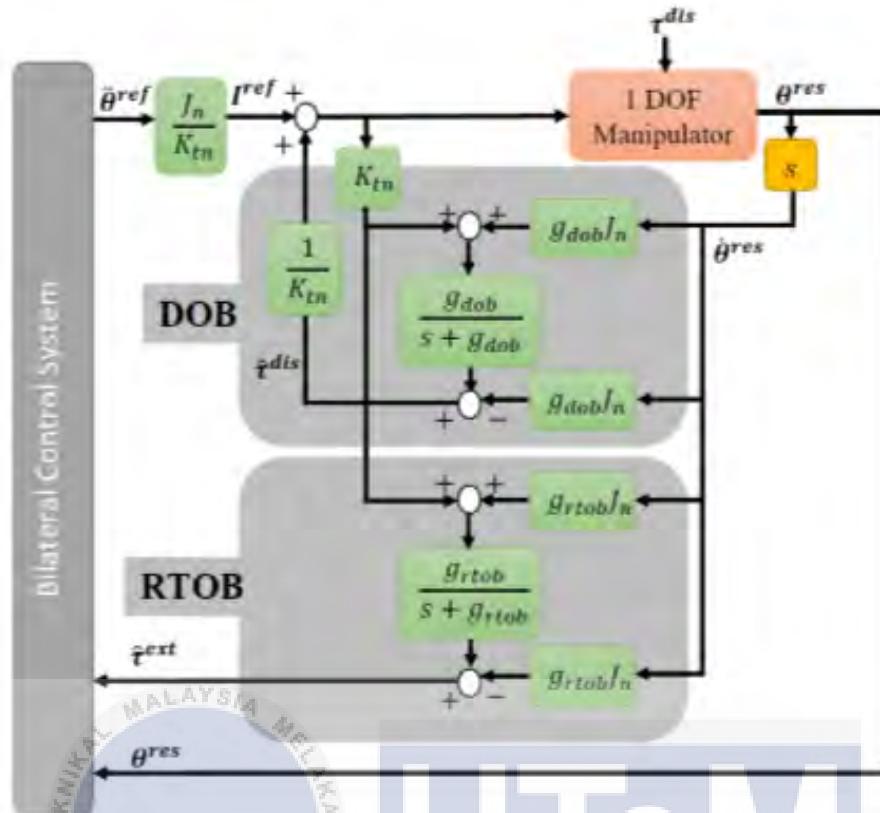

Figure 2.6: Block diagram of DOB and RTOB.

From Figure 2.6, F^{dis} is a total disturbance force. A total disturbance force consists of external force, internal force, coulomb friction and viscous force as shown in the Equation 2.1. A generalised motion of equation a manipulator is shown in Equation 2.2. Then F^{dis} can be arrange to an equation shown in Equation 2.3. In the real practical, it is hard to obtain an acceleration value from a sensor. However, an acceleration parameter can be obtained by differentiate the velocity. A differentiation cause a lot of noise to a system, hence a low-pass filter is need to be applied to reduce the noise in velocity signal. From that block diagram shown in Figure 2.6, the \hat{F}^{dis} can be transformed to an equation shown in Equation 2.4. In Equation 2.6, \ddot{x} is due to the differentiation from differentiator "s". And the final equation is shown in Equation 2.8 which shows that the disturbance observer is designed to estimate the disturbance force through a low-pass filter, where $\frac{g_{dis}}{s + g_{dis}}$ is a low-pass filter (LPF) and \hat{g}_{dis} is a cut-off frequency.

$$F^{dis} = F^{int} + F^{ext} + F^c + D\dot{\theta}^{res} - (M - M_n)\ddot{x}^{ref} \quad (2.1)$$

$$F = F^{ref} - F^{dis} \quad (2.2)$$

$$F^{dis} = F^{ref} - F \quad (2.3)$$

$$\hat{F}^{dis} = (F^{ref} + \dot{x}g_{dis}M_n)\left(\frac{g_{dis}}{s + g_{dis}}\right) - \dot{x}g_{dis}M_n \quad (2.4)$$

$$\hat{F}^{dis} = \frac{F^{ref}g_{dis} + \dot{x}g_{dis}^2M_n - \dot{x}g_{dis}M_n(s + g_{dis})}{s + g_{dis}} \quad (2.5)$$



$$\hat{F}^{dis} = \frac{F^{ref}g_{dis} - \dot{x}g_{dis}^2M_n}{s + g_{dis}} \quad (2.6)$$

$$\hat{F}^{dis} = \frac{g_{dis}}{s + g_{dis}} (F^{ref} - \ddot{x}m_n) \quad (2.7)$$

$$\hat{F}^{dis} = \frac{g_{dis}}{s + g_{dis}} F^{dis} \quad (2.8)$$

In addition, workspace observer(WOB) is a kind of DOB for motion control of multi-degree-of-freedom manipulator. The equivalent mass matrix is used in this control system to convert the acceleration reference into force or torque reference. The force reference and velocity response is then used to estimate the disturbance force from workspace. This in result will guarantee the robustness of workspace control[13]. In short, every control system have its pros and cons when applied to the master-slave telerobotic system. After the control system is applied, an analysis method is needed to analyse the performance and stability of the system to determine the result of the control system.

2.6 Analysis Method

Analysis method is needed to track the result of an experiment. It is used to track the bilateral master-slave telerobotics system's transparency and robust stability. There are few analysis methods used mentioned from [14].

Firstly, passivity-based methods are used for analysis of their coupled stability and in the same time for robust bilateral telerobotics controllers. Given by that environment, MSN, and operator are passive, the stability of telerobotics system can be guaranteed. However, the conservative of robust stability condition is rendered due to every network in coupled system needs the passivity requirement.

Compare to the two-port passivity criterion as shown in Figure 2.7, an analysis method developed is by using the structured singular value (SSV) or absolute stability of Llewellyns criterion. This method are used to guarantees the passivity of one-port network. This condition makes passive operator which is environment become coupled stability by terminate the MSN with passive environment which is operator. However, although this method have been improved than the previous one, it is still affected by assumed unbounded range of environment impedances and operator. This results the system become unrealistic.

According to the case, the effect on stability by operator and environment impedance become an open problem to be solved. Researchers Cho and Park implemented the minimum and maximum of the operator impedance and environment, while Adams and Hannaford used the same method but only applied on operator arm impedance. Hashtrudi-Zaad and Salcudean utilized maximum impedances as shunt impedances with the environment and operator with an unbounded range of impedances. The chances for flexibility in Llewellyns criterion is the approach stated in above which include operator impedances and bounded environment. Llewellyns criterion would not give direct and clear mean to check the environment and operator impedances if the coupled telerobotics system is unstable.

After that, a paper published by Edwards and Sinsky proposed the using of wave variables and scattering parameters to analysis the stability condition in microwave systems. Next, Orfanidis had further study the wave variables and scattering method and verified the

absolute stability graphically. Then, Amir Haddadi use this method to convert all the parameter including transmitted impedances, environment and operator to reflection coefficients. The purpose of this method is to solve the absolute stability and passivity issue in scattering domain. The size of environment region is maximised by extending the visual approach to 3D and the new stability parameter.

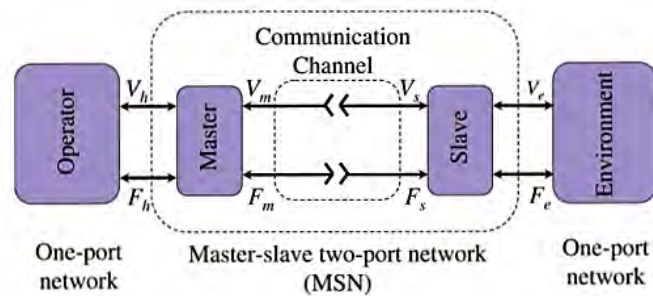

Figure 2.7: Architecture of telerobotics system which involved 5 basic elements. F denotes force and V denotes velocity. The subscripts h, e, m and s represent the operator, environment, master and slave respectively.

Lastly, Shafiq Islam employed Lyapunov-Krasovskii functions to align error of the slave and master robots and derive the stability and tracking properties of the position[3]. This method is used in the presence of regardless the symmetrical and unsymmetrical time-varying delays. Also, the situation is also need to be under constant force input between master manipulator and human and between slave manipulator and environment.

2.7 Summary

As a conclusion, this literature review has largely concentrated on theory and findings from the past researches that have been done. In short, this chapter has covered about the overview about the master-slave telerobotic system, requirements needed in this system, challenges in implementing the telerobotic system, and how researchers solve the problem with different kind of methods from past works, and finally the analysis method in testing the transparency and stability of system.

In the application of bilateral master-slave telerobotic manipulator system, the only information needed is position of master and slave manipulators. From the position information acquired from master system, it is then transmit to the slave system, and slave system

will follow every command of position information received from master system and vice versa. In this system, master and slave manipulators should be followed closely to each other if position controller has good capabilities in position tracking.

However, extend to the application of bilateral master-slave telerobotic manipulator system with fulfilling the haptic system, the system is required to be equipped with DOB and RTOB. The position of the system is controlled by DOB while the force of the system is controlled by RTOB. The system without using force sensor guarantee robustness of the system. While the system can automatically calculate and suppress the force disturbance and external force that is present in master and slave system. In a result by implement this system, human operator at master system can have tactile sensation of touch feeling of the environment from slave system even though human operator is not present in the environment area.

Time-delay is an unavoidable problem occurred in the bilateral telerobotic system due to the delay in data transmission between master and slave system. Many methods have been proposed by researchers such as wave variable, scattering approach, two-port networks, fuzzy logic and neural network adaptive control. All methods have its advantages and disadvantages in term of transparency and stability. Hence, the analysis method is also needed to verify those proposed method to examine the system in term of transparency and stability of the system. In simpler way of analysis method, the bilateral system's performance can be determined due to the accuracy of position of slave manipulator follow the master movement position and the time delay between them. Moreover, there is still do not have a bilateral master-slave telerobotic arm manipulator system applied on industrial robot such as KUKA youBot in Malaysia yet. Hence, it will be useful to develop the telerobotic system on industrial robot, study and analysis the time-delay and performance on the industrial robot's telerobotic system. For the next chapter, the methodology of this project will be discussed.

CHAPTER 3

RESEARCH METHODOLOGY

3.1 Overview

In this chapter, there are three steps to be implemented and discussed. In order to achieve the final objective of this project, every parts have to be conducted step-by-step. The sequence of this research is presented in flow chart as shown in Figure 3.1. Each of the following parts will be clearly discussed and how the steps is carried out clearly.

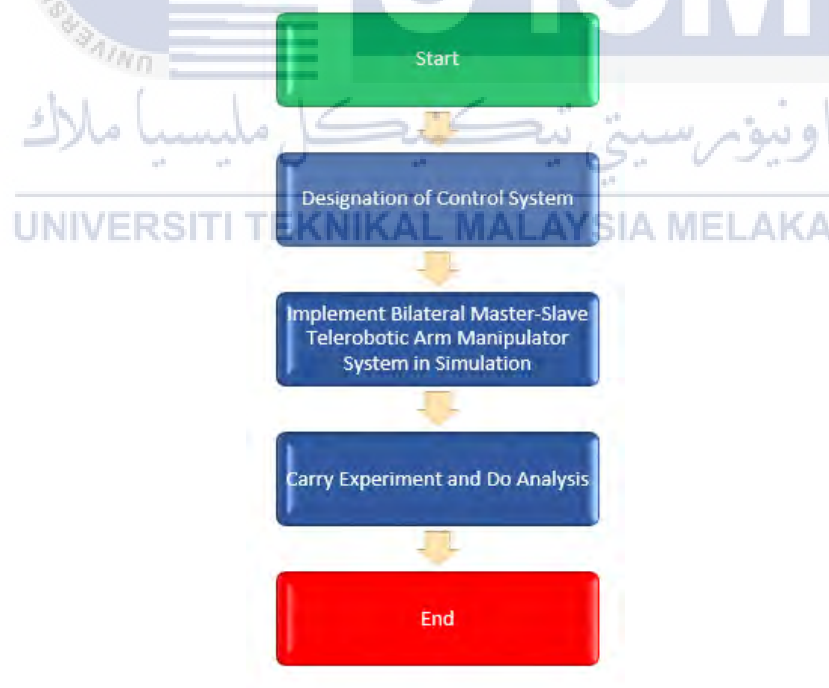

Figure 3.1: Flow Chart of the Research

3.2 Designation of Control System

A control system designation is utmost important for a precise motion control. In bilateral control, the accuracy of motion between master and slave robot is emphasised, hence a good control system is a must in this project. For this project, several control system are designed in order to do comparison and analysis to identify which controller has the best performance for bilateral master-slave telerobotic arm manipulator system. There will be 3 types of control system which are P control, PD control, and PID control. But first, before involving a controller, a block diagram of a single link motor control system without any controller is needed as shown in Figure 3.2.

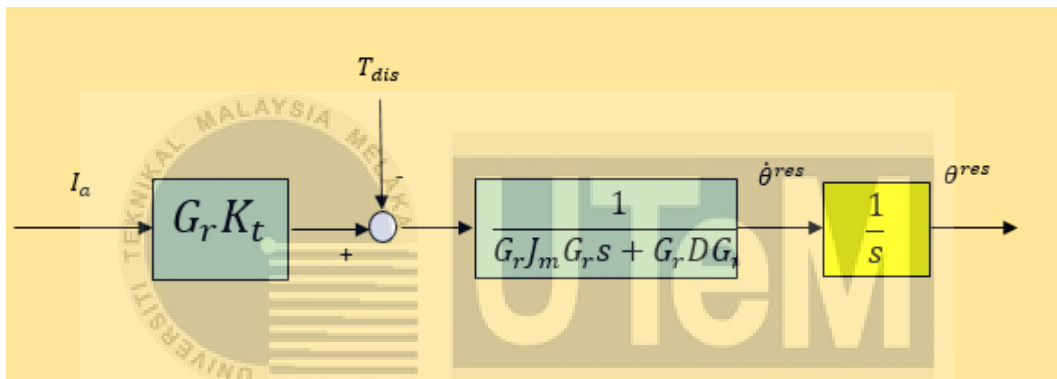

Figure 3.2: Block diagram of Motor.

where;

θ^{res} [rad] : Motor rotation angle.

I_a [A] : Torque electric current.

T_{dis} [Nm] : Motor torque.

G_r : Gear ratio.

K_t [Nm/A] : Torque constant.

J_m [kgm²] : Inertia of the motor shaft.

D [Nmrad/s] : Viscous friction factor.

After that, a P controller is added as shown in the block diagram in Figure 3.3. In the P control which consist of one important variable, which is proportional term, K_p . As shown in the block diagram, the input of K_p is the difference between the input angle and

output angle of the system. The main purpose of proportional term is used to reduce the rise time of the system which give system a quick respond, and reduce the steady-state error. In a system, the shorter the rise time and settling time, the better the performance of a system. The smaller the overshoot, system is more stable. In short, the final aim of using a P controller is to help the system in achieving desired response which is critical damping. A system equipped with P controller will certainly better than a system without P controller in term of settling time, overshoot and steady-state error. P controller is chosen is because because it is simple in tuning the gain.

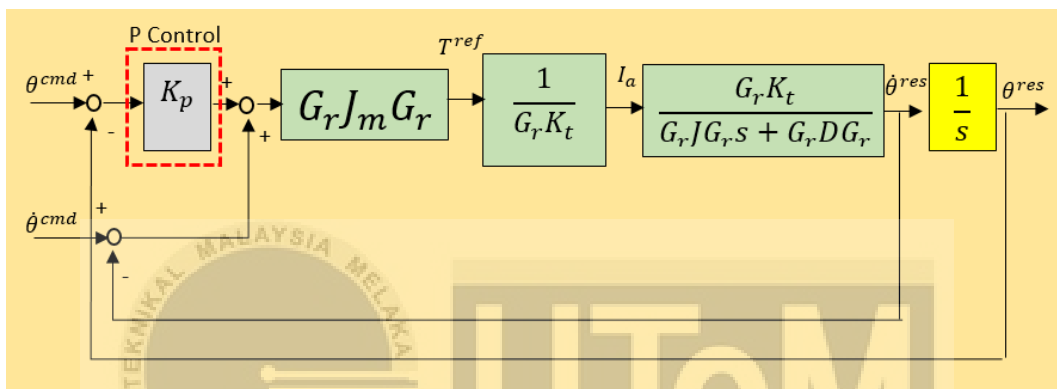

Figure 3.3: Block diagram adding P control to the manipulator system.

where;

θ^{res} [rad] : Respond angle of motor rotation.

θ^{cmd} [rad] : Command angle of motor rotation.

I_a [A] : Torque electric current.

T^{ref} [Nm] : Motor torque.

G_r : Gear ratio.

K_t [Nm/A] : Torque constant.

J_m [kgm²] : Inertia of the motor shaft.

D [Nmrad/s] : Viscous friction factor.

K_p : Proportional Gain in P controller.

After the P controller is designed, a derivative term, K_d is added into the P control system to become second design of control system, which is PD control system. A PD control system block diagram is shown in Figure 3.4. In the P control system, K_p is multiplied

by difference of input angle and output angle. However in PD control system, K_d is multiplied by difference between the rate of change of output angle and the rate of change of input angle. The derivative term, K_d is used to help reducing the settling time, eliminate the overshoot problem, and improve the stability of the system. Every system has different requirement performance, hence it do not mean that PD control system is better than P control system. For the last section of this chapter, an experiment will be carried out to compare the performance of these two control systems impact on the bilateral master-slave telerobotic arm manipulator system.

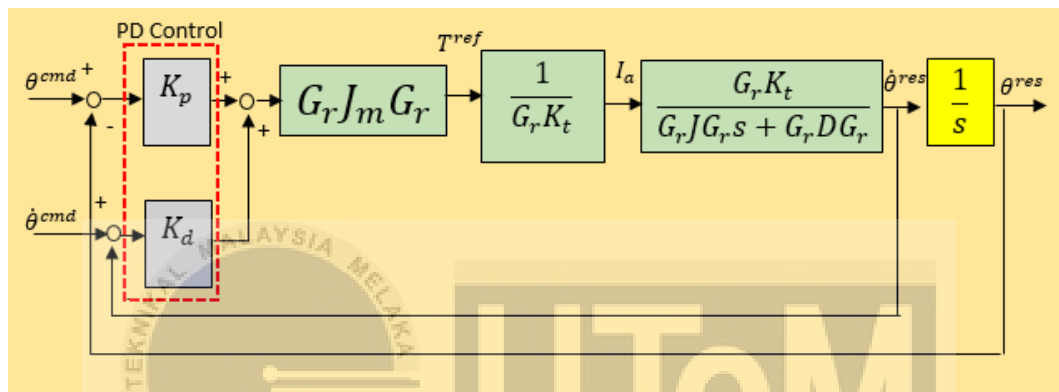

Figure 3.4: Block diagram adding PD control to the manipulator system.

where;

θ^{res} [rad] : Respond angle of motor rotation.

θ^{cmd} [rad] : Command angle of motor rotation.

I_a [A] : Torque electric current.

T^{ref} [Nm] : Motor torque.

G_r : Gear ratio.

K_t [Nm/A] : Torque constant.

J_m [kgm²] : Inertia of the motor shaft.

D [Nmrad/s] : Viscous friction factor.

K_p : Proportional Gain in PD controller.

K_d : Derivative Gain in PD controller.

After PD control system is designed, the third design control system is further improved with adding another term, which is integral term, K_i into the PD control system. This

results in forming a new design of control system, which is PID control system as shown in 3.5. The integral term, K_i is used to reduce until it eliminate the steady-state error. However, the zero steady-state error is for an ideal situation, at the most cases a system still exist some error due to the external disturbance from environment. The analysis will be done through simulation to get the result.

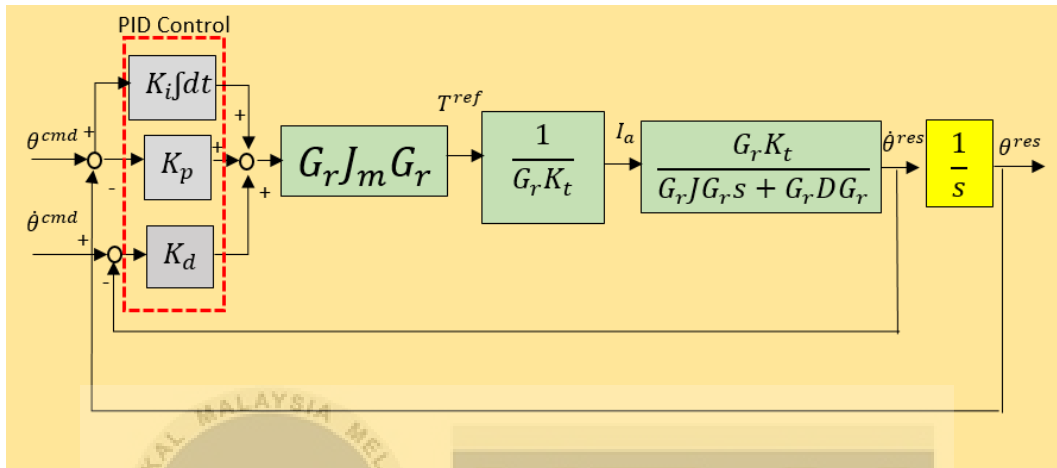

Figure 3.5: Block diagram adding PID control to the manipulator system.

where;

θ^{res} [rad] : Respond angle of motor rotation.

θ^{cmd} [rad] : Command angle of motor rotation.

I_a [A] : Torque electric current.

T^{ref} [Nm] : Motor torque.

G_r : Gear ratio.

K_t [Nm/A] : Torque constant.

J_m [kgm²] : Inertia of the motor shaft.

D [Nmrad/s] : Viscous friction factor.

K_p : Proportional Gain in PID controller.

K_d : Derivative Gain in PID controller.

K_i : Integral Gain in PID controller.

3.3 Implementation of Bilateral Master-Slave Telerobotic Arm Manipulator System in Simulation

To verify the designed control systems, a simulation have to be done to prove the designed control system is robust. There are two kind of software that can be used to simulate KUKA youBot which are V-REP and Gazebo. In this project, V-rep is used due to its popularity and there has more source can be found through online. Inside the V-REP, it already have built in KUKA youBot under mobile robot section, which included all the necessary parameter such as weight and size of the robot. Before we started to do the simulation, there is a few settings have to be done in the V-REP scene object properties in order to make KUKA youBot moving. Firstly, the joint of KUKA youBot have to change to "torque/force mode". Secondly, in the joint dynamic properties, untick the "control loop enabled", and tick "motor enabled" and "lock motor when target velocity is zero". This setting is shown in Figure 3.6 and Figure 3.7.

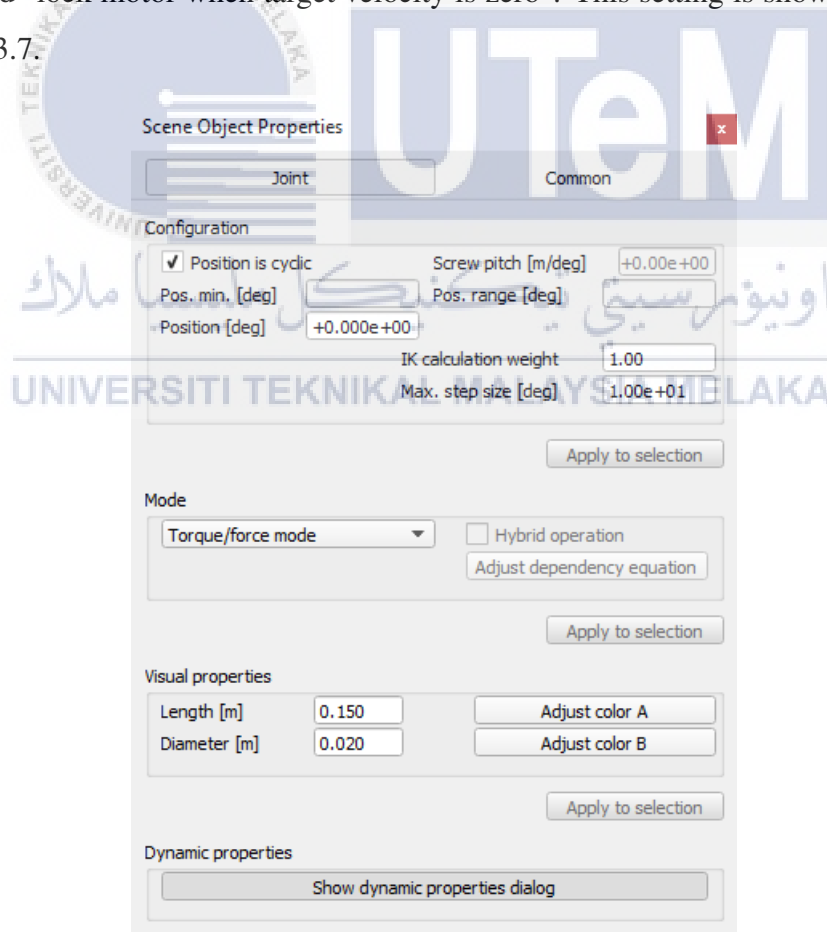

Figure 3.6: Scene object properties of KUKA youBot joint setting in V-REP.

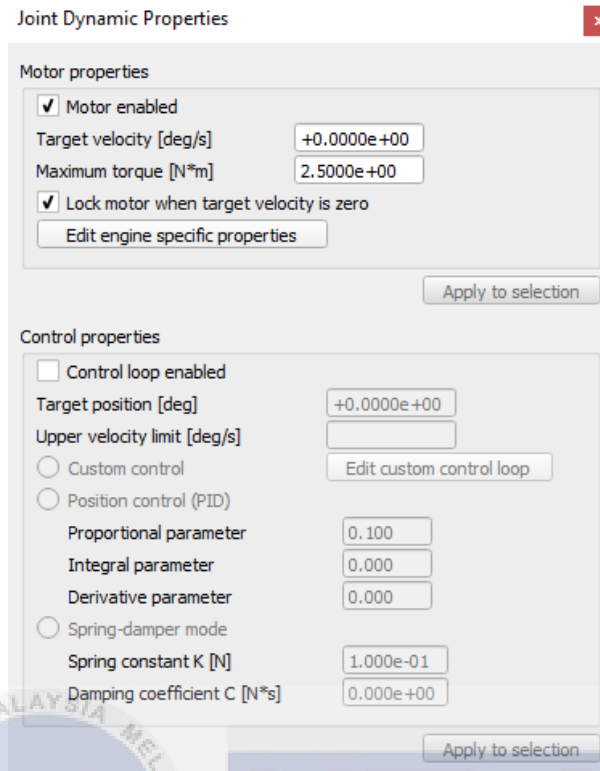

Figure 3.7: Joint dynamic properties of KUKA youBot joint setting in V-REP.

In the coding part, there are many software that can be chosen to apply control system into bilateral telerobotic system. There are two choice, first is used the LUA language inside the V-REP itself, the second choice is to use remote API to connect to V-REP software. In remote API, other programming languages such as c/c++, Java, Matlab, Octave, Urbi and Python can be used. In this project, remote API function with Python language is used because of it's easiness to use and more functions can be used. To enable the using of remote API function, there has a setting need to be done which is disable the non-threaded child scripts of KUKA youBot in V-REP as shown in Figure 3.8. Then a cuboid is created in V-REP scene, a threaded child script is created and it is inserted into the cuboid to create a communication channel to another programming software. In the programming code, the code shown in Figure 3.9 has to be inserted in threaded script created in V-REP while the code shown in Figure 3.10 has to be inserted in Python to create a communication channel between python software and V-REP software.

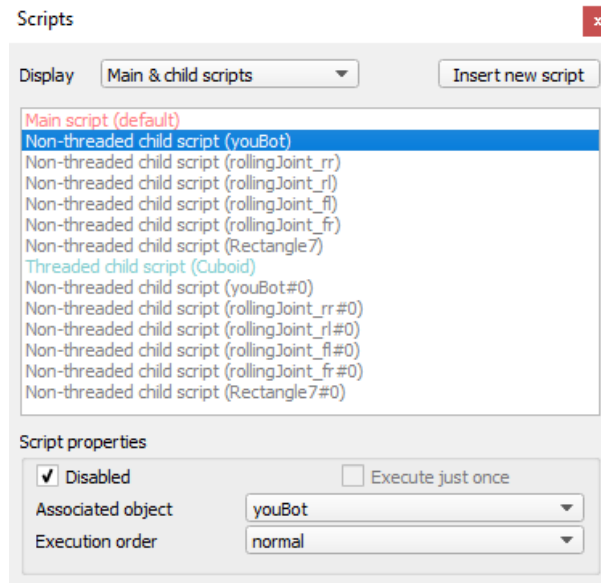

Figure 3.8: Scripts setting of KUKA youBot in V-REP.



Figure 3.9: Programming code in threaded child script of V-REP .



Figure 3.10: Programming code in Python.

Simulation have to be approached step by step. After the settings of V-REP is set and the communication channel have been created between V-REP and remote API, it is time to move the a KUKA youBot arm without any controller as shown in Figure 3.11 to verify all the settings and communication is success. Otherwise, troubleshoot until KUKA youBot can be moved.

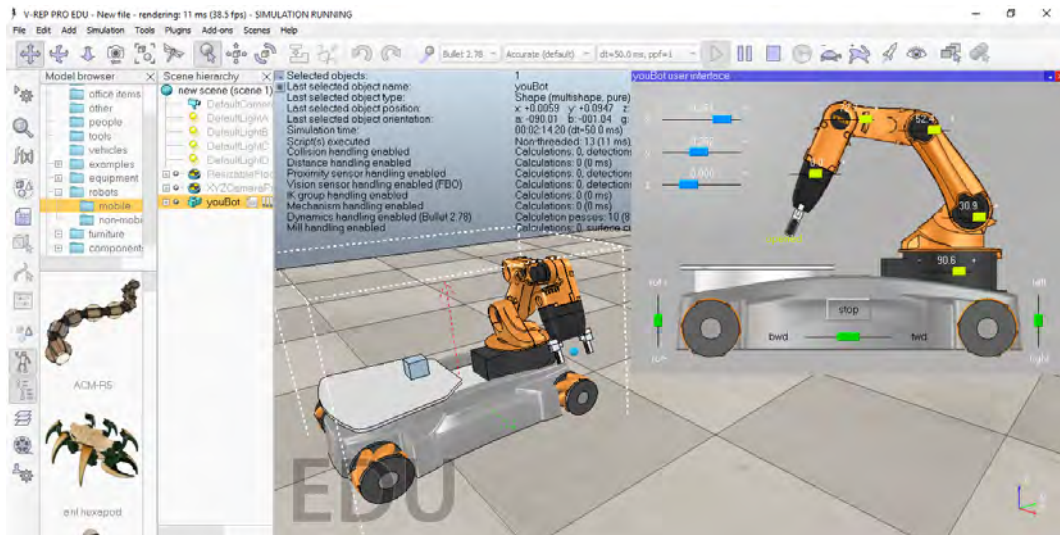

Figure 3.11: Simulation of single KUKA youBot with command robot to rotate 90 degree.

In the next step, two KUKA youBot are used to simulate in V-REP for the development of bilateral master-slave telerobotic arm manipulator system as shown in Figure 3.13. A complete block diagram is designed as shown in Figure 3.12. Implement the complete block diagram to the V-REP and run the simulation on V-REP. Move the link 1 of master robot arm to 90 degree, and observe the motion of slave robot. The desired result is the slave robot will track the movement of master robot accurately. Then put an obstacle as shown in Figure 3.14 such as an cylinder drawn in V-rep, which is used to block the way of link 1 of robotic arm while rotating 90 degree. Run the simulation, observe the result and extract the data as obtained result. The desired result is that when the slave robot is blocked by the obstacle and stop, the master robot arm will stop at the same position even though there is no obstacle blocking master robot arm.

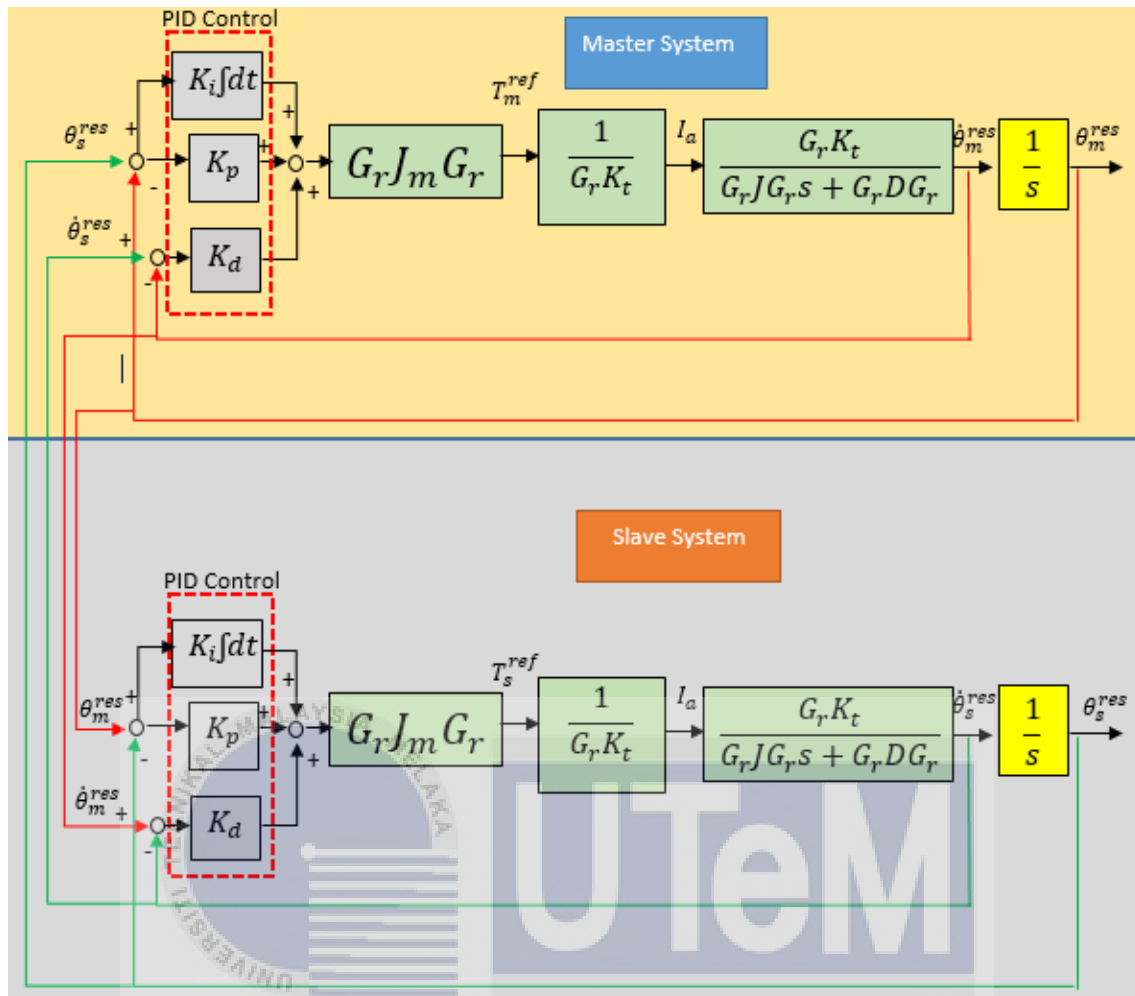

Figure 3.12: Block diagram of bilateral telerobotic arm manipulator.

UNIVERSITI TEKNIKAL MALAYSIA MELAKA

where;

T_m^{ref} [Nm] : Master motor torque.

T_s^{ref} [Nm] : Slave motor torque.

θ_m^{res} [rad] : Respond angle of master manipulator.

θ_s^{res} [rad] : Respond angle of slave manipulator.

J_m [kgm²] : Moment of inertia of motor shaft.

K_m [Nm] : Torque constant.

I_a [A] : Torque electric current.

G_r : Gear ratio.

K_p : Proportional Gain in PID controller.

K_d : Derivative Gain in PID controller.

K_i : Integral Gain in PID controller.

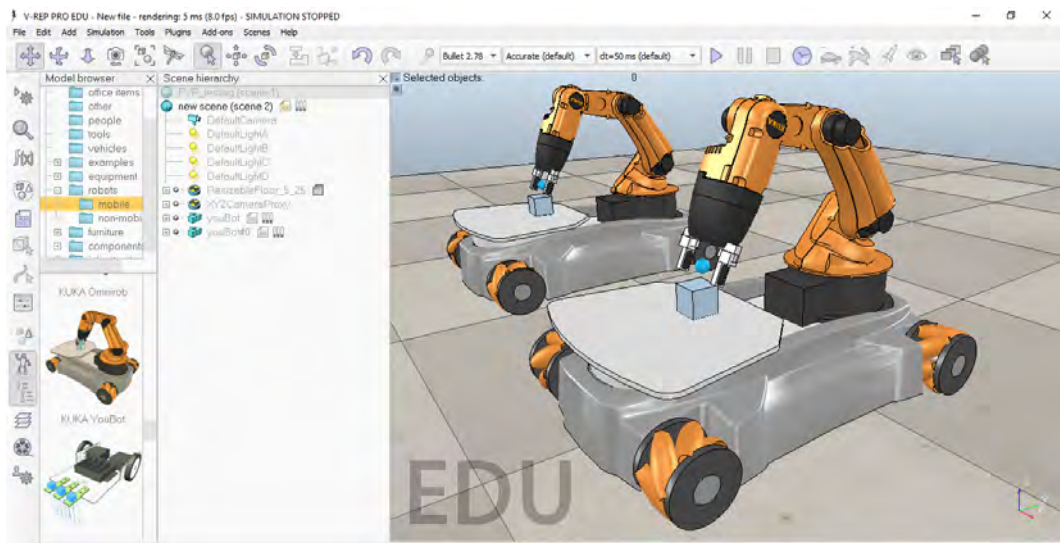

Figure 3.13: Simulation of two KUKA youBot with command master robot to rotate 90 degree.

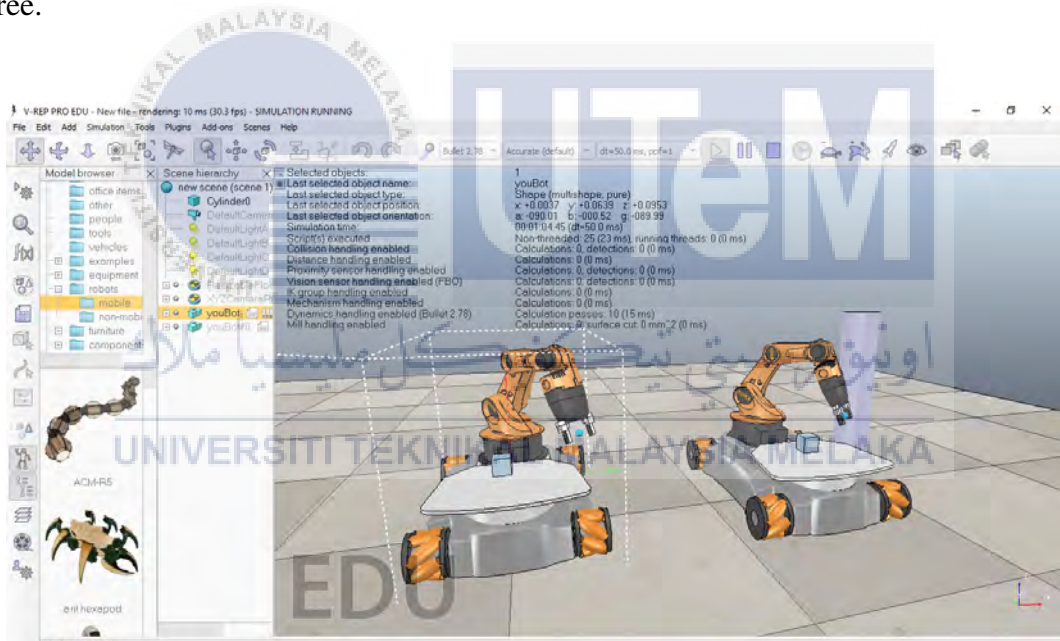

Figure 3.14: Simulation of two KUKA youBot (master robot at left and slave robot at right) with a cylinder is placed to block the slave robot.

In fact, the block diagram from Figure 3.12 is similar to the previous single PID control system, the difference is there are two exactly same block diagram applied to each master and slave robot arm. Moreover, the position and force output is linked to each other too. To implement the bilateral telerobotic system or transfer information in haptic communication, position tracking and law of action and reaction between master and slave system are vital. From the diagram, the τ_M represents the torque of master manipulator provided by human

operator, whereas τ_s represents the torque of slave manipulator applied by environment.

To implement the bilateral teleoperation, it must obey two rules, which are the common mode and differential mode. The equation of common mode is shown in Equation 3.1, and the rule to be followed is in Equation 3.3, which state that the summation of external torque from master and slave system must always be zero. The common mode is controlled by force or torque. On the other side, the differential mode is controlled by position. The equation of differential mode is shown in Equation 3.2, and the law to be obeyed is in Equation 3.4, which mentioned that the subtraction of position from master and slave must be zero.

$$\tau_{\text{com}}^{\text{res}} = \hat{\tau}_M^{\text{ext}} + \hat{\tau}_S^{\text{ext}} \quad (3.1)$$

$$\theta_{\text{diff}}^{\text{res}} = \theta_M^{\text{res}} - \theta_S^{\text{res}} \quad (3.2)$$

$$\tau_{\text{com}}^{\text{res}} = 0 \quad (3.3)$$

$$\theta_{\text{diff}}^{\text{res}} = 0 \quad (3.4)$$

Hence from the equations and rules provided, an equation of motion is formed. General equation of bilateral master-slave telerobotic system is shown in Equation 3.5.

$$\ddot{\theta} = K_p(\theta^{\text{cmd}} - \theta^{\text{res}}) - K_d(\dot{\theta}^{\text{cmd}} - \dot{\theta}^{\text{res}}) \quad (3.5)$$

From the general equation, the equation of motion in master and slave system are Equation 3.6 and Equation 3.7 respectively.

$$\ddot{\theta}_M = K_p(\theta_S - \theta_M) - K_d(\dot{\theta}_S - \dot{\theta}_M) \quad (3.6)$$

$$\ddot{\theta}_S = K_p(\theta_M - \theta_S) - K_d(\dot{\theta}_M - \dot{\theta}_S) \quad (3.7)$$

3.4 Experiment and Analysis

After the second objective have been implemented and achieved, the third objective has to be achieved by carrying out an experiment. The purpose of doing this experiment is first to prove the common mode and differential mode of bilateral master-slave telerobotic arm manipulator system, and the second is to observe the effect of different control systems to the bilateral master-slave telerobotic manipulator system and compare between them. Normally if the telerobotic system is built with self created robot, researchers will insert encoders or other force sensors to the motor of joints to collect the data of the movement or force value. However, several sensors are originally installed in the KUKA youBot which could provide joint parameter and collected from V-REP software. From the V-REP software, an external arm as shown in Figure 3.15 is created and act as an extra force to be exerted to the KUKA youBot arm in the experiment later. To prove the bilateral master-slave telerobotic arm manipulator system, common mode and differential mode have to be achieved. Hence the experiment can be divided into two parts, part one is to prove the common mode, while part two is to prove differential mode.

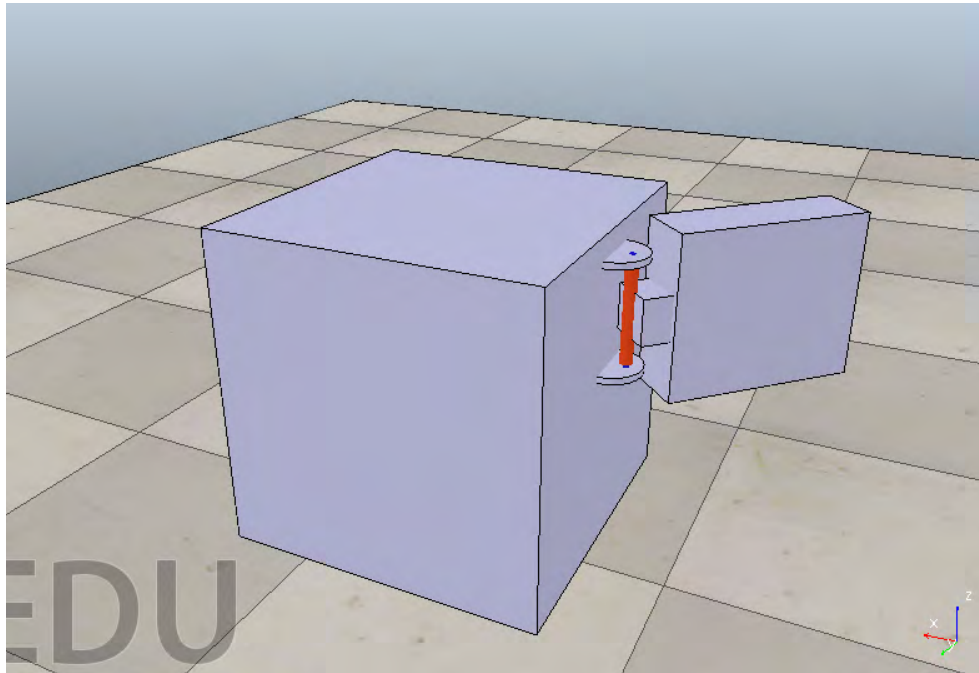

Figure 3.15: An external arm is created by using V-REP software to act as external force.

In common mode, the summation of external torque from master and slave system must always be zero. Hence in the part one experiment, different maximum torque of KUKA youBot joint 1 is set to show different results in order to prove the common mode is achieved. Meanwhile, the maximum torque of created external arm is adjusted to a suitable torque that will makes the KUKA youBot arm to exert its maximum torque while in the same time master youBot arm would not be moved when slave youBot arm is being blocked. This is because when the torque of extra arm is too large and move the master KUKA youBot arm, the master KUKA youBot arm unable to reach its maximum torque when the youBot arm is moving, and hence cannot get the desired result. In this experiment, P controller is used in the system, the proportional term, K_p is set to 1. When the simulation starts, the external arm will swing its arm and hit master KUKA youBot arm, and it is expected that the slave youBot arm will follow the motion of master youBot until it is being blocked by an obstacle. This will cause slave youBot arm having maximum reaction force against the obstacle. When slave KUKA youBot arm is being blocked by an obstacle, the master KUKA youBot arm will follow the slave motion. The data is extracted by reading both two master and slave of KUKA youBot joint 1 force, and the result is plotted in a graph. The experiment is set up as shown in Figure 3.16 and it is carried out three times with different maximum torque of external arm and KUKA youBot joint 1 arm as shown in Table 3.1.

Table 3.1: Maximum torque of external arm and KUKA youBot arm

External Arm Maximum Torque(Nm)	youBot Maximum Torque(Nm)
10	5
35	15
55	25

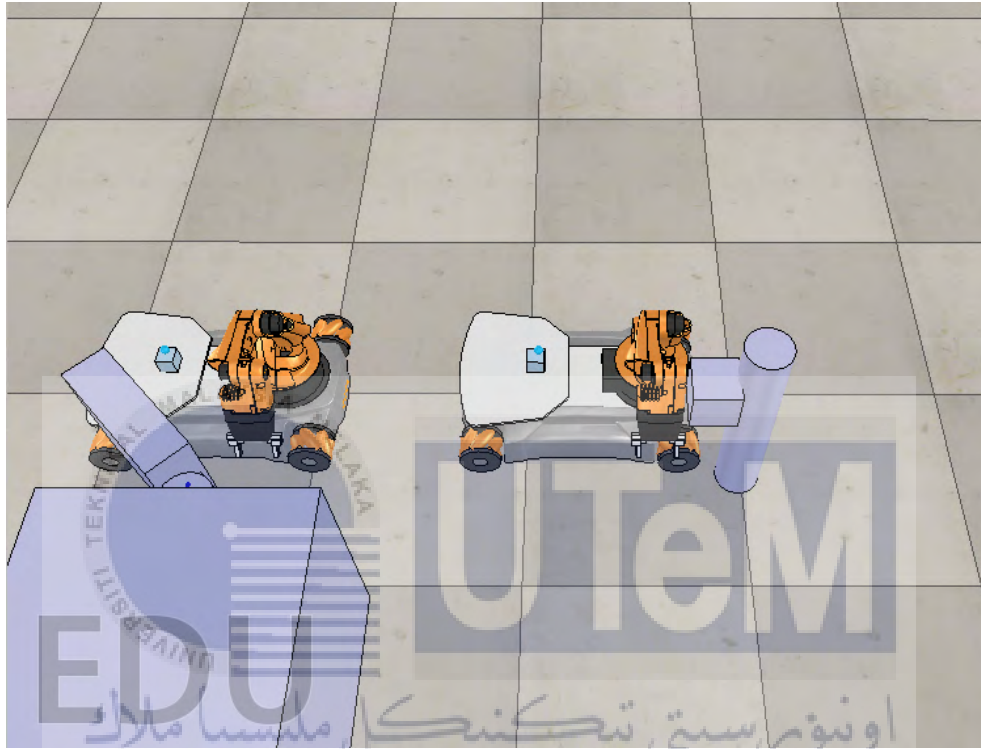

Figure 3.16: An obstacle is used to block the way of slave youBot arm when it is moving.

After proved the common mode, next the experiment to prove differential mode is designed. In differential mode, the subtraction of position from master and slave must be zero. Hence, in part two experiment, different angle or position between the master youBot arm and slave youBot arm is emphasised. In this experiment, the fixed variable will be the maximum torque of KUKA youBot arm, which will fix the maximum torque of KUKA youBot arm to 5Nm and the external arm to 35Nm. and the manipulated variable will be the the paramater value of proportional term, K_p , derivative term, K_d , and integral term, K_i . Experiment will be divided into three section by using three different control system which is P controller, PD controller, and PID controller. When the simulation starts, the external arm will swing and exerted force on master youBot. In expected result, the slave youBot should follow the motion of master youBot. The angle of the master youBot arm and slave youBot

arm is extracted and plotted in graph. The result is recorded and do analysis to identify the best controller and determine the most suitable parameter value of proportional term, K_p , derivative term, K_d , and integral term, K_i . The experiments are set up as shown in 3.17



Figure 3.17: Master and slave is moved without any obstacle.

In experiment using P controller, the experiments are carried out 6 times with different values of proportional term, K_p as shown in Table 3.2.

Table 3.2: Different value of proportional term, K_p

Value of proportional term, K_p
1
5
8
10
20
50

Similar as experiment above, for PD controller, the experiments are carried out 6

times with different values of proportional term, K_p and derivative term, K_d as shown in Table 3.3. The value of proportional term, K_p is same as last experiment, while the derivative term, K_d is adjusted into the most stable and best performance for the system with experimental tuning.

Table 3.3: Different value of proportional term, K_p and derivative term, K_d

Value of proportional term, K_p	Value of derivative term, K_d
1	0.80
5	0.10
8	0.50
10	0.20
20	1.60
50	4.65

On the other hand, for PID controller, the value of proportional term, K_p and derivative term, K_d will be same as previous PD experiment. The integral term, K_i is added and adjusted to the most stable system by experimental tuning. The experiments are carried out 6 times with different values of proportional term, K_p , derivative term, K_d , and integral term, K_i as shown in Table 3.4.

Table 3.4: Different value of proportional term, K_p , derivative term, K_d , and integral term, K_i

Value of proportional term, K_p	Value of derivative term, K_d	Value of integral term, K_i
1	0.80	0.0100
5	0.10	0.0010
8	0.50	0.0050
10	0.20	0.0005
20	1.60	0.0050
50	4.65	0.0500

After collected all the data and graph is plotted, do analysis and discuss about the accuracy and time-delay between the master and slave robot. Also, an analysis about the precision of youBot arm to the reference angle and the settling time will be done. At the end, discuss which is the best controller to be used in this system and what is the best parameter value for proportional term, K_p , derivative term, K_d , and integral term, K_i . Settling time of the system do not need a calculation formula, instead, it can be observed from the plotted graphs. The accuracy of the movement between the master and slave robot, time delay of the movement between the master and slave robot and precision of final angle to the reference angle could be calculated by using the following formula in Equation 3.8, 3.9 and 3.10:

$$Accuracy = \left[1 - \frac{(y_m - x_m) - (y_s - x_s)}{(y_m - x_m)} \right] * 100\% \quad (3.8)$$

where;

x_m = Initial angle for master robot

x_s = Initial angle for slave robot

y_m = Final angle for master robot

y_s = Final angle for slave robot

The time-delay between master and slave robot can be calculated by using the following formula:

$$Timedelay = (t_{fm} - t_{im}) - (t_{fs} - t_{is}) \quad (3.9)$$

where;

t_{im} = Initial time taken for master robot

t_{is} = Initial time taken for slave robot

t_{fm} = Time taken for master robot to reach 2 rad

t_{fs} = Time taken for slave robot to reach 2 rad

$$Precision = \left[1 - \frac{\theta_{ref} - \theta_f}{\theta_{ref}} \right] * 100\% \quad (3.10)$$

where;

θ_{ref} = Reference angle of robot

θ_f = Final angle for robot

3.5 Summary

In short, the research methodology of this project have covered the the flow chart for overall implementation of this telerobotic system, the designation of different control system for the bilateral telerobotic system, the implementation of bilateral master-slave telerobotic arm manipulator system in software simulation. At the final stage, the way of experiment is set up and steps to carry out experiments, and the way to verify the common mode and differential mode of bilateral telerobotic system, the performance of this telerobotic system in term of accuracy and time-delay. In the next chapter, it will present the result from experiment and discuss about the analysis from the data obtained.

CHAPTER 4

RESULT AND DISCUSSION

4.1 Overview

In this topic, it will discuss about the result from simulation of development in bilateral master slave telerobotic arm manipulator system which divide into two parts, first part is the result for common mode verification and the second part is the result from the experiment to prove for differential mode. In the second part experiments, experiment is repeated by using different control system which is P control system, PD control system, and PID control system. The result is presented by using graph and discussion about the result is done.

4.2 Part 1: Result for Common Mode Verification

In the first part experiment, its purpose is to prove the bilateral master-slave telerobotic arm manipulator system has achieved the common mode which obey the Equation 3.3 explained in Chapter 3. When the experiment start, an external arm is swing and push the master KUKA youBot arm to move, slave KUKA youBot arm follows the motion of master until it is blocked by an obstacle. This results master youBot arm follow the motion of slave youBot arm. The force of both armed is recorded and plotted in a graph. The experiment is carried out three times with different maximum torque set to KUKA youBot arm.



Figure 4.1: Force data from master and slave arm with the maximum torque of 5N.

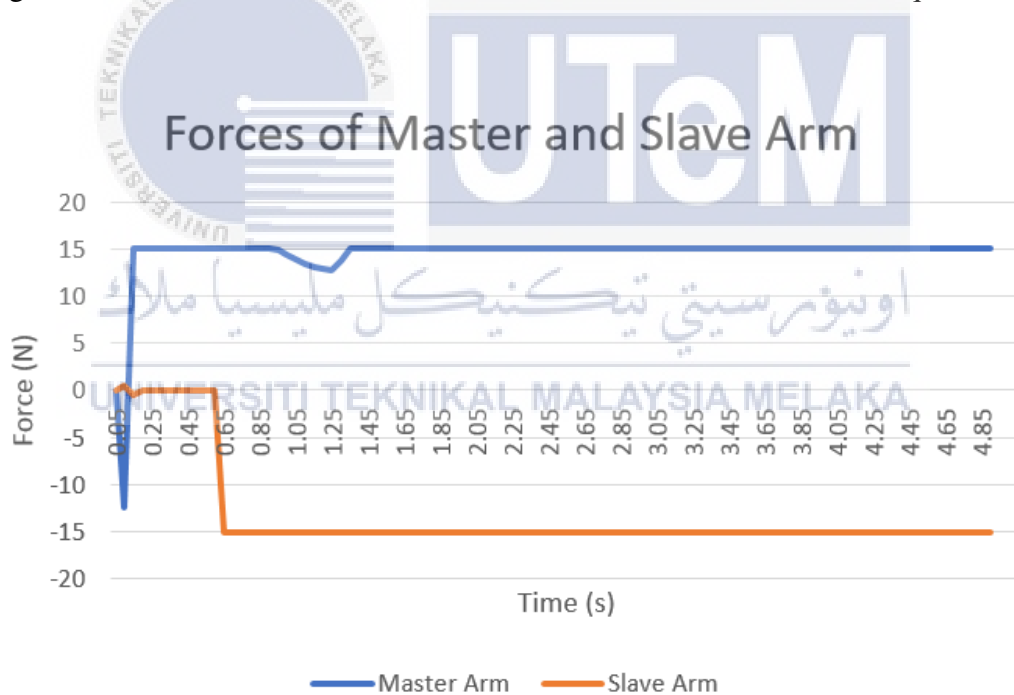

Figure 4.2: Force data from master and slave arm with the maximum torque of 15N.

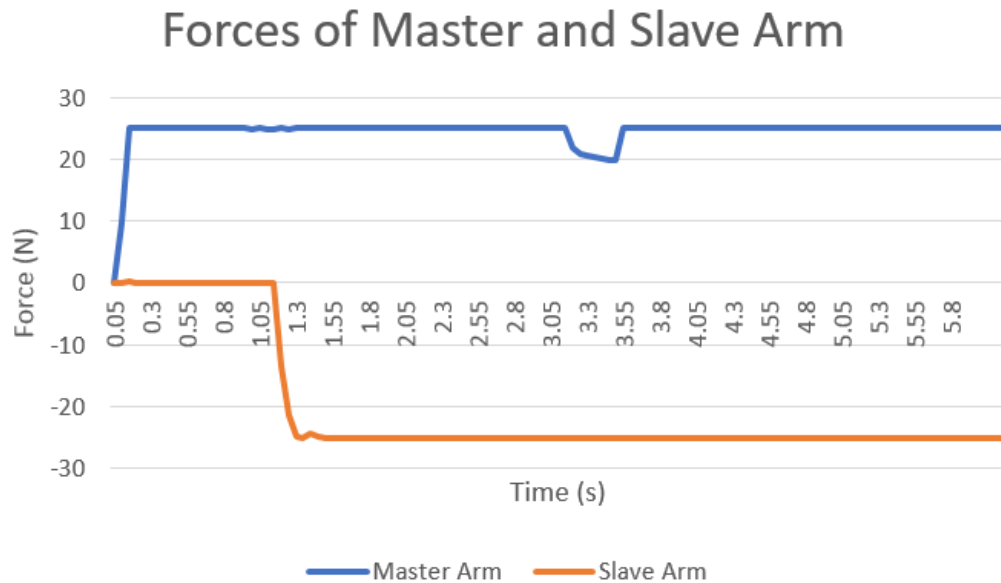

Figure 4.3: Force data from master and slave arm with the maximum torque of 25N.

Referring to Figure 4.1, it shows that time before 0.65s, the force of slave youBot arm is zero, this is because the slave arm is in free contact from any obstacle. However, once it is being blocked by an obstacle, it immediately has a reaction force against the obstacle. The graph shows that master youBot arm has giving its maximum torque of 5N while slave youBot arm has giving its maximum torque of -5N in the experiment. This proved that this bilateral master-slave telerobotic manipulator arm system has achieved the common mode and obey the Equation 3.3. To prove the validity of the result, the experiment is repeated with different maximum torque set to both master and slave youBot arm and the result is shown in Figure 4.2 and Figure 4.3. The results are almost same as Figure 4.1, the only different from the repeated experiments is both of the youBot arm giving different force value, but obey Equation 3.3 either.

In short, the experiment is success, and the designed bilateral master-slave telerobotic arm manipulator system has achieved the first requirement, which is the common mode.

4.3 Part 2: Result for Differential Mode Verification and Performance between different Controllers

In the second part experiment, the purpose is to prove the bilateral master-slave telerobotic arm manipulator system has achieved the differential mode which obey the Equation 3.4 explained in Chapter 3. Same as the previous experiments, an external arm is swing and push the master KUKA youBot arm to move, slave KUKA youBot arm follows the motion of master. But this time, there is no obstacle is used to block the way of slave youBot arm moving because the force is not being emphasised in the differential mode. Instead, the position or the angle is being focused to track the difference between the master youBot arm and slave youBot arm. Moreover, the experiment is divided into three sections which is using three different controller that are P controller, PD controller, and PID controller. To identify whether the angle of youBot arm rotate to the expected angle, a reference angle is needed. It is taken by fixing the external arm's maximum torque to 30Nm, it is used to move a youBot arm without any controller and without bilateral system. The free motion of youBot angle rotated after hitted by external arm is taken as reference angle. After the experiment, the reference angle is 3.27 rad and it is used to examine the performance of bilateral master-slave telerobotic arm manipulator system. The angle of both master and slave arm is being tracked, recorded and plotted in a graph for analysis.

In section one in which P controller is used, the experiment is repeated by using different value of proportional term, K_p . The experiment's result of using P controller is presented in Figure 4.4 to Figure 4.9. The step-input blue colour line is the reference angle which is 3.27 rad, while orange line is angle of master youBot arm rotation from original position and grey line is angle of slave youBot arm.

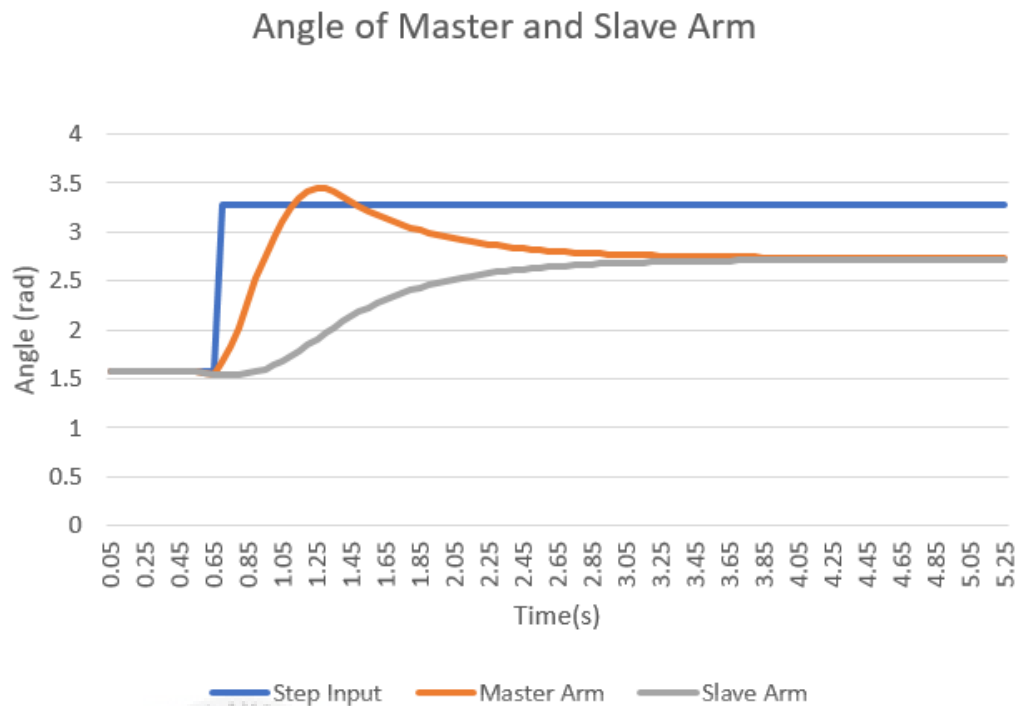

Figure 4.4: Angle of from master and slave arm rotated from its original position with value of $K_p=1$.

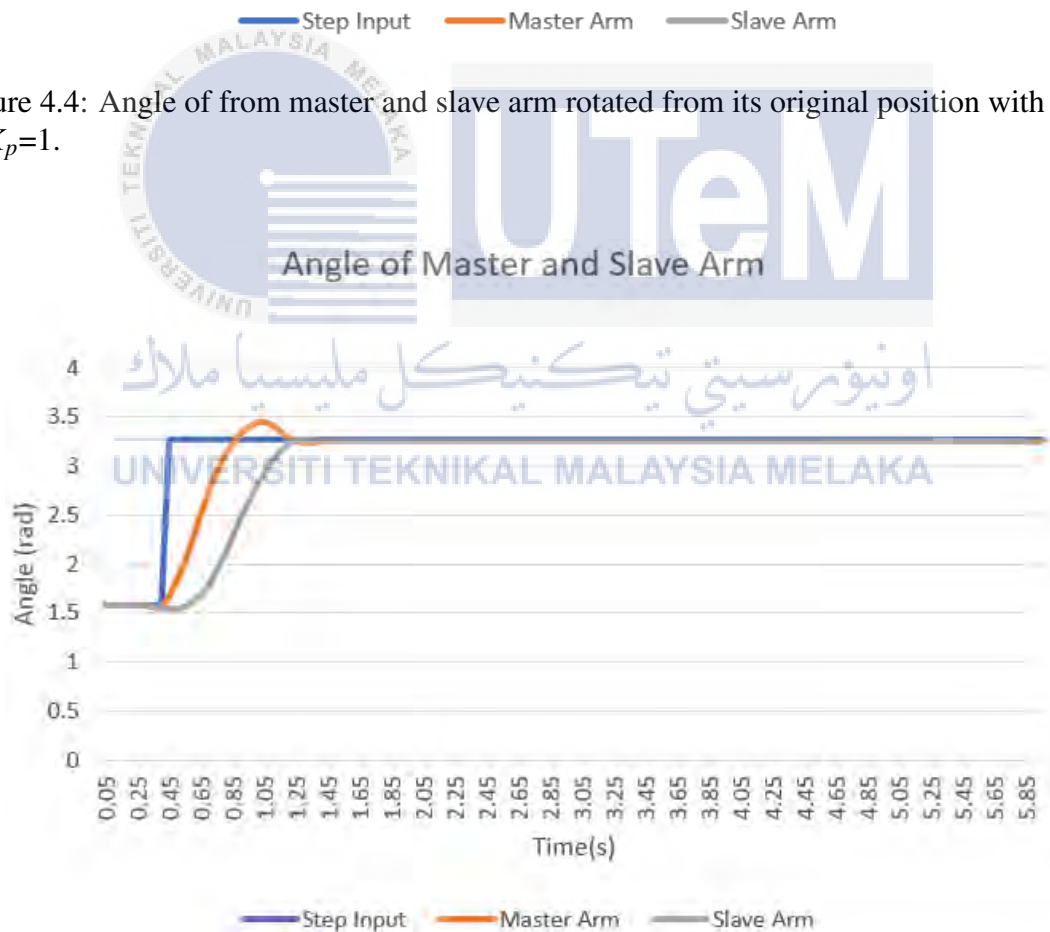

Figure 4.5: Angle of from master and slave arm rotated from its original position with value of $K_p=5$.

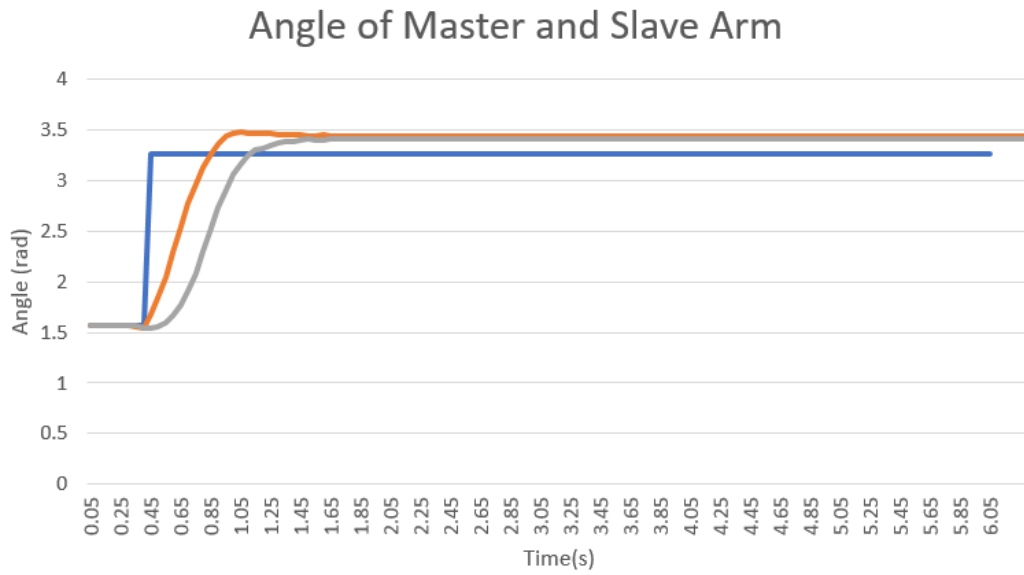

Figure 4.6: Angle of from master and slave arm rotated from its original position with value of $K_p=8$.

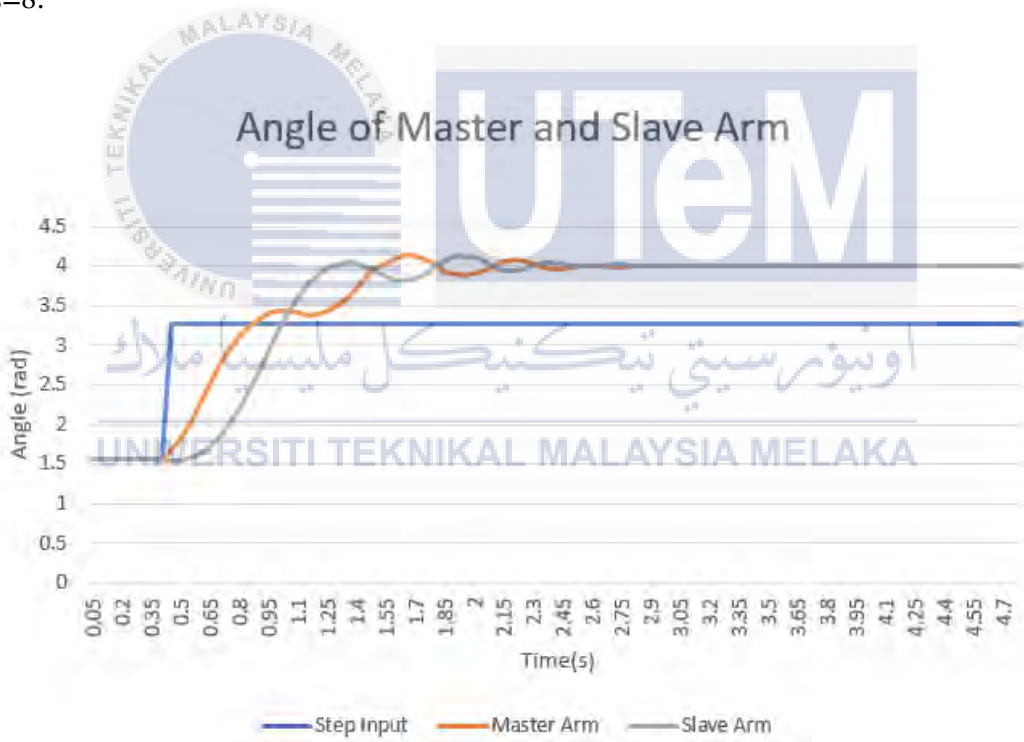

Figure 4.7: Angle of from master and slave arm rotated from its original position with value of $K_p=10$.



Figure 4.8: Angle of from master and slave arm rotated from its original position with value of $K_p=20$.

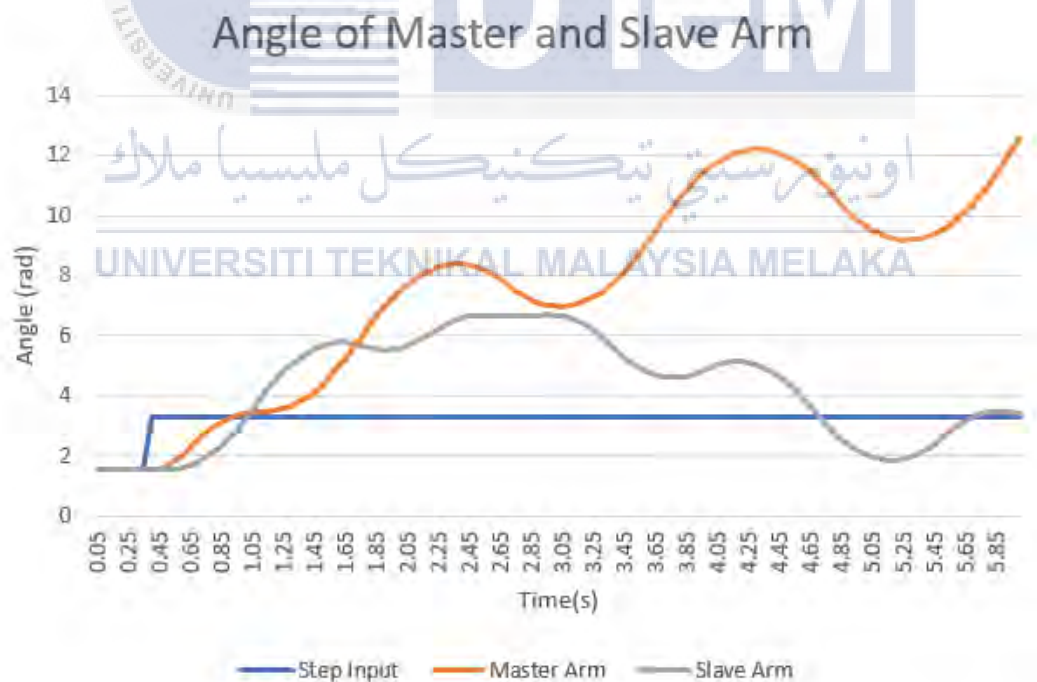

Figure 4.9: Angle of from master and slave arm rotated from its original position with value of $K_p=50$.

According to the six plotted graph, it can see from the Figure 4.4 to Figure 4.7, the angle of master and slave youBot will reach to same angle. This means those bilateral master-

slave telerobotic arm manipulator system has achieved the differential mode which obey the Equation 3.4. However, for bilateral system with $K_p=20$ and $K_p=50$, the angle of master and slave arm never reach the same angle and fluctuated all the time. This shows these two values of proportional term is not suitable to be used in P controller, and have not achieve the differential mode of bilateral system.

Next, from the four value of proportional terms which achieved differential mode, it can see that the smallest steady-state error from the reference angle is when the $K_p=5$. As shown in Figure 4.5, the final angle of master and slave is 3.25 rad, and the settling time is approximately at 1.2s which consider the fastest to reach stable. The second closer to reference angle is when $K_p=8$ as shown in Figure 4.6, while the third closer is when $K_p=1$ and the last one is when $K_p=10$. As shown in Figure 4.4, as value for $K_p=1$ is too small, the rise time of slave youBot arm is takes too long to track the motion of master arm. This happens when master youBot arm is being moved and reach reference angle at 1.25s, but slave youBot react too slow to follow the master youBot arm motion causes the master youBot arm to follow back the slave youBot arm. As a result the final angle is far from the reference angle. While in Figure 4.7, the graph shows that both master and slave youBot arm has fluctuated before they comes to steady state.

Accuracy and time-delay between master and slave youBot arm are calculated using the Equation 3.8 and 3.9 as stated in analysis method from chapter 3. The result is plotted in Table 4.1. Referring to the Table 4.1, the most accurate between master and slave youBot arm is when $K_p=5$, which reached 99.7526% while the least accurate system is when $K_p=50$ which is merely 55.7752%. Although it is the least accurate system, it has the shortest time delay which is only 0.1767s and the longest time-delay is 0.5344s when $K_p=1$, this is because the larger the value of K_p , the shorter the rise time.

Table 4.1: Accuracy result for P control system

Proportional term, K_p	Accuracy(%)	Time-Delay(s)
1	99.4393	0.5344
5	99.7526	0.2273
8	99.7367	0.2130
10	99.6197	0.2050
20	94.1138	0.1855
50	55.7752	0.1767

In short, for bilateral master-slave teleoperated arm manipulator system with P controller, the most suitable proportional value is when $K_p=5$ as it obeys common and differential mode, has critical damping characteristic, near to zero steady-state error, settling time is 1.2s which is the fastest among them, possesses high accuracy and short time-delay between master and slave arm.

In section two, the experiment is still the same but PD controller is used instead of P controller. The experiment is repeated by using different value of proportional term, K_p and derivative term, K_d . The proportional term, K_p is used the same value as the previous P controller experiment, and derivative term, K_d is adjusted until the most stable and best performance via experimental tuning. The experiment's result of using PD controller is presented in Figure 4.10 to Figure 4.15.

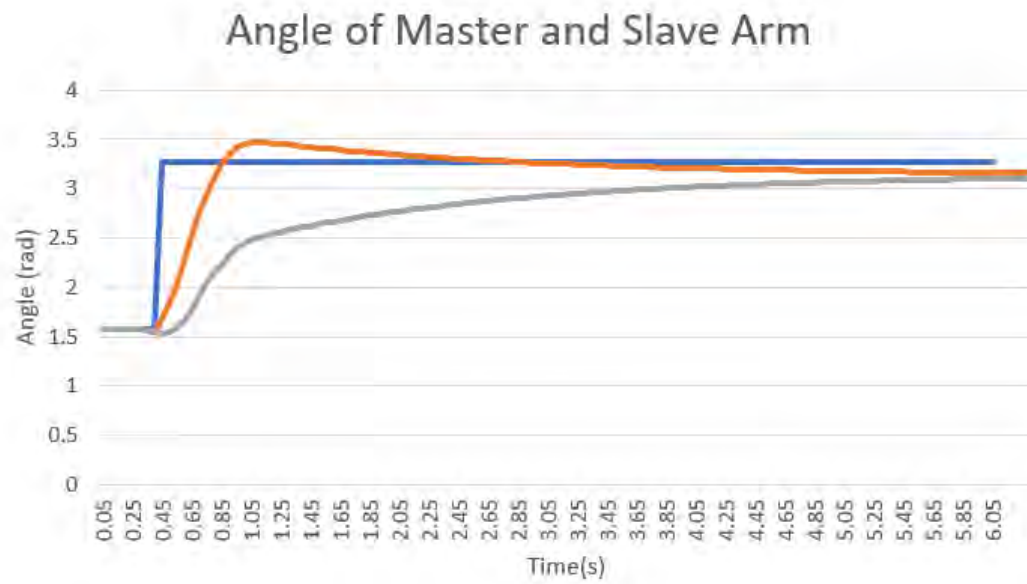

Figure 4.10: Angle of from master and slave arm rotated from its original position with value of $K_p=1$ and $K_d=0.8$.

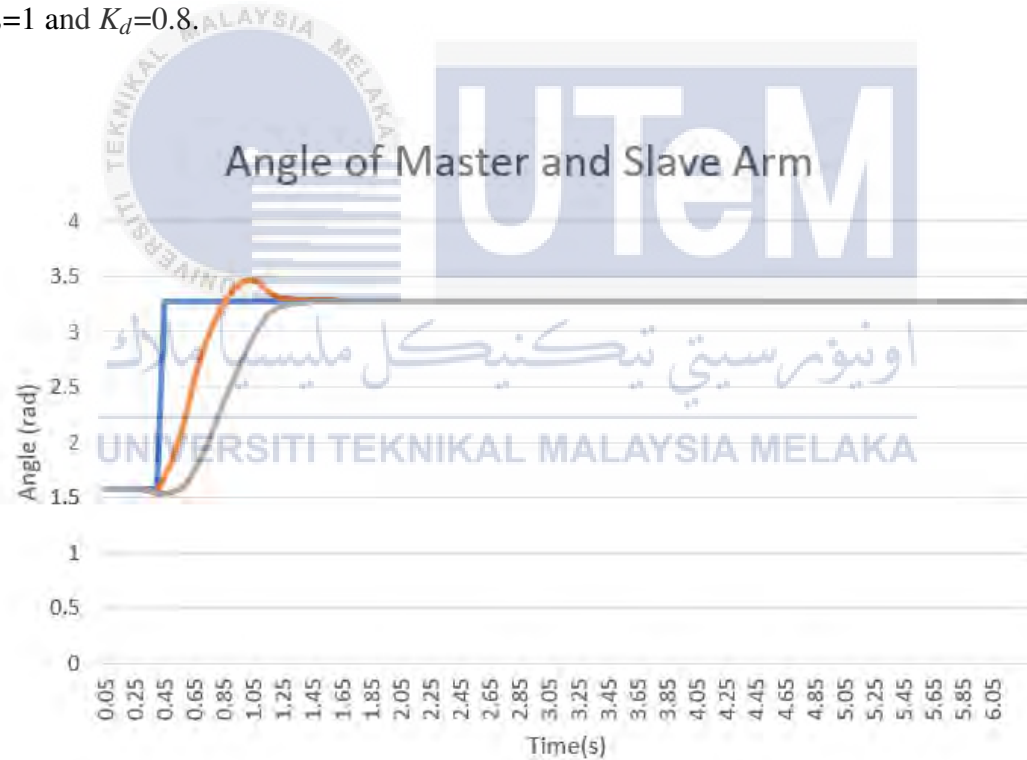

Figure 4.11: Angle of from master and slave arm rotated from its original position with value of $K_p=5$ and $K_d=0.1$.

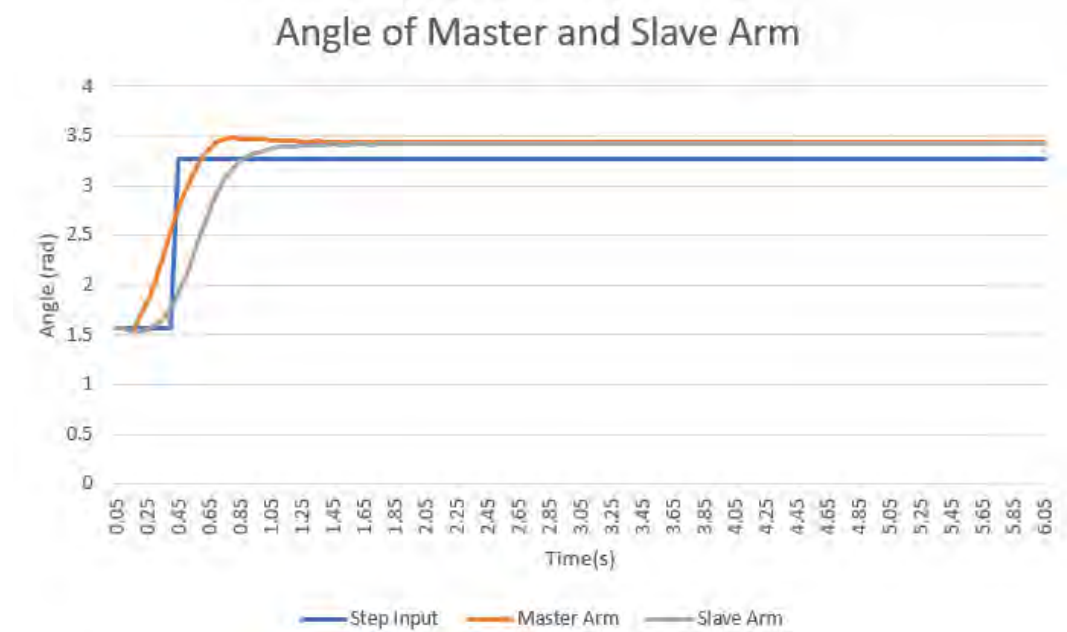

Figure 4.12: Angle of from master and slave arm rotated from its original position with value of $K_p=8$ and $K_d=0.5$.

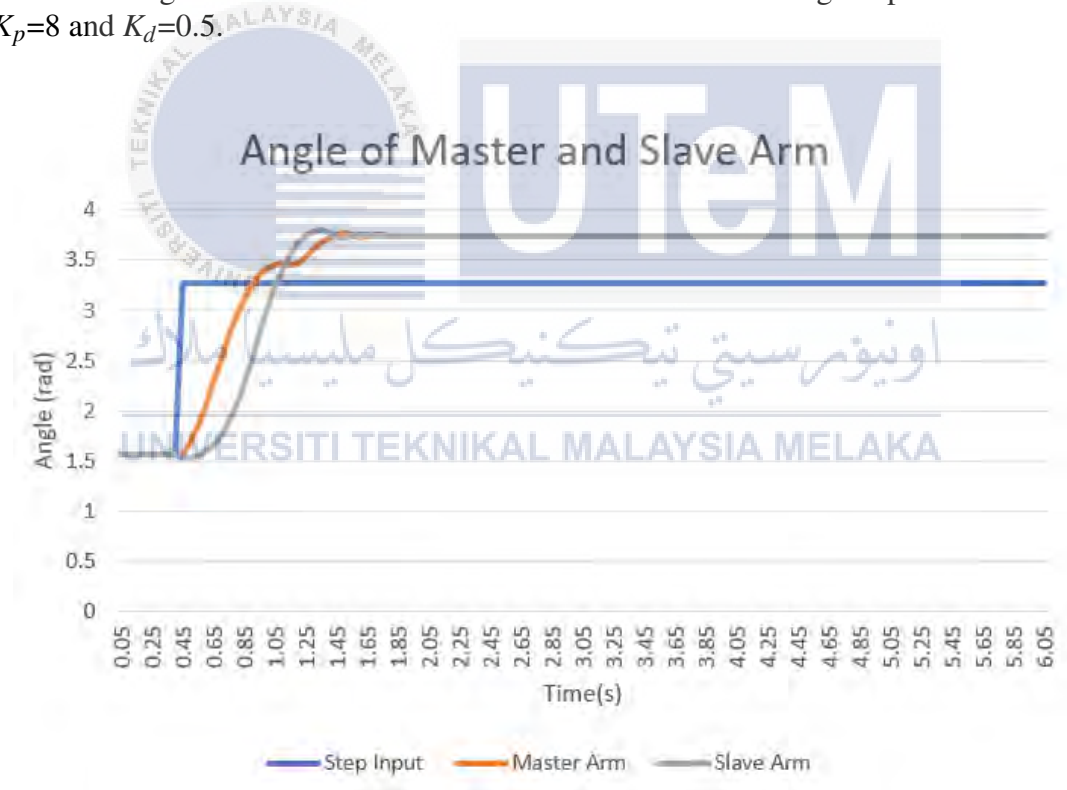

Figure 4.13: Angle of from master and slave arm rotated from its original position with value of $K_p=10$ and $K_d=0.2$.



Figure 4.14: Angle of from master and slave arm rotated from its original position with value of $K_p=20$ and $K_d=1.6$.

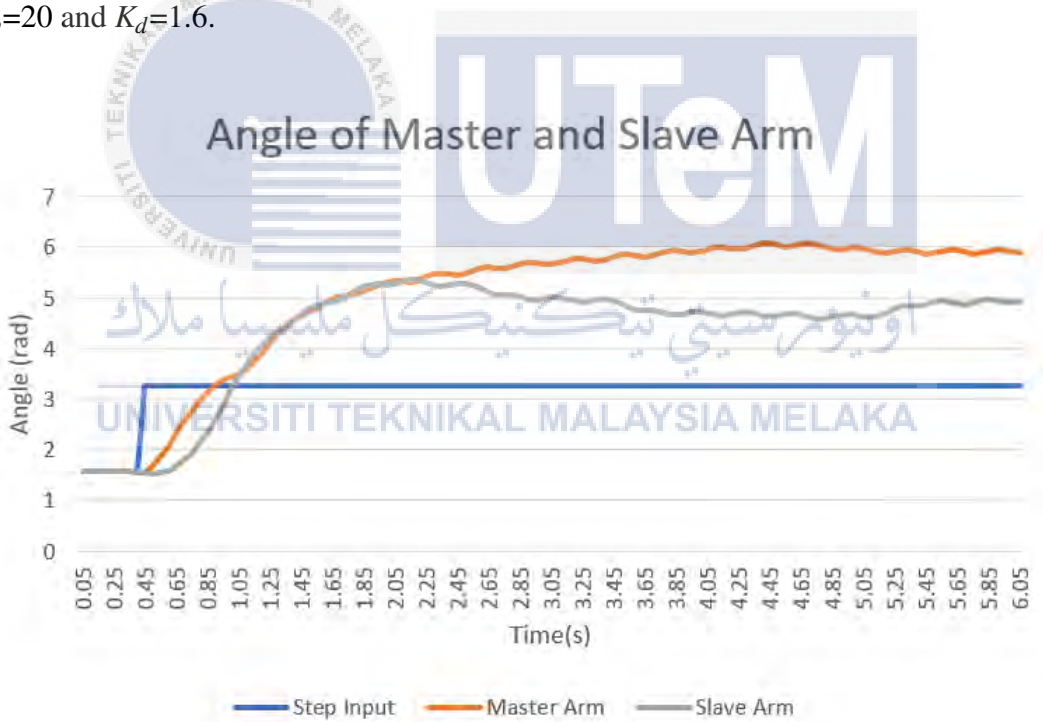

Figure 4.15: Angle of from master and slave arm rotated from its original position with value of $K_p=50$ and $K_d=4.65$.

According to above six plotted graph from Figure 4.10 to Figure 4.15, it can shows that every bilateral system has achieve differential mode and obey Equation 3.4 except for Figure 4.15. When $K_p=50$ and $K_d=4.65$, although the slave youBot arm has tried to track and follow the motion of master youBot arm at the first 2 second, but their angle difference

between master and slave become bigger. This fluctuated situation is hardly achieve the differential mode of bilateral system. When $K_p=20$ and $K_d=1.6$, the steady state angle is approximately between 4 rad to 4.5 rad, and the master and slave youBot arm has suffering from vibration all the time which makes the system unstable.

From the observation of graphs, when $K_p=5$ and $K_d=0.1$, master and slave youBot arm achieved zero steady state error in which the steady state angle is 3.27 angle exactly same as reference angle. The settling time for the system is approximately 1.3s which is the fastest among experiment using PD controller. When $K_p=1$ and $K_d=0.8$, the final angle achieved is 3.14 rad which is second closer to the reference angle, while when $K_p=8$ and $K_d=0.5$ comes the third closer and when $K_p=10$ and $K_d=0.2$ is the fourth closer to reference angle. Obviously, the settling time when $K_p=8$ and $K_d=0.5$, and $K_p=10$ and $K_d=0.2$ are shorter than system with $K_p=1$ and $K_d=0.8$, however those two systems suffering some vibration or fluctuation before they reach to their steady-state.

Accuracy and time-delay between master and slave youBot arm are calculated using the Equation 3.8 and 3.9 as stated in analysis method from chapter 3. The result is plotted in Table 4.2. The highest accuracy of system is when $K_p=10$ and $K_d=0.2$, which reached 99.9996% and the shortest time-delay is 0.1699s. The least accurate system is when $K_p=50$ and $K_d=4.65$, however it reached 86.4099% which improves 30% compare to P control system after adding the derivative term, K_d .

Table 4.2: Accuracy result for PD control system

Proportional term, K_p	Derivative term, K_d	Accuracy(%)	Time-Delay(s)
1	0.80	98.0596	0.1909
5	0.10	99.9226	0.2075
8	0.50	99.2424	0.1850
10	0.20	99.9996	0.1866
20	1.60	97.8503	0.1699
50	4.65	86.4099	0.1780

In short, in experiment using PD controller, the most suitable value for proportional term and derivative term are $K_p=5$ and $K_d=0.1$. This is because it has achieved differential mode, zero steady-state error, shortest settling time, high accuracy and acceptable time-delay between master and slave youBot arm.

In section three, the experiment is carried out using PID controller. The experiment is repeated by using different value of proportional term, K_p , derivative term, K_d and integral term, K_i . The proportional term, K_p and derivative term, K_d are used the same value as the previous PD controller experiment, and integral term, K_i is adjusted for the most stable state via experimental tuning. The experiment's result of using PID controller is presented in Figure 4.16 to Figure 4.21 which including different value for its position gain.

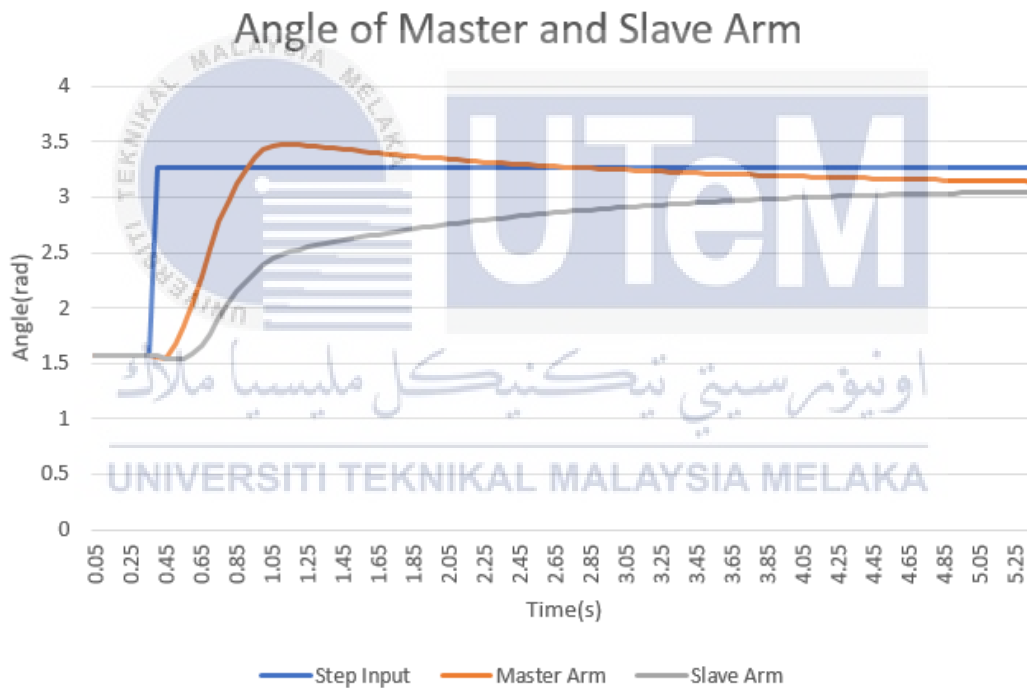

Figure 4.16: Angle of from master and slave arm rotated from its original position with value of $K_p=1$, $K_d=0.8$ and $K_i=0.01$.

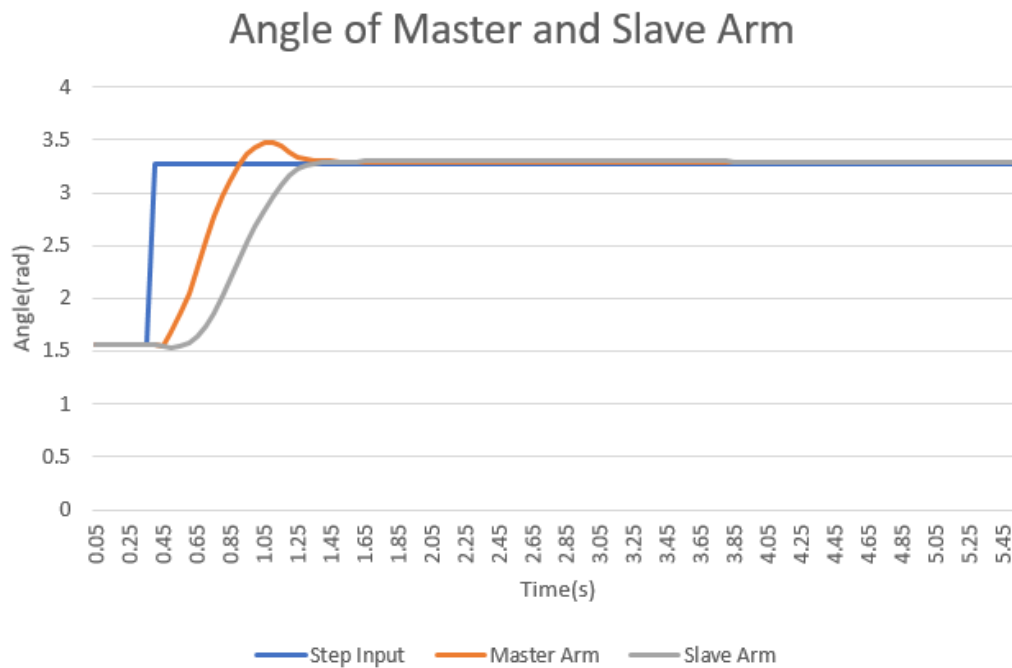

Figure 4.17: Angle of from master and slave arm rotated from its original position with value of $K_p=5$, $K_d=0.1$ and $K_i=0.001$.

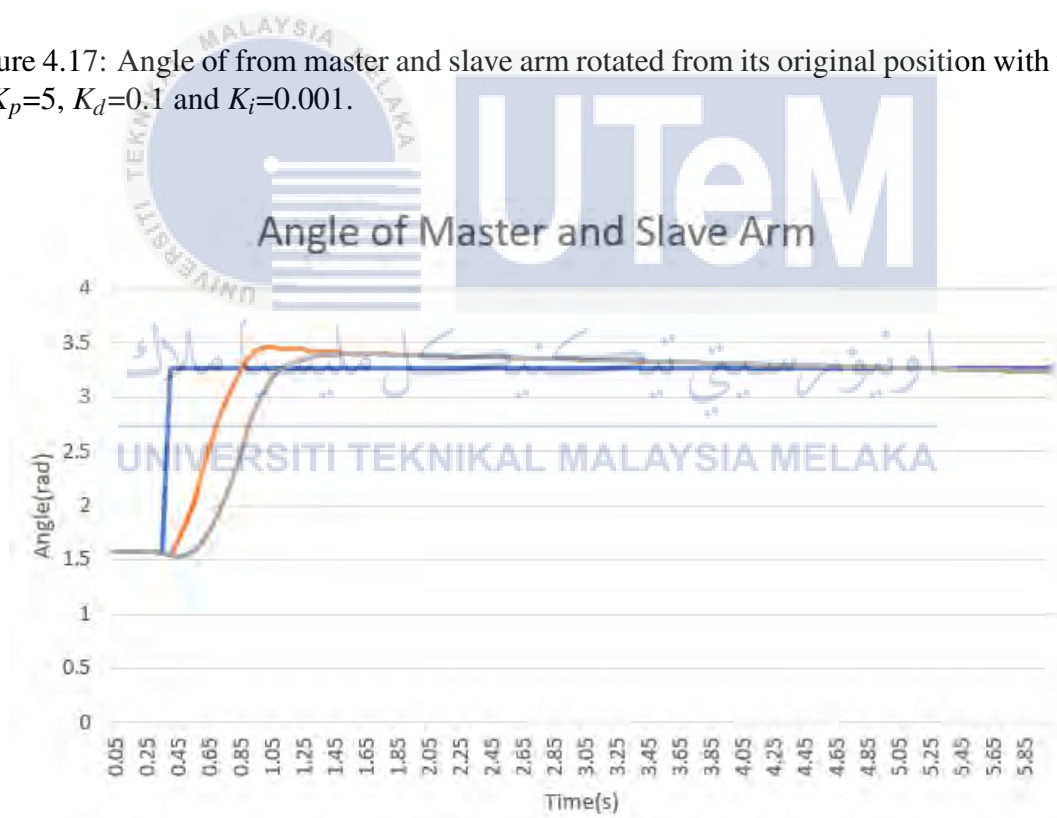

Figure 4.18: Angle of from master and slave arm rotated from its original position with value of $K_p=8$, $K_d=0.5$ and $K_i=0.005$.

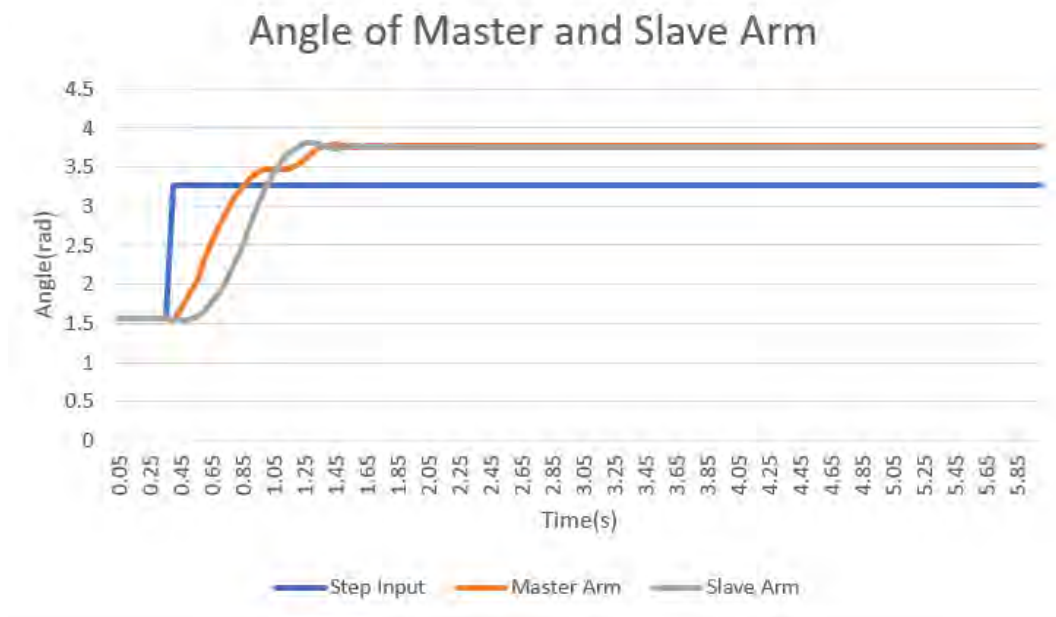

Figure 4.19: Angle of from master and slave arm rotated from its original position with value of $K_p=10$, $K_d=0.2$ and $K_i=0.0005$.

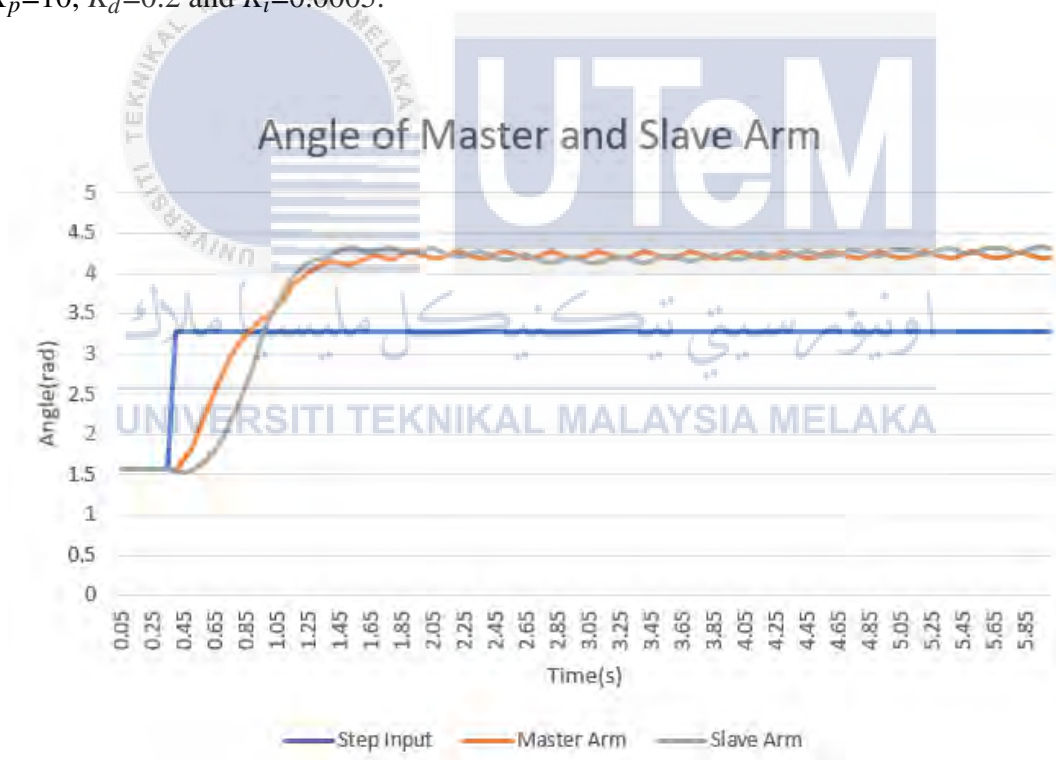

Figure 4.20: Angle of from master and slave arm rotated from its original position with value of $K_p=20$, $K_d=1.6$ and $K_i=0.005$.



Figure 4.21: Angle of from master and slave arm rotated from its original position with value of $K_p=50$, $K_d=4.65$ and $K_i=0.05$.

According to above six plotted graph from Figure 4.16 to Figure 4.21, it can show that every bilateral system has achieved differential mode and obey Equation 3.4 except for Figure 4.21. When $K_p=50$, $K_d=4.65$ and $K_i=0.05$, the graph shows that the slave youBot arm is trying to follow the master youBot arm, but still the gap between their angle difference is too large. This problem makes the system not qualified to obey the differential mode. Whereas in Figure 4.20 for a controller with $K_p=20$, $K_d=1.6$ and $K_i=0.005$, the steady-state angle has approximately 1 rad difference from the reference angle, which is quite a serious steady-state error. Moreover, the master and slave youBot arm has small vibrating when they reached their steady-state, which means the system is not stable enough.

From the observation of graphs, Figure 4.16 shows that the system has about 0.2 rad steady-state error, which Figure 4.19 has approximately 0.5 rad steady-state error. This is quite a big difference from the reference angle which shows that the system does not perform well. Figure 4.11 and Figure 4.18 show a very good accuracy, which is near to zero steady-state error. However, it is obvious that the system in Figure 4.11 shows a better performance as it has a very short settling time which is about 1s whereas the system in Figure 4.18 needs about 5s to reach steady-state.

Accuracy and time-delay between master and slave youBot arm are calculated using the Equation 3.8 and 3.9 as stated in analysis method from chapter 3. The result is plotted in Table 4.3. There are two system has reached over 99% but the system with $K_p=10$, $K_d=0.2$, and $K_i=0.05$ has outperformed the others which reached 99.8894%. Whereas, the shortest time delay is the system with $K_p=20$, $K_d=1.6$, and $K_i=0.005$ which only 0.169s.

Table 4.3: Accuracy result for PID control system

Proportional, K_p	Derivative, K_d	Integral, K_i	Accuracy(%)	Time-Delay(s)
1	0.80	0.0100	97.1355	0.1921
5	0.10	0.0010	99.6340	0.2072
8	0.50	0.0050	97.8074	0.1876
10	0.20	0.0005	99.8894	0.1873
20	1.60	0.0050	99.1817	0.1690
50	4.65	0.0500	87.5241	0.2380

In short, in experiment using PID controller, the most suitable value for proportional term, derivative term and integral term are $K_p=5$, $K_d=0.1$ and $K_i=0.001$. This is because it has achieved differential mode, zero steady-state error, and shortest settling time, high accuracy and acceptable time delay.

As comparison between the results of using P control, PD control, and PID control, it can come to some conclusion. For information, the derivative term, K_d is used to reduce the overshoot, hence when compare the Figure 4.14 and Figure 4.20 to Figure 4.8, it can be seen that after the derivative term, K_d is added to P controller, it helps to reduce the fluctuation of master and slave youBot arm and stabilise the system. Moreover, it is known that function of integral term, K_i is used to eliminate the steady-state error. This can be proved when integral term, K_i is added to Figure 4.12 and Figure 4.15, the final angle of master and slave youBot arm tend to be closer to the reference angle as shown in Figure 4.18 and Figure 4.21. However, from each P, PD and PID control system, the best system for each controller is when $K_p=5$ for P controller, $K_p=5$ and $K_d=0.1$ for PD controller, and $K_p=5$, $K_d=0.1$ and

$K_i=0.001$ for PID controller. Overall, three of these system has reached over 99% accuracy between master and slave arm and acceptable time-delay which is around 0.2s. Also, these three system has the best performance in term of precision to reference angle and settling time. To compare amongst the three best system, PD control with $K_p=5$ and $K_d=0.1$ has the best precision to reference angle as it is exactly 3.27 rad in steady-state while P control is 3.25rad and PID control is 3.28rad in steady-state. However, PID controller with $K_p=5$, $K_d=0.1$ and $K_i=0.001$ has the shortest settling time that is 1s compare to P control system with 1.2s and PD control system with 1.3s settling time. This is because integral term, K_i has the function in reducing the settling time. Hence, depending on the requirement of the system needs, PD control is highly recommended for precise control, and PID control could be used if fast reaction is required.

4.4 Summary

In short, common mode and differential mode for bilateral master-slave telerobotic arm manipulator system has been proved in the experiments. In addition, experiments for different types of controller such as P controller, PD controller, and PID controller has been carried out and all the data have been plotted in graph for analysis. From the analysis, the best controller for the bilateral master-slave telerobotic arm manipulator system is PD control system and PID control system. The most suitable parameter for PD controller are $K_p=5$ and $K_d=0.1$ which has the most precise control while $K_p=5$, $K_d=0.1$ and $K_i=0.001$ is the best value for PID controller which makes the system having the shortest settling time. Moreover, the calculation for accuracy and time-delay between master and slave arm about have been calculated for each controller. Overall, the designed system mostly reached over 90% accuracy and around 0.2s time delay only which is quite a high transparency in bilateral teleoperation system. In the next chapter, it will conclude this project and giving recommendation for further works to future research.

CHAPTER 5

CONCLUSION AND RECOMMENDATION FOR FUTURE RESEARCH

5.1 Conclusion

As conclusion, objectives have been achieved in this project. Firstly, the first objective is achieved in Chapter 2 by study the research papers from well-known researchers all over the world about bilateral master-slave telerobotic arm manipulator system. In the study process, a lot of methods used by researchers to develop bilateral system have been mentioned in this report and various future challenges have been stated for further improvement.

Next, the second objective is achieved by developing bilateral master-slave telerobotic arm manipulator system by using industrial robot, KUKA youBot in V-REP software simulation. The bilateral system has been proved by carrying experiments. Experiments has been divided into two parts. The first part of experiment has been carried out, and force data from master and slave youBot arm are extracted for doing analysis. Finally, the performance of common mode has been validated. In the second part of experiment, the angle data from master and slave youBot arm is used to plot in graph for analysis, and this results that the performance of differential mode also been proved. As the basic requirement for common mode and differential mode has been validated, the development of bilateral master-slave telerobotic arm manipulator system is success.

Finally, the third objective is achieved by carrying out the experiments in part two by using different kind of controllers which includes P controller, PD controller, and PID controller. From each controller, various value of proportional term, K_p , derivative term, K_d , and integral term, K_i are used in the effort of finding the best controller system in the

end. Analysis has been done for various performance including, accuracy between master and slave youBot arm, time-delay between master and slave youBot arm, precision of arm to the reference angle, and last the settling time. Overall, most of the system achieved very high accuracy between master and slave youBot arm in simulation which is over 95%. The time delay of overall is around 0.2s which is quite short. However, the precision of youBot rotated angle to the reference angle and the settling time has showed in huge difference with different control system and different value of proportional term, K_p , derivative term, K_d , and integral term, K_i . After doing the analysis, it can be concluded that the most suitable controllers are using the PD controller with $K_p=5$ and $K_d=0.1$ for the most precise control with zero steady-state error, or PID controller with $K_p=5$, $K_d=0.1$ and $K_i=0.001$ with little steady-state error but with shortest settling time which is 1s.

5.2 Future Work

Although the development of bilateral master-slave telerobotic arm manipulator system in KUKA youBot is successful in V-REP simulation, there is always different cases in the real practice. Hence, for the future research, the system designed in this project can be used to develop in the real KUKA youBot, observe, and analyses the differences of performance between the real practice and the simulation. If the result is not optimum due to the value of proportional term, K_p , derivative term, K_d , and integral term, K_i , it may required to do the tuning again for the real practice. For future researchers, it is recommended to use Matlab Robotics System Toolbox to design the control system which is quite a new toolbox designed by Matlab which can used in simulation and real practice. However, it needs license for Matlab software to having that particular toolbox, and it may need to create own library for KUKA youBot since the library is not readily available for this toolbox yet.

Moreover, future researchers may develop the bilateral master-slave telerobotic arm manipulator system by using other control system such as using disturbance observer(DOB) or using artificial intelligence method such as fuzzy logic control and neural networks. Disturbance observer(DOB) is a well-known method used to estimate the external disturbance itself which is very efficient for precise control.

REFERENCES

- [1] R. J. Anderson and M. W. Spong, "Bilateral Control of Teleoperators with Time Delay," *IEEE Transactions on Automatic Control*, vol. 34, no. 5, pp. 494–501, 1989.
- [2] C. Hua and X. P. Liu, "Teleoperation over the internet with/without velocity signal," *IEEE Transactions on Instrumentation and Measurement*, vol. 60, no. 1, pp. 4–13, 2011.
- [3] S. Islam, P. X. Liu, A. El Saddik, and Y. B. Yang, "Bilateral control of teleoperation systems with time delay," *IEEE/ASME Transactions on Mechatronics*, vol. 20, no. 1, pp. 1–12, 2015.
- [4] Y. Ye and P. X. Liu, "Improving trajectory tracking in wave-variable-based teleoperation," *IEEE/ASME Transactions on Mechatronics*, vol. 15, no. 2, pp. 321–326, 2010.
- [5] I. G. Polushin, P. X. Liu, and C. H. Lung, "A force-reflection algorithm for improved transparency in bilateral teleoperation with communication delay," *IEEE/ASME Transactions on Mechatronics*, vol. 12, no. 3, pp. 361–374, jun 2007.
- [6] The New Internationalist All Posts RSS, "Issue On Landmines. This Fact Sheet Provides Statistics On Landmines And Their Victims, Including Where Landmines Are Manufactured, Where They Are Planted, And Who Gets Hurt By Them." 1997. [Online]. Available: <https://newint.org/features/1997/09/05/facts/>. [Accessed 2016-9-9].
- [7] M. Allen, "How Many Die From Medical Mistakes in US Hospitals?" p. 2014, 2013. [Online]. Available: <https://www.scientificamerican.com/article/how-many-die-from-medical-mistakes-in-us-hospitals/>. [Accessed 2016-9-16].
- [8] D. Tian, D. Yashiro, and K. Ohnishi, "Wireless haptic communication under varying delay by switching-channel bilateral control with energy monitor," *IEEE/ASME Transactions on Mechatronics*, vol. 17, no. 3, pp. 488–498, 2012.
- [9] J. J. Craig, *Introduction to Robotics: Mechanics and Control*. Pearson Education International, 2004.
- [10] R. Kubo, N. Motoi, and K. Ohnishi, "Transparency and system connection for heterogeneous haptic network systems," *International Workshop on Advanced Motion Control, AMC*, pp. 709–714, 2010.
- [11] D.A.Lawrence, "Stability and Transparency in Bilateral Teleoperation," no. Robotics and Automation, pp. 624–637, 1993.
- [12] C. Zheng, P. Ya-Jun, and J. Gu, "Adaptive robust control of bilateral teleoperation systems with unmeasurable environmental force and arbitrary time delays," *Control Theory & Applications, IET*, vol. 8, no. 15, pp. 1456–1464, 2014.

- [13] N. Togashi, T. Shimono, N. Motoi, and N. Oda, "Experimental comparison of design methods for equivalent mass matrix in motion control system based on workspace observer," *International Workshop on Advanced Motion Control, AMC*, pp. 669–674, 2014.
- [14] A. Haddadi and K. Hashtrudi-Zaad, "Bounded-impedance absolute stability of bilateral teleoperation control systems," *IEEE Transactions on Haptics*, vol. 3, no. 1, pp. 15–27, 2010.



APPENDICES

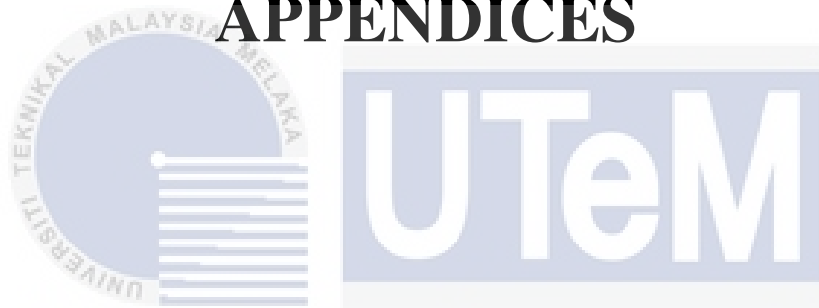

اونيورسيتي تيكنيكل مليسيا ملاك

UNIVERSITI TEKNIKAL MALAYSIA MELAKA