

“ I hereby declare that I have read through this report entitle “Controller Tuning By Using Optimization Technique For An Electro-Hydraulic Actuator System” and found that it has complied the partial fulfillment for awarding the degree of Bachelor of Electrical Engineering (Control, Instrumentation & Automation) With Honors ”

Signature:

Supervisor's Name: Nur Asmiza binti Selamat

Date:

**CONTROLLER TUNING BY USING OPTIMIZATION TECHNIQUE FOR AN
ELECTRO-HYDRAULIC ACTUATOR SYSTEM**

SYAIFUL SYHWAN BIN NASRI

**A report submitted in partial fulfilment of the requirements for the degree of Control
Instrument and Automation**

**Faculty of Electrical Engineering
UNIVERSITI TEKNIKAL MALAYSIA MELAKA**

YEAR 2015/2016

I declare that this report entitles “**Controller Tuning By Using Optimization Technique For An Electro-Hydraulic Actuator System**” is the result of my own research except as cited in the references. The report has not been accepted for any degree and is not concurrently submitted in candidature of any other degree.

Signature:

Name:

Date:

To my beloved mother and father

ACKNOWLEDGEMENT

In the name of Allah, the Most Beneficent and The Most Merciful. It is deepest sense gratitude to the Almighty that gives me strength and ability to complete this final report.

First of all I would like to express my gratitude to my supervisor, Madam Nur Asmiza binti Selamat for his valuable guidance and support throughout this semester until this report completes successfully.

My utmost thanks also go to my family Nasri Bin Mokhtar, my beloved father and Suzana Bte Mat Din, my lovely mother for their support and love. Not to forget my other family and friends. My fellow postgraduate students should also be recognized for their support. My sincere appreciation also extends to all my colleagues and others who have provided assistance at various occasions. Their views and tips are useful indeed. Unfortunately, it is not possible to list all of them in this limited space. I am grateful to all my family members.

ABSTRACT

Nowadays, the application that use of Electro Hydraulic Actuator (EHA) system in the industrial sector has been widely applied. This is because the system produces high power to weight ratio, smaller size, and faster responds than existing CHA (Conventional Hydraulic Actuator) system. The EHA system has been developed to replace the CHA system that has some problem such as leakage of the working fluid, maintenance load, heavy weight and limited installation space. However, the system of EHA system has produced nonlinearities and uncertainty characteristic. Therefore, to improve the performance, the parameter require to compensate the changes in EHA system. In this project, PID and LQR control tuning using PSO (Particle Swarm Optimization) by using Matlab coding. Other than that, the transient of performance in term of settling time, rise time and overshoot will be determine by compare both controllers. The performance index, integral of time square error (ITSE) will be used in optimization technique in order to find suitable parameter for PID and LQR. The last chapter, will be discussed which controllers will gives are better performance between PID and LQR with more precision and flexibility.

ABSTRAK

Pada masa kini, aplikasi yang menggunakan Elektro Hidraulik Penggerak sistem dalam sektor perindustrian telah digunakan secara meluas. Kerana system ini menghasilkan kuasa yang tinggi kepada nisbah berat, saiz yang lebih kecil, dan tindak balas lebih cepat daripada Hidraulik Konvensional Penggerak sistem yang sedia ada. Sistem Elektro Hidraulik Penggerak telah dibangunkan untuk menggantikan sistem Hidraulik Konvensional Penggerak yang mempunyai beberapa masalah seperti kebocoran bendalir kerja, beban penyelenggaraan, berat dan ruang pemasangan yang terhad. Walau bagaimanapun, system Elektro Hidraulik Penggerak telah menghasilkan parameter tak lurus dan ciri-ciri yang tidak menentu. Walaubagaimanapun, system EHA ini telah menghasilkan system tak terlelurus dan ciri-ciri yang tidak menentu. Oleh itu, untuk meningkatkan prestasi, memerlukan imbagi parameter kepada perubahan dalam system EHA. Dalam projek ini *Proportional Integral Derivative (PID)* and *Linear Quadratic Regulator (LQR)* telah digunakan pada *Particle Swarm Optimization (PSO)* dengan menggunakan kaedah Matlab. Selain itu, prestasi sementara akan dinilai dari segi peratusan terlajak waktu penyelesaian, waktu naik dan ralat keadaan mantap akan dikenal pasti untuk perbandingan kedua-dua kawalan. Indeks prestasi, *Integral Time Square Error (ITSE)* akan digunakan dalam dalam teknik optimum untuk mencari parameter yang sesuai untuk kawalan PID dan LQR. Di bab yang terakhir, akan dibincangkan kawalan yang mana akan memberi percapaian percapaian yang terbaik diantara PID dan LQR dengan lebih fleksibel dan lebih tepat.

TABLE OF CONTENT

CHAPTER	TITLE	PAGE
	ACKNOWLEDGEMENT	i
	ABSTRACT	ii
	ABSTRAK	iii
	TABLE OF CONTENT	iv
	LIST OF TABLE	vii
	LIST OF FIGURE	viii
1	INTRODUCTION	1
	1.1 Introduction	1
	1.2 Motivation	2
	1.3 Problem statement	2
	1.4 Objective of project	3
	1.5 Scope of project	3
	1.5 Project Outlines	3
2	LITERITURE REVIEW	4
	2.1 Introduction	5
	2.2 Electro Hydraulic Actuator (EHA) System Background	5
	2.2.1 Description of EHA system background	
	2.3 EHA system operation	6
	2.4 Control strategy in the EHA	7
	2.5 Application for EHA system	8
	2.6 Control of EHA system	9
	2.6.1 Proportional, Integral, and Derivative (PID)	10
	2.6.2 Fuzzy logic control	11

	2.6.3	Sliding mode control (SMC)	12
	2.6.4	Adaptive control system	13
	2.6.5	Linear Quadratic Regulator (LQR)	13
	2.7	Optimization technique	14
	2.7.1	Particle Swarm Optimization (PSO)	15
	2.7.2	Genetic Algorithm (GA)	15
	2.7.3	Imperialist competitive algorithm	16
3		METHODOLOGY	18
	3.1	Introduction	18
	3.2	Flow of the study	18
	3.3	Mathematical model of EHA system.	19
	3.4	Design LQR and PID Controller	21
	3.4.1	LQR Controller	21
	3.4.2	PID Controller	24
	3.5	LQR and PID Control Tuning using Optimization Technique.	25
	3.6	Optimization Technique	26
	3.6.1	Particle Swarm Optimization (PSO) technique.	26
	3.7	Objective Function	30
	3.8	Simulation Process	31
	3.9	Disturbance test	33
	3.10	Conclusion	35
4		RESULT AND DISCUSSION	36
	4.1	Introduction	36
	4.2	Expected Open-Loop and Close-Loop from Simulation Result	36
	4.3	Selection of PSO parameter	39
	4.4	PSO for LQR and PID	39
	4.4.1	Parameter for PID and LQR	43
	4.5	Comparison between LQR and PID	44
	4.5.1	Statically estimation from ITSE	47
	4.6	Controller system tuning using PSO with disturbance	47

4.61	Parameter for LQR and PID with disturbance	50
4.6.2	Comparison between PID and LQR with disturbance	51
4.7	System response comparison with disturbance and without disturbance	55
4.8	Conclusion	57
5	CONCLUSIONS	58
5.1	Introduction	58
5.2	Conclusion	58
5.3	Future work	59
	REFERENCES	60

LIST OF TABLE

NO.	TITLE	PAGE
2.1	Comparison between K_p , K_i and K_d	10
2.2	Function block diagram Fuzzy Logic Controller.	12
3.1	Gantt chart for research methodology	29
4.1	Data transient response for model with step input	37
4.2	Data transient response for model with unity feedback	38
4.3	Number of Particles Selection	39
4.4	LQR data with 10 executions using PSO	41
4.5	PID data with 10 executions using PSO	42
4.6	Parameter value for LQR and PID	43
4.7	Comparison between LQR and PID	46
4.8	Comparison of statically estimation	46
4.9	LQR data with 10 executions using PSO with disturbance	48
4.10	PID data with 10 executions using PSO with disturbance	49
4.11	Parameter value for LQR and PID with disturbance	51
4.12	Comparison between LQR and PID with disturbance	53
4.13	Comparison of statically estimation	54
4.14	System Response PID with disturbance and without disturbance	55
4.15	System Response PID with disturbance and without disturbance.	56

LIST OF FIGURE

NO.	TITLE	PAGE
2.1	Schematic of the EHA hydraulic circuit	7
2.2	Control block diagram for the EHA	7
2.3	Injection molding and die casting machines	8
2.4	Wind turbine circuit diagram	9
2.5	The fuzzy logic controller block diagram	11
2.6	The optimization flowchart of GA technique	16
2.7	Flowchart of the propose algorithm	17
3.1	Schematic diagram for LQR	21
3.2	Schematic diagram for PID	25
3.3	LQR Control Tuning block diagram	25
3.4	PID Control Tuning block diagram	26
3.5	Diagram of controller with optimization technique	27
3.6	Flow of chart of PSO technique	28
3.7	Flow of process PSO	32
3.8	Disturbance Input	33
3.9	Disturbance for Signal Input	33
3.10	PID controller system with Disturbance	34
3.11	LQR controller system with Disturbance	34
4.1	Response of the model with step input	37
4.2	Response of the model with unity feedback.	38
4.3	Graph of ITSE versus number of particle for (LQR) with EHA system	39
4.4	Graph of ITSE versus number of particle for (PID) with EHA system	40
4.5	Graph of ITSE versus number of simulation for LQR	41

4.6	Graph of ITSE versus number of simulation for PID	42
4.7	Respond for LQR controller	44
4.8	Respond for LQR controller	45
4.9	Comparison System Performance	45
4.10	Performance comparison between LQR and PID controller	46
4.11	Performance index for LQR with disturbance.	49
4.12	Performance index for LQR with disturbance.	50
4.13	Respond for LQR controller with disturbance	51
4.14	Respond for PID controller with disturbance	52
4.15	Combination Respond between PID and LQR controller with disturbance	52
4.16	Performance comparison between LQR and PID controller with disturbance	53
4.17	Step Response of PID PSO Algorithm	55
4.18	Step Response of PID PSO Algorithm	56

CHAPTER 1

INTRODUCTION

1.1 Introduction

Nowadays, the application Electro Hydraulic Actuator (EHA) has been widely used in the industrial sector. This is because the system produces high power to weight ratio, smaller size, and faster responds than existing CHA (Conventional Hydraulic Actuator) system. The EHA system has been developed to replace the CHA system that identified to cause a problem such as leakage of fluid during working with involve big and heavy equipment that applies with CHA or running the application, high maintenance cost part that applies in CHA heavy and limited space for installation. Moreover, the performance of the EHA system in term of position control requires an accurate EHA to determine the position and robustness of the controller. Besides that, the system need to develop and make sure that robustness and tracking accuracy is significant with desired output. However, the system with application of EHA system has produced nonlinearities and uncertainty characteristic. These effects emerge from the friction and internal fluid leakage system. To perform the performance of EHA, a suitable controller need to be designed in order to achieve the desired output of the system. The output response of two different type of controller will be applied to EHA system. The LQR and PID will be designed as a controller of the nonlinearities and uncertainties to improve the performance of the EHA system. Optimization technique Particle Swarm Optimization (PSO) technique will be use in this study to optimize the parameters of LQR and PID Controller.

1.2 Motivation

The application of EHA system technology has spread into many different fields including robotics, aircraft, manufacturing system and etc. Due to higher performance of the EHA system in term of position and pressure the nonlinearities and uncertainties characteristic have to be considered. The intelligent controller tuning will be used in the EHA system to improve the performance of the EHA system. Optimization technique will be used in this project to acquire the best parameter tuning. PID and LQR were chosen to apply in the Electrohydraulic Actuator system. The advantage of using PID which is having a wide range of application in industrial control while the advantages of LQR is the system always be stable and robust.

1.3 Problem Statement

An Electro Hydraulic System is one of important application in the industrial sector and engineering practice. The advantages of EHA system its high power to weight ratio and stiffness response being good, smooth and fast. However the EHA system has a problem in terms of friction and internal fluid leakage. It happen because the system is highly nonlinear [8]. Other than that, the effects of nonlinearities and uncertainties will degrade the performance of the system in terms of robustness and tracking performance. Hence proper selection of controller are crucial at which it will improve the performance since the performance of EHA will degrade the controller. The parameter required a change to compensate the changes in EHA system. Manual trial that still being used nowadays are not efficiency because trial and error method not good technique if the problems situation doesn't gives multiple changes to find a solution and sometime need to repeat many times to get best parameter. Hence this project will use the optimization technique to tune the selected controller parameter.

1.4 Objective of Project

The aim of this project is to obtain the parameter for the LQR and PID tuning for Electro Hydraulic System (EHA) using optimization technique. Therefore the objectives are.

1. To implement LQR and PID controller to EHA system and tune controller parameter using PSO.
2. To compare system performance in term of index, Overshoot, Settling Time, Rise Time and precision of the controller.

1.5 Scope of project

In order to achieve the objective of the project, several scopes of project have been outlined:

- The LQR and PID controller are chosen as the controller of the nonlinearities and uncertainty model of EHA system.
- The LQR and PID parameters will be tuned using optimization technique which is Particle Swarm Optimization.
- ITSE will be used as the performance index to the system performance for both LQR and PID will be compare in term of performance index response (Settling Time, Rise Time and Overshoot) and precision.
- All simulation work will be shown using MATLAB software.

1.6 Project outlines

This report basically divided into five chapters which is chapter 1 is an introduction, chapter 2 is a literature review, chapter 3 is a methodology, chapter 4 is a result and discussion and lastly chapter 5 is a conclusion and future works.

Chapter 1 will introduces the readers with the basic aspect of the research done, such as the overview of the electrohydraulic actuator system, problem statements, objective and scopes of the project. Chapter 2 will reviews the basic principle of the system, related previous work and other reviews related to this project. Chapter 3 will show the flow of the study and methodology related to this study. Chapter 4 will present the result of the system performance by using LQR and PID controller by using PSO. Both of the controllers will be tested with disturbance. Chapter 5 consist of the conclusion based on the overall works and results and include some future improvement that can be done in the system.

CHAPTER 2

LITERATURE REVIEW

2.1 Introduction

This chapter describes the literature review for Electro Hydraulic Actuator (EHA) system. This stage will review related previous work and other related to this project which are EHA system background, EHA system operation, control strategy in the EHA, application for EHA system, controller of EHA systems and lastly optimization technique. The observation from this chapter will determine for the next chapter is a methodology.

2.2 Electro Hydraulic Actuator (EHA) System Background

2.2.1 Description of EHA System Background.

An Electro Hydraulic Actuator (EHA) system is driven systems are central factors in industrial process and engineering practice. Electro hydraulic actuator system has been widely used in industry because of a like large dynamic system to guarantee the performance of the system [1]. It is because the system working under high speed condition and fulfil the requirement of standard industry ,include their ability to produce large force at high speed during durability and stiffness and their rapid response[2], [3]. However, the system is faster responding than the existing conventional hydraulic actuator (CHA) system [4]. The system

that is being applied in CHA commonly used as power units. In addition, ability to generate very large power compared to their size. The basic function of CHA is to transfer the working fluid and an actuator. Devices that creates a mechanical motion by converting into various form of energy into mechanical energy known as actuator. The problem are faced in CHA system firstly is environmental. The leakage of the working fluid maintenance caused the pollution. In addition, the leakage occurs when high pressure during working fluid. It is between joint of pump, fluid conduits, manifold and fluid conduit. Secondly, the problem is heavy weight. Many parts of hydraulic system are more expensive. It is because the requirement to build and construct need a powerful pressure to operate the requirement system. Lastly is the limited space consumption system CHA. Basically, the system consists of many components and valves to operating. It necessity to improve the system of CHA like size, system maintenance and environmental pollution. EHA system was developed to replace the role of the CHA system with the best performance of the EHA in terms of position, force or pressure is needed [2].

2.3 EHA System Operation

The main components of EHA system include an electrical motor, pressure and position sensors, a bidirectional gear pump, a symmetrical actuator and an accumulator sub-circuit [5] based on Figure 2.1. The EHA uses a bi-directional, fixed displacement gear pump to supply oil to the actuator. The function of the electric motor to generate the flow rate by rotating the motor. The pressure that generated by flow rate will changes the position of the piston rod and also varying the speed of the motor. It is because when the flow encounter a resistance such as an actuator, the pressure on fluid will increase [6].The symmetrical actuator is connected with an external load. In addition, the motion of load can be control. The useful part to influence load is a motor, by controlling the speed of the electrical motor.

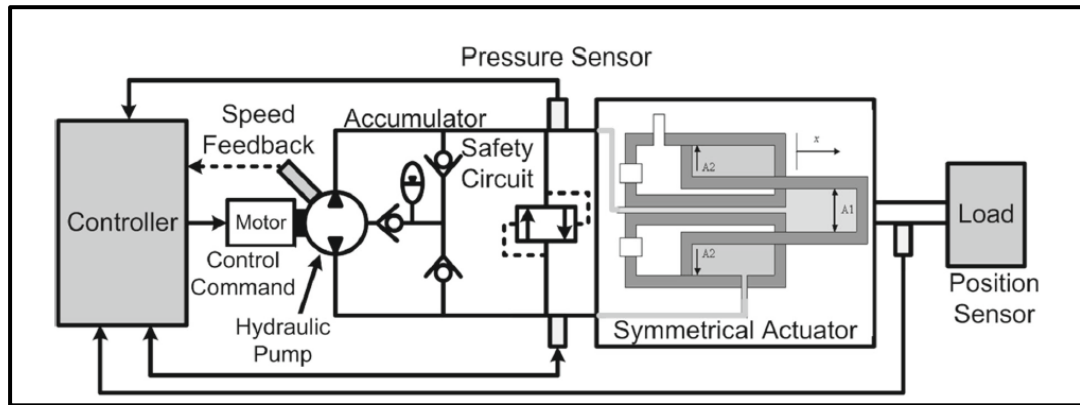

Figure 2.1: Schematic of the EHA hydraulic circuit [5].

2.4 Control Strategy in the EHA

The EHA position control system consist two hydraulic sub-circuit. Which is, outer loop and inner loop, as shown in Figure 2.2. Outer-circuit connected to the symmetrical actuator and an inner-circuit with low-pressure accumulator [6]. Inner loop for control the angular velocity control of the servo motor or pump and outer loop for the position control of the piston [4]. Inner loop is an important process because it regulate the electric motor to provide an accurate control into the pump flow. In addition, the friction occurred at pump-motor interface when flow control strategy desensitizes the system into dead-band. The outer loop is an important part in EHA system and to improve the performance and robustness of EHA in term of the position control system.

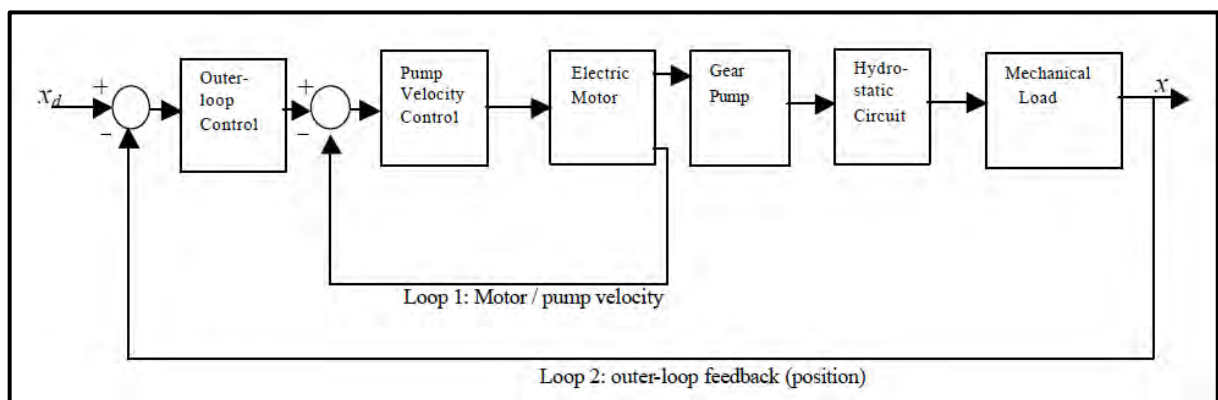

Figure 2.2: Control Block Diagram for the EHA [6].

2.5 Application for EHA System.

The use of EHA has spread into many different fields due to their advantages. Recently, with the research and development of the hydraulic control has been developed and used widely in many applications such as manufacturing system, material testing machineries, fatigue testing, flight simulation, paper machines, ship and electromagnetic marine, robotics, and steel and aluminums mill equipment [7].

The ability of EHA system such as high power to weight ratio, fast and smooth response characteristic, accurate positioning of heavy load, stiffness response and good power capabilities have increased the number use of EHA in industries. For an example injection molding machines as shown in Figure 2.3. Injection molding machines have several steps that needed to produce a product. The step is clamping, injection, dwelling, cooling, mold opening and removal of products. This method is suitable for production that produces with complicated shapes. Moreover, EHA system is the best way to implement in this method. This is because EHA produces high power to weight ratio and also accurate positioning for plastic processing. In addition, application of wind turbine also implement EHA system. The fundamentals and principles of hydraulic system used for wind turbines, such as for pitch control, yaw control, braking and cooling or filtration systems. For pitch control system, the function is to adjust the pitch turbine blade angle based on Figure 2.4. Basically, the technical feature electrohydraulic pitch control system is precision control, high level of integration, compact design, reliable fail-safe function, integrated safety function and high positioning forces.

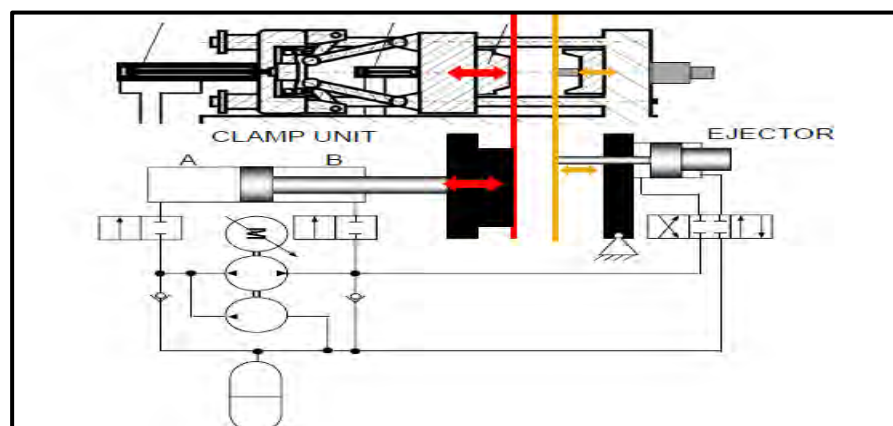

Figure 2.3: Injection Molding and Die Casting Machines [21].

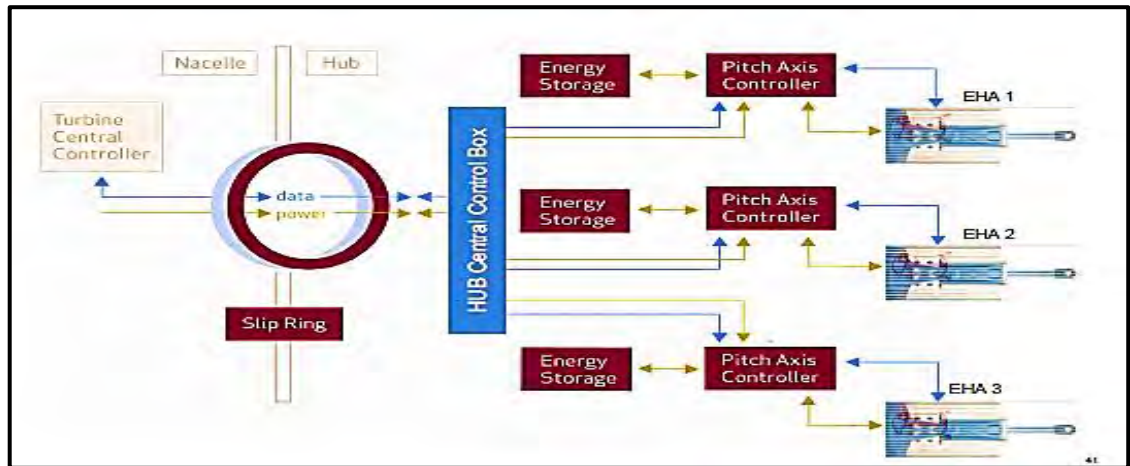

Figure 2.4: Wind turbine circuit diagram [21].

2.6 Control of EHA System.

The ability of EHA system, the system become one of the important drive system and play an important role to implement in application in industries. However, the constraints that appearing in EHA system will interrupt the application of the hydraulic control system. The internal and external disturbance that yields the nonlinearities and uncertainties in hydraulic control system. [8]. Thus, this effect will contribute disturbance of performance and degrade the system. To avoid the nonlinearities and uncertainties in EHA system, improve the control performance of EHA by designing a robust controller to compensate the nonlinear behavior of hydraulic system. Although EHA has uncertainty and nonlinearities problem, many researchers have conducted research on performance EHA, due to its advantages.

Examples of robustness controller that have been applied to EHA system have been reviewed. Many advanced control techniques have been used by researchers, but in this thesis only a few control systems will be discussed.

2.6.1 Proportional, Integral and Derivative (PID)

PID known as Proportional, Integral, and derivative or any combination controller. PID can be implemented in a wide variety of operating systems because of their functional simplicity and reliability. PID controller is designed for controlling the position of the actuator and potential to cope with physical uncertainties and external disturbances[9]. In [32] state that PID controller using tuning method are given better performance compare to conventional PID and it give good performance in term of give less overshoot and less setting time. The PID controller can be tune without approximately model .The ability of PID system can be improve the transient response of the system such as overshoot, rise time, settling time and steady error by tuning parameter PID.

$$u(t) = K_P e(t) + K_I \int_0^t e(t) dt + K_D \frac{d e(t)}{dt} \quad (2.1)$$

From the formula PID, $e(t)$ is error, $u(t)$ is the controller output and K_p , K_i and K_d are the parameter of PID based on equation (2.1). Based on Table 2.1, the comparison between K_p , K_i and K_d to the effect of controller applied on a closed loop system.

Table 2.1 Comparison between K_p , K_i and K_d

Types of controllers	Rise Time	Settling Time	Steady State Error	Overshoot, O_s
Proportional	Decrease	Small Change	Decrease	Increase
Integral	Decrease	Increase	Eliminate	Increase
Derivative	Small Change	Decrease	Small Change	Decrease

The advantage of using PID which is simple control structure that easy to understand by plant operator and found relatively easy to tune. In addition, a system using PID has proven satisfactory and also have a wide range of application in industrial control.

2.6.2 Fuzzy Logic Controller

The new approach of controller, to overcome the uncertainties and nonlinear problem the fuzzy controller were applied to EHA system. A few of research toward on fuzzy logic control has been done and utilized such as fuzzy with PID and adaptive PID control using fuzzy [17]. Jun et. al [25] presented fuzzy logic self – tuning PID controller to a nonlinear characteristic system for regulating brushless DC motor (BLDC) of EHA system. The nonlinear characteristic that occur such as saturation of the motor power and dead zone due to the statistic friction. The results show, when the Fuzzy controller implemented in EHA system, it can achieve fast response ability without overshoot. In addition, representing, manipulating and implementing a human heuristic knowledge for formal methodology can be provided to control a system performance [8].

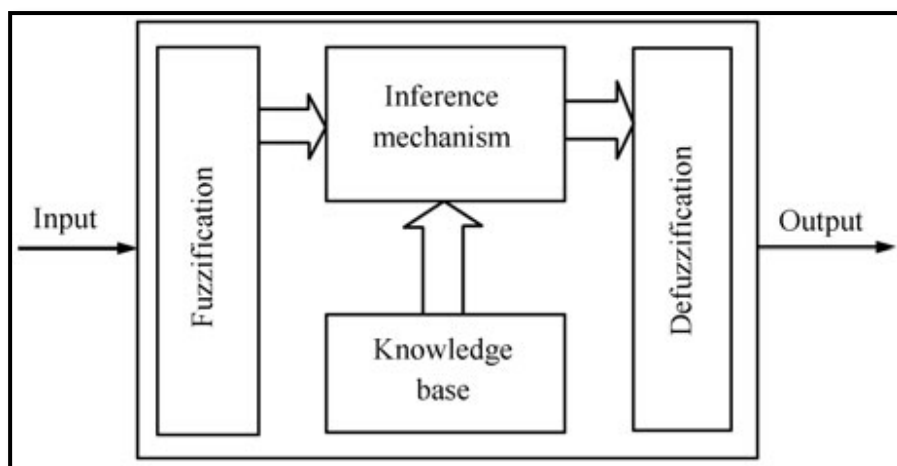

Figure 2.5: The fuzzy logic controller block diagram [8]

Four main components in fuzzy controller is Fuzzification, Inference Mechanism, Knowledge Base and Defuzzification based on Figure 2.5. The table is shown in Table 2.2 shows the every single function fuzzy logic controller block diagram.