

**CONTROL STRATEGY FOR DISTRIBUTED INTEGRATION OF PHOTOVOLTAIC
AND BATTERY ENERGY STORAGE SYSTEM IN MICRO-GRID**

MUHAMAD ASWAD BIN ZABIDE



**A report submitted in partial fulfillment of the requirement for the Bachelor Degree of
Electrical Engineering (Industrial Power)**

اونيورم تيكنيكل ماليزيا ملاك
UNIVERSITI TEKNIKAL MALAYSIA MELAKA

Faculty of Electrical Engineering

UNIVERSITI TEKNIKAL MALAYSIA MELAKA (UTeM)

2015/2016

“ I hereby declare that I have read through this report entitle “Control Strategy For Distributed Integration of Photovoltaic and Battery Energy Storage System in Micro-grid” and found that it has comply the partial fulfillment for awarding the degree of Bachelor of Electrical Engineering (Industrial Power)”

Signature :

اونيورسيتي تيكنيكل مليسيا ملاك
Supervisor's Name :

UNIVERSITI TEKNIKAL MALAYSIA MELAKA

Date :

I declare that this report entitle “*Control Strategy For Distributed Integration of Photovoltaic and Battery Energy Storage System in Micro-grid*” is the result of my own research except as cited in the references. The report has not been accepted for any degree and is not concurrently submitted in candidature of any other degree.

Signature :

اونيورسيتي تيكنيكل مليسيا ملاك
Name :

UNIVERSITI TEKNIKAL MALAYSIA MELAKA

Date :

ABSTRACT

The micro-grid deployments are growing with independently, power system designers, manufacturers and researchers for the applications where the loads are more efficient association with extra output sources such as Battery Energy Storage System (BESS), and Photovoltaic (PV) systems. Using renewable source as main sources for micro-grid system also can avoid from the pollution to occur. Energy storage when combined with PV system can provide a stronger economic performance, as well as an added benefit of backup power for critical loads. This project proposed control strategies for integration of BESS and PV in a micro-grid. The operation enables the maximum PV and BESS utilization during different operating condition of the micro-grid, grid connected, islanded mode or a process between these two operations. For this PSM (Projek Sarjana Muda), the project will focus on analyzing the performance between photovoltaic system and battery in the simulations of micro-grids system and validate the simulation result using MATLAB/SIMULINK software. After the simulation was analyzed, the understanding of benefit in using renewable energy source as main power supply with support from battery energy storage to supply the power to the loads and power managements is realized in the different modes on micro-grid which is grid connected or islanded states. When the power generation from PV system was not enough to accommodate electric loads, the BESS or from secondary side of transformer will supply the insufficient power.

ABSTRAK

Penggunaan mikrogrid semakin berkembang dengan bebas, pereka sistem kuasa, pengeluar dan penyelidik untuk aplikasi dimana penyatuan beban elektrik lebih cekap dengan sumber pengeluaran tambahan seperti sistem bateri simpanan tenaga(BESS) dan sistem fotovoltan (PV). Dengan menggunakan sumber yang boleh diperbaharui sebagai sumber utama untuk sistem mikrogrid juga boleh mengelakkan dari berlakunya pencemaran. Bateri simpanan tenaga apabila digabungkan dengan sistem PV boleh memberikan prestasi ekonomi yang lebih baik serta keuntungan tambahan dari kuasa simpanan untuk beban elektrik yang kritikal. Tujuan projek ini dilaksanakan ialah untuk strategi kawalan integrasi sistem PV dan sistem bateri simpanan tenaga di dalam operasi mikrogrid. Operasi ini membolehkan sistem PV di kadar keluaran maksimum dan penggunaan sistem bateri semasa keadaan yang berbeza sama-ada semasa disambungkan ke grid utama, mod pulau atau proses antara kedua-dua operasi. Untuk PSM ini, projek akan memberikan tumpuan kepada menganalisis prestasi sistem fotovoltan dan bateri dalam simulasi sistem mikrogrid dengan menggunakan perisian MATLAB/SIMULINK. Selepas keputusan simulasi dianalisis, pemahaman manfaat dalam menggunakan sumber tenaga yang boleh diperbaharui sebagai bekalan kuasa utama dengan sokongan daripada penyimpanan tenaga bateri untuk membekalkan kuasa kepada beban dan pengurusan kuasa disedari dalam mod mikrogrid yang telah disambungkan ke grid utama atau mod pulau. Apabila penjanaan tenaga dari sitem PV tidak mencukupi untuk menampung beban elektrik, BESS atau bahagian skunder pengubah akan membekalkan kuasa tambahan untuk menampung beban.

ACKNOWLEDGEMENT

Assalamualaikum W.B.T.

Alhamdulillah, I currently finished my final report for PSM. To begin with, i would like to express my own gratitude to Allah The Almighty for giving me the health and strength to complete my Projek Sarjana Muda successfully. I would like to show my special thanks for both my parents for their continuous support and help in order to complete my research. I would also like to express my deepest gratefulness and thank to my supervisor, En. Alias bin Khamis who willing to spare his time in guiding and share his experience for me to complete this research. I would also like to thank all my friends who have support and willing to help me in completing the research and the report. Finally, I would like to thank the entire member in matlab forums for all their help for teaching me and completing this project and once again, I wish to express my thanks to all those involved, either directly or in directly.

TABLE OF CONTENTS

CHAPTER	TITLE	PAGE
	ABSTRACT	i
	ACKNOWLEDGEMENT	iii
	TABLE OF CONTENTS	iv
	LIST OF TABLES	vi
	LIST OF FIGURES	vii
	LIST OF ABBREVIATIONS	viii
	LIST OF APPENDICES	ix
1	INTRODUCTION	1
	1.1 Research Background	1
	1.2 Problem Statement	2
	1.3 Objectives	2
	1.4 Scope	2
	1.5 Structure of Report	3
2	LITERATURE REVIEW	4
	2.1 Introduction	4
	2.2 Micro-grids	4
	2.3 Photovoltaic System	5
	2.3.1 PV Array Model	6
	2.3.2 MPPT Control Algorithm	7
	2.4 Battery Energy Storage System	9
	2.4.1 PV Output Smoothing with Energy Storage	10

2.4.2	Control of BESS in Microgrids for Islanded Mode	10
2.5	Review of Previous Related Works	11
2.6	Summary	12
3	METHODOLOGY	13
3.1	Introduction	13
3.2	Flow Chart of Methodology	15
3.3	System Configuration and Operation	15
3.4	Summary	20
4	RESULTS AND DISCUSSION	21
4.1	Introduction	21
4.2	Simulation Result	21
4.3	Analysis of the Simulation Result	23
4.4	Cost Calculation	29
4.5	Summary	30
	CONCLUSION AND RECOMMENDATION	31
5.1	Conclusion	31
5.2	Recommendation	31
	REFERENCES	32
	APPENDIX	35

LIST OF TABLES

TABLE	TITLE	PAGE
3.1	The operating modes for micro-grid.	19
4.1	Table 4.1 The cost of power usage	30



LIST OF FIGURES

FIGURE	TITLE	PAGE
2.1	The Microgrids system with source and Connection or interconnection directly from local grid.	5
2.2	The component of Photovoltaic system.	6
2.3	The model for equivalent circuit of a photovoltaic cell	7
2.4	Solar Powered System Model.	8
2.5	Overall configuration of fuzzy logic controller.	11
3.1	Flow chart of Methodology from beginning of project until submit the report.	14
3.2	The studied micro-grid layout for integration of PV and BES.	15
3.3	The simulation circuit of micro-grid system using MATLAB/SIMULINK software.	16
3.4	The PV system output data using 1-D lookup table	17
3.5	The data of total power for each load using 1-D lookup table	18
3.6	The structure of battery controller	19
4.1	The micro-grid system overall operation result	23
4.2	The comparison when only battery as power supply.	24
4.3	The comparison when PV system have partial shading condition	25
4.4	The SOC plot when in charging state	26
4.5	The comparison of powers when battery in charging state	27
4.6	The percentage of SOC	28
4.7	The comparison when SOC in off state	28
4.8	The comparison powers	29
4.9	The comparison powers	30

LIST OF ABBREVIATIONS

AC	-	Alternating Current
BESS	-	Battery Energy Storage System
DC	-	Direct Current
I_d	-	Diode current in the equivalent circuit of PV cell
I_i	-	Terminal current of the ideal PV module
I_o	-	Diode reverse saturation current
I_p	-	Shunt current across the p-n junction (A)
I_{ph}	-	Photocurrent (A)
i_{pv} , v_{pv}	-	PV output current and voltage
K	-	Polarization voltage
K	-	Boltzmann's constant
PV	-	Photovoltaic
MPPT	-	Maximum power point tracking
MPP	-	Maximum power point
M_s	-	Number of series connected PV cells in a PV module
N_p	-	Number of parallel-connected PV cells
N_s	-	Number of series connected PV cells
P_{pv}	-	PV system output power
PWM	-	Pulse-width modulation
Q	-	Electron charge
RES	-	Renewable system energy.
R_p	-	Resistance connected in parallel (Ω)
R_p	-	Parallel resistance modeling the leakage current a Diode
R_s	-	Resistance connected in series (Ω)
R_s	-	Series resistance representing the structural resistances
V_d	-	Diode voltage (V)
V_{pv}	-	Voltage output from PV system.
W	-	Watt
%	-	percent

LIST OF APPENDICES

APPENDIX	TITLE	PAGE
A	The simulation of micro-grid	35
B1	Solar Data 1-D Lookup Table	36
B2	Load Data 1-D Lookup Table	37
C	The data of simulation micro-grid system	38
D	The comparison of data using simulation data inspector	39



CHAPTER 1

INTRODUCTION

1.1 Research Background

Renewable energy rise as an alternative energy that will not run out and can prevent pollution from occurring. Many researchers became interested in the field of power system from current conventional power system which has been long used into smart grids involving micro-grids [1].

The technologies for renewable energy source such as photovoltaic and wind have a fast development uses in integration grid to less the operational cost for loads in using the energy either to generate a DC or an AC power source [2].

Microgrids increase dependability locally through the establishment of a reliability development plan that integrates redundant distribution, smart switches, power generation and energy storage. Local power generation and storage let portions of the grid and critical facilities to function independent of the larger grid when needed and thus eliminate blackouts.

The engagement of PV generation and energy storage system use in micro-grid system get more attention between researchers for studying in micro-grid system. In grid integration, PV supposed to work in Maximum Power Point Tracking (MPPT) to supply the accessible power and the Battery Energy Storage System (BESS) necessary to deliver the difference power in case the PV system did not meet the requirement of total load. The main grid is likely to support the balance of power and regulate the voltage.

1.2 Problem Statement

In micro-grid system, the customer demanding domestic and industrial is all about the lesser operational cost and electrical energy uses. Other than that, conventional distribution networks that accept distributed generation connections may face serious difficulty when its control and protection functions become more complicated. This incurs a burden to the network operation and some technical limitations will appear when a great number of distributed generations are installed [3]. A normal power system usually full supported from main grid power for a factory or house to operate. To avoid this problem, the research about the benefit and performance of PV system and battery energy storage micro-grid must be finding and new innovation must be made to settle the problem.

1.3 Objectives

The following are the objectives of this project:

1. To study the control strategy for distributed integration of Photovoltaic and Battery Energy Storage System in micro-grids.
2. To analyze the power management between Photovoltaic system and battery in the simulations of micro-grids system in grid connected or islanded mode.

1.4 Scopes

The scopes of this project are:

1. To study the strategy for distributed integration of Photovoltaic and Battery Energy Storage System in the micro-grid system.
2. To analyze the power management of the micro-grid in grid connected or islanded mode using MATLAB/SIMULINK software.

1.5 Structure of Report

In this report, there are five chapters that will be explaining the details of this project. Firstly, all about the introduction of this project consist of project background, problem statement, objectives and scope are covered in first chapter. For chapter two, the literature review on former researches about micro-grids, photovoltaic system and battery energy storage are included. Next, the methodology of this project will be illustrated using flow chart, methodology in details is in chapter three. For chapter four, the analysis of the data which is obtain from the simulation result and discussion of the result will be verified and discussed. Finally, the finding that was concluded from final result in chapter 5.



CHAPTER 2

LITERATURE REVIEW

2.1 Introduction

This chapter focuses on the overall project theory as well as the concept. The aim of this section is to discuss the theory and process which is used in past or recent project. On top of that, this chapter will bring on the idea and theory used to solve the project problem. Theoretical is essential for a guide during doing in any of study or research

2.2 Micro-grids

Micro-grid that is a local grid which can connect and disconnect from the conventional grid to function autonomously and also help minimize the grid disturbances to reinforce the grid resiliences. In micro-grids which are low-voltage AC grids, often use diesel generators, and are installed by the community. It also can become as an essential purpose in changing the local electricity grid system. The different between traditional electricity grid (macro-grid) and micro-grid is the scale of the grids. Micro-grid is more like a small-scale grids compare to macro-grids. Micro-grids utilize with combination of the different energy resources, such as solar hybrid or using smart wind turbine power systems which can decrease the cause of the pollution [4].

Micro-grids can supply the thermal and electricity power plus supporting and reducing the voltage sag will improve the quality of the power. From the utility's perspective, utilization of distributed energy sources can likely lower the appeal for distribution and

transmission facilities. The loads will decrease the flows in transmission and circuit of distribution with important effect which is capability to possibly substitute for network assets if distributed generation positioned close to loads. Furthermore, the service quality will be increased if the existences of the generation meet the demand of the customers. By reducing congestion and aiding restoration after faults, micro-grids can deliver the network support in times of stress. The mitigation of climate changes and the decreasing of emissions may be provided by development of micro-grids. This is because existing and emerging technologies for distributed generation units derived from renewable sources and micro source that are categorized by very low emissions.

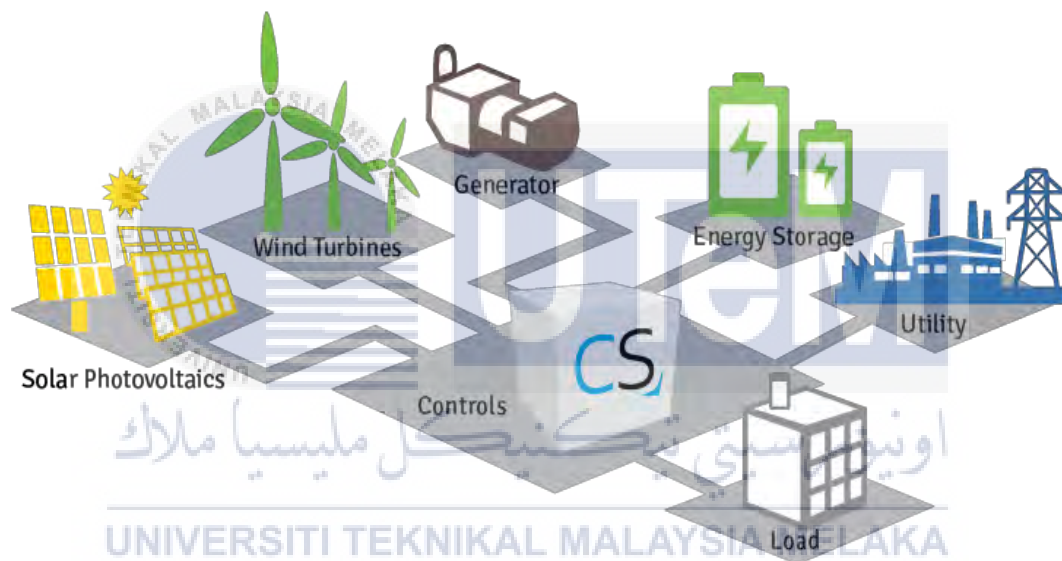

Figure 2.1 : The Microgrids system with variable source and connection or interconnection directly from local electricity grid.

2.3 Photovoltaic System

Solar photovoltaic is the method where the electricity formed from sunlight radiation. A semi conducting materials are used to make the photovoltaic cell where the sunlight strikes the cells, it is transformed into electricity. The solar cells are constructed from some thin layers of silicon. The electrons inside the cell are knocked loose when the PV panels were

strikes by sunlight radiation. The negative electron gets pushed away from silicon atom by the immersion of photon and positive hole remains. The positive hole and the unbound electron together are neutral.

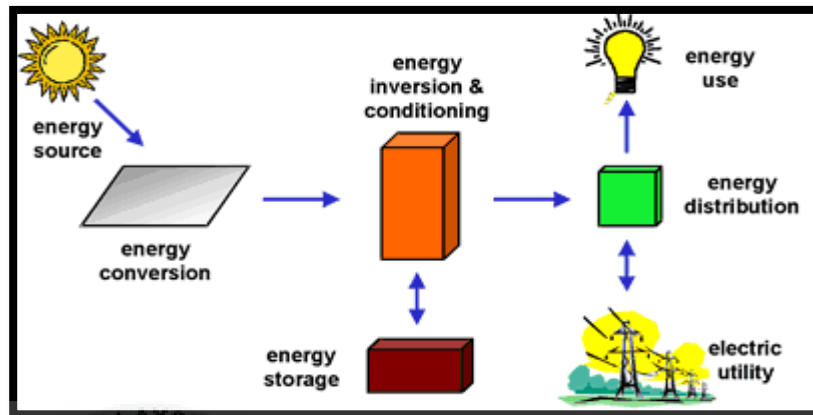

Figure 2.2 : The component of Photovoltaic system

So, the greater the solar radiation, the flow of electricity will become much more. The electricity was produce and delivered to energy distribution station thus to load or utility as shown in Figure 2.2.

2.3.1 Photovoltaic Array Model

Photovoltaic cells contains of p-n junction made up in a thin layer of semiconductor. Monocrystalline and polycrystalline are the common material for PV cells. The ideal solar cell is the one in which a current supply is connected in antiparallel with a diode. When the cell is exposed to sunlight, the direct current generated which varies linearly with solar radiation. The model can be improved, including the effect of a shunt resistance and series resistance. The single-diode model for PV cells equivalent circuit is presented in Figure 2.2.

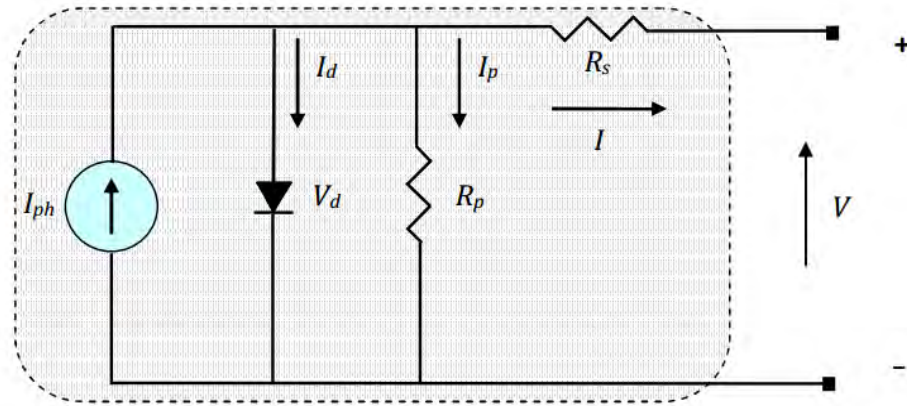

Figure 2.3 : The model for equivalent circuit of a photovoltaic cell

2.3.2 Maximum Power Point Tracking Control Algorithm

A maximum power point tracker is an electronic DC to DC converter that optimizes the match between PV panels and the battery storage or conventional grid to maximize the output power [13].

The solar radiation and temperature have an impact on the output power characteristic of the photovoltaic system where the purpose of irradiance and temperature curves are nonlinear. Moreover, during the day, the solar radiation has unexpected variation. For these circumstances, the photovoltaic systems operating point need to shift to maximize the generated energy when the maximum power point of the photovoltaic shifts continuously. Thus, to maintain the photovoltaic array's operating point at its maximum power point, the maximum power point tracking techniques was used.

2.3.2.1 Constant Voltage Method

A constant voltage method is the steady voltage of MPP algorithm that spontaneously regulated the reference voltage for unpredictable environmental conditions. The concept of this method was shown in Figure 2.4. A simple analog feed forward pulsewidth modulation

controller is creating as the weather conditions differ to track the maximum power point of a solar cell array. The open circuit voltage is tested while not busting the entire source from the load since the circumstance with other constant voltage MPPT methods was configured by solar array source [16].

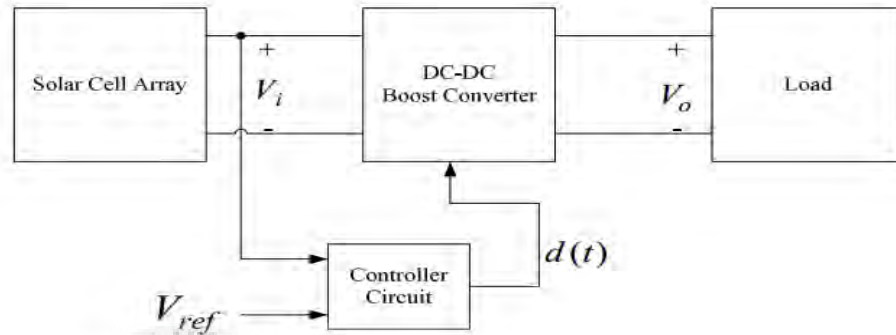

Figure 2.4 : Solar Powered System Model.

2.3.2.2 Incremental Conductance Methods

Based on the observation that using formula holds at the MPPT for incremental conductance methods [18];

$$\left(\frac{dI_{PV}}{dV_{PV}} \right) + \left(\frac{I_{PV}}{V_{PV}} \right) = 0 \tag{eq. 2.1}$$

where I_{PV} and V_{PV} are the PV array current and voltage, respectively.

When the ideal operating point in the P-V plane would be to the right of the MPP, we have $(dI_{PV}/dV_{PV}) + (I_{PV}/V_{PV}) < 0$, while the ideal operating would be to the left of the maximum power point, we have $(dI_{PV}/dV_{PV}) + (I_{PV}/V_{PV}) > 0$. The maximum power point will be followed by differentiating the immediate conductance (I_{PV}/V_{PV}) to incremental conductance (dI_{PV}/dV_{PV}) . Hence the mark of the quantity $(dI_{PV}/dV_{PV}) + (I_{PV}/V_{PV})$ shows

the appropriate direction of perturbation causing to the MPPT. The operation of photovoltaic array is retain at this point and the perturbation ended unless a change in dIPV is noted once maximum power point was achieve. In this instance, the algorithm decrement or increment of V_{ref} to track the new maximum power point [18].

When the MPPT has been achieved, it is theoretically likely to discover when the perturbation can be stopped by the incremental algorithm. The incremental algorithm provides a great performance under quickly shifting atmospheric conditions.

The advantages for incremental conductance techniques are the efficiency is high which is about 98% and the reliability is accurate. While for disadvantages, the design complexity is more difficult. The cost for this design also expensive and more complex compare to other technique [19].

2.4 Battery Energy Storage System

Energy storage can provide much more versatility as well as balancing to the grid, offering an important backup in order to intermittent renewable energy. It may enhance the controlling regarding to distribution networks, increasing efficiency and reducing the cost. By doing this, it could convenience the market benefit of renewable energy, ensuring higher security for energy supply, speed up the decarbonization of utility grid, and also enhance the protection and efficiency for transmission and distribution of electricity.

For distribution area, BESS can regulate the electricity source from variable renewable energy sources to the low or medium voltage of utility grid to match up with load demand. This also happen by managing the power flow and keeping voltage in suitable range and mitigating blockage.

2.4.1 Photovoltaic Output Smoothing with Energy Storage

The battery was functional as to increase the power to the photovoltaic output or decrease which is to smooth out the excessive frequency of the photovoltaic power that happen through interval with passing cloud shadows over the photovoltaic panels. While preventing overworking the electrical battery when it comes to capacity and ramp functionality, the control system is pushed with the challenge to decreasing temporary photovoltaic output variability. The control framework provides two extra inputs in order for battery to respond. For instance, the actual battery might react to photovoltaic variability, load variability or area control error or a mix of the three [6].

The system parameter supposed to be fixed photovoltaic system rating, the rating of converters and size of the battery capacity. A modify in the nominal parameter values needed to generate continued adequate overall performance should be effected with different battery parameter values. The result of temperature, charge or discharge rating, equalization and efficiency charging wasn't regarded. This kind of improvement might be included into the model. However, their effect on the entire controller functionality is just not likely to be very considerate [6].

UNIVERSITI TEKNIKAL MALAYSIA MELAKA

2.4.2 Control of BESS in Microgrids for Islanded Operation.

The actual microgrids works in grid connected mode, however when fault happen in the upstream grid, it will detach as well as change into islanded mode. For grid connected mode, the managing power at the point of common coupling is essential management operation as opposed to the frequency and voltage. The harmonized control strategy involving diesel generator and battery energy storage system is required for the controlling the frequency and voltage when inquired in islanded mode. Almost all Plus Integral Controller (PIC) own set Plus Integral (PI) gains however, real time current gains are usually applied to PI controller applying Fuzzy logic. Therefore, output feature of battery energy storage system utilized real

time current gains to PI controller by applying fuzzy logic is quicker and much more precise than using fixed gains [7].

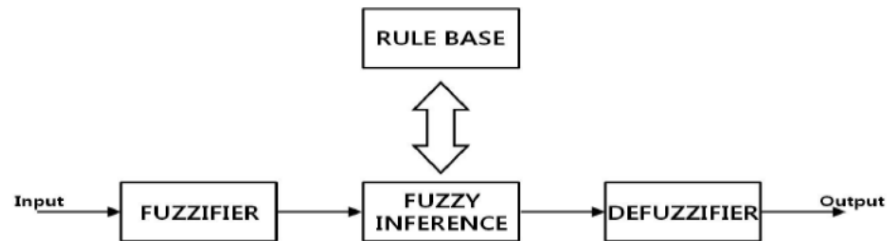

Figure 2.5 : Overall configuration of fuzzy logic controller.

Fuzzy logic offers strength to nonlinear design evaluation as well as don't have to use mathematical model when comparing to general PI controller. Therefore, utilizing Fuzzy PI controller at battery energy battery storage system will be much more precise and faster than PI controller at battery energy storage system. Beside to robustness is much more outstanding than PI controller [7]

2.5 Review of Previous Related Works

The management strategy for distributed regarding of renewable sources as backup sources in micro-grids was study by Amjad Anvari Moghaddam, Alireza Seifi from Department of Power & Control, School of Electrical and Computer engineering, Shiraz University, Taher Niknam from Department of Electrical and Electronics Engineering, Shiraz University of Technology and Mohammad Reza Alizadeh Pahlavani from the Department of Electrical Engineering, Iran University of Science Technology (IUST), Tehran. Their paper proposes for optimal operation of a typical micro-grid with RES accompanied by a back-up Micro-Turbine/Fuel Cell/Battery hybrid power source to level the power mismatch or to store the surplus of energy when it's needed. The suggested management allows the maximum renewable energy use through various operating modes of the system where grid is connected

to micro-grids, islanded mode or changeover among both modes while generating an allowance for the direct current voltage control and loads source [17].

There also a researches using four type of renewable energy source (RES) which is wind turbine, fuel cell, PV and energy storage (ES) in micro-grids system. The function of an isolated direct current micro-grid that involves of the turbine of wind, ES, PV system and direct current loads was researched which is to integrate the alternating current supply with other RES and the controller can be designed for an effective power management that will be used as hybrid power supply with utilization of green energy than conventional grid energy [22].

2.6 Summary

This chapter discuss on the overall project theory and concept. The purpose of this is to explain the perspective and method that is used in previous research or projects and to classify how much this project relate with those research and theory. Moreover, this chapter will show the theory and concept used to solve the project problem. Theoretical is very important as a guide in doing any kind of research. This chapter provided to six subtopic. First, it was about the details of micro-grid then follow by a PV system. Then, there's about BESS follow by the review of previous related works.

CHAPTER 3

METHODOLOGY

3.1 Introduction

The research strategy is inevitable to obtain a great result in study and solving the problem. In order to study the data effectively, it's really essential to acquire the best understanding and also seeing regarding the flow strategy of the statistical solution to be used. Through this chapter, the process flow will be presented to indicate the experimental procedure of the project. After that, it is pursued by much more details in the assessment of factors of defect design by utilizing the flow chart of methodology for this project. The strategies are concentrate on the actual factorial design experimental which have been choose this specific task and also already been research in Literature review. For methodology section, the chapter will concentrating on the process that been done to achieved the objective and fulfill the research target in Chapter 1, which is to study the management strategy for distributed regarding of PV and energy storage in micro-grids, to design the PV system and BESS.

3.2 Flow Chart of Methodology

The methodology is planned by using the flow chart for conveying the method from the beginning until the end of the project. The task that carried out will be more systematics and acceptable using the flow charts. By following the flow charts, any mistake or problem will be easy to locate and solve. For this research, the corresponding flow charts are organized will be displayed in Figure 3.1.

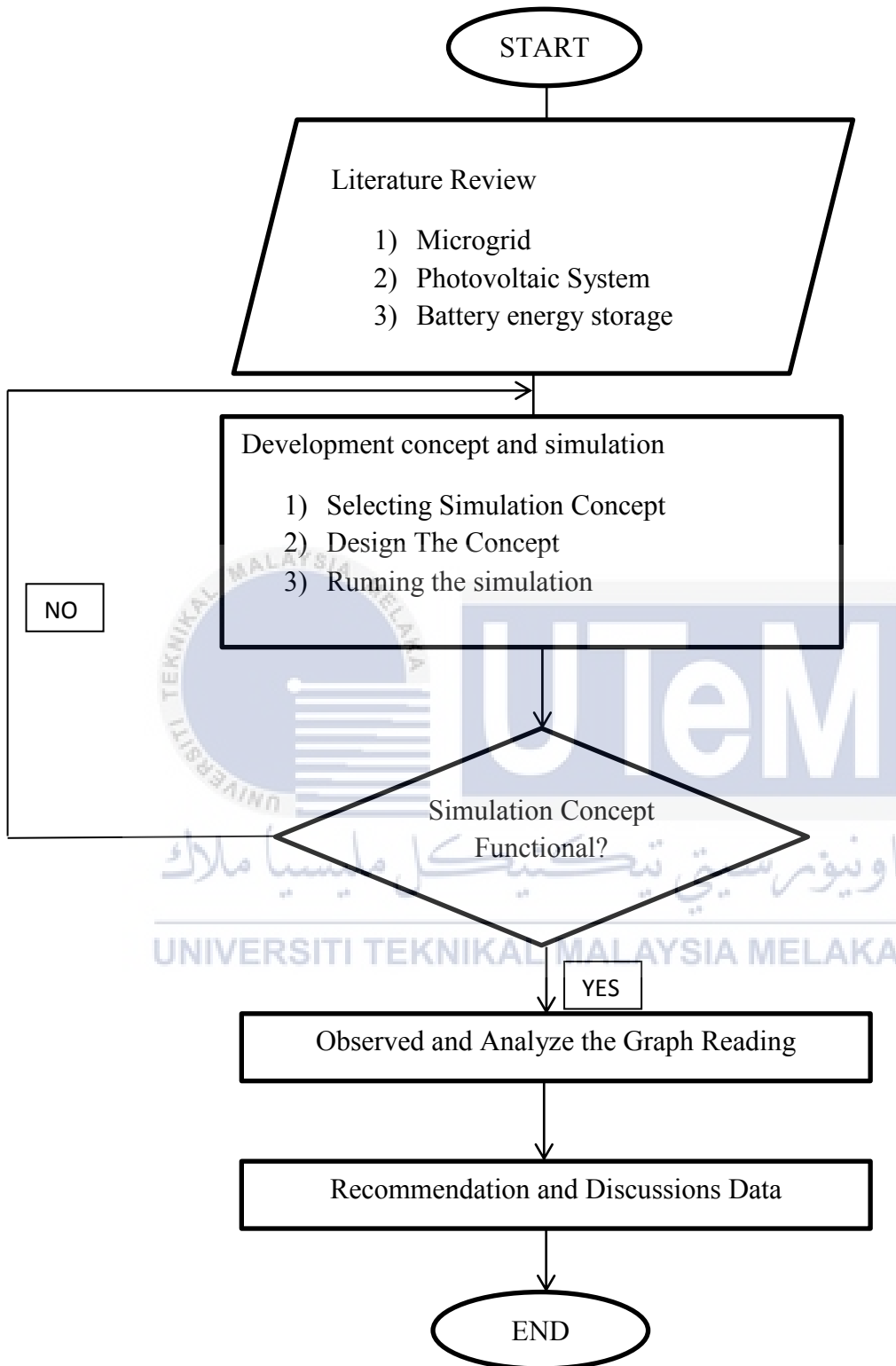

Figure 3.1 : Flow chart of Methodology from beginning of project until submit the report.

In the literature review section, the first step was to find the essential information about the main part of the projects which is the micro-grid, the PV system and the BESS. Then, by using the information's from the literature review, the concept of simulation of the project was designed. If the simulation was functional correctly and the result was reliable, then the data will be observed and analyzed. Finally, the discussion of the result was discussed and the recommendation was established.

3.3 System Configuration and Operation.

3.3.1 The micro-grid structure.

The micro-grid design is shown in Figure 3.2. The micro-grid systems are made up of PV system connected through battery energy storage and three of loads. The primary source for this system is PV system which is to operate at MPPT. The BESS is use to balance the difference in power between the PV power system and load demand in islanding mode. The simulation of the micro-grid system will be designed using MATLAB/SIMULINK software as shown in Figure 3.3. The duration for simulation to be running was 86400 second (24 hour).

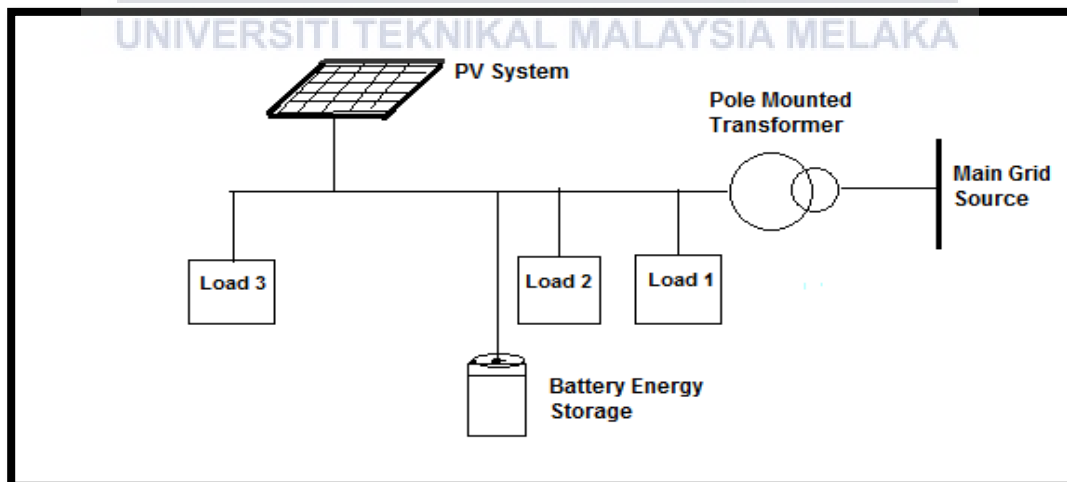

Figure 3.2 : The studied micro-grid layout for integration of PV and BESS.

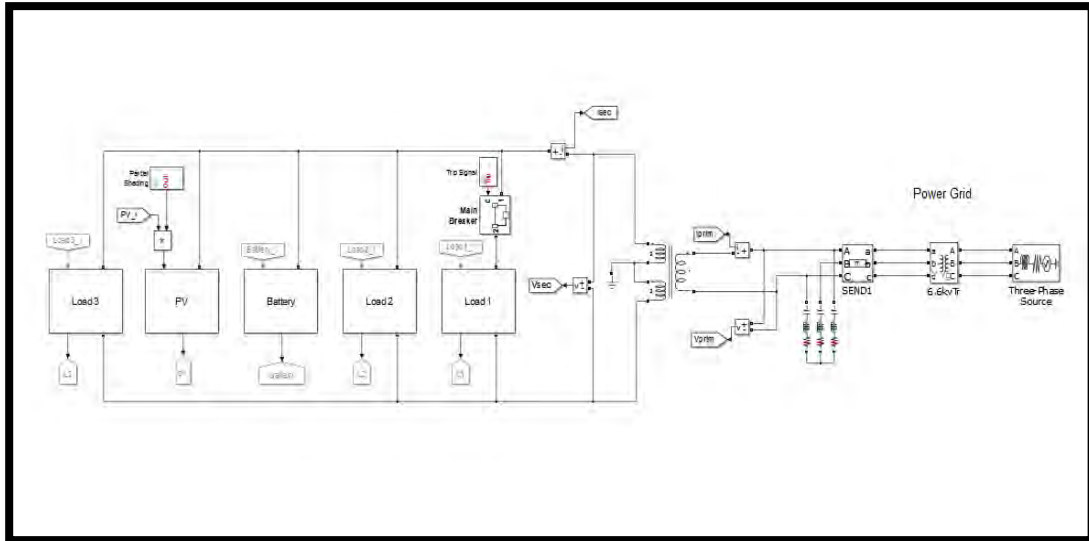

Figure 3.3 The simulation circuit of micro-grid system using MATLAB/SIMULINK software.

3.3.1.1 Photovoltaic System

Solar photovoltaic is the method where the electricity formed from sunlight radiation. In the simulation, the total power output for PV was set by using 1-D lookup table and the example was shown in Figure 3.4 which is from 401 minute to 412 minute. As example, the output of PV system at 401 minute was 1250W. The maximum power can be generate by PV system was 5kW.

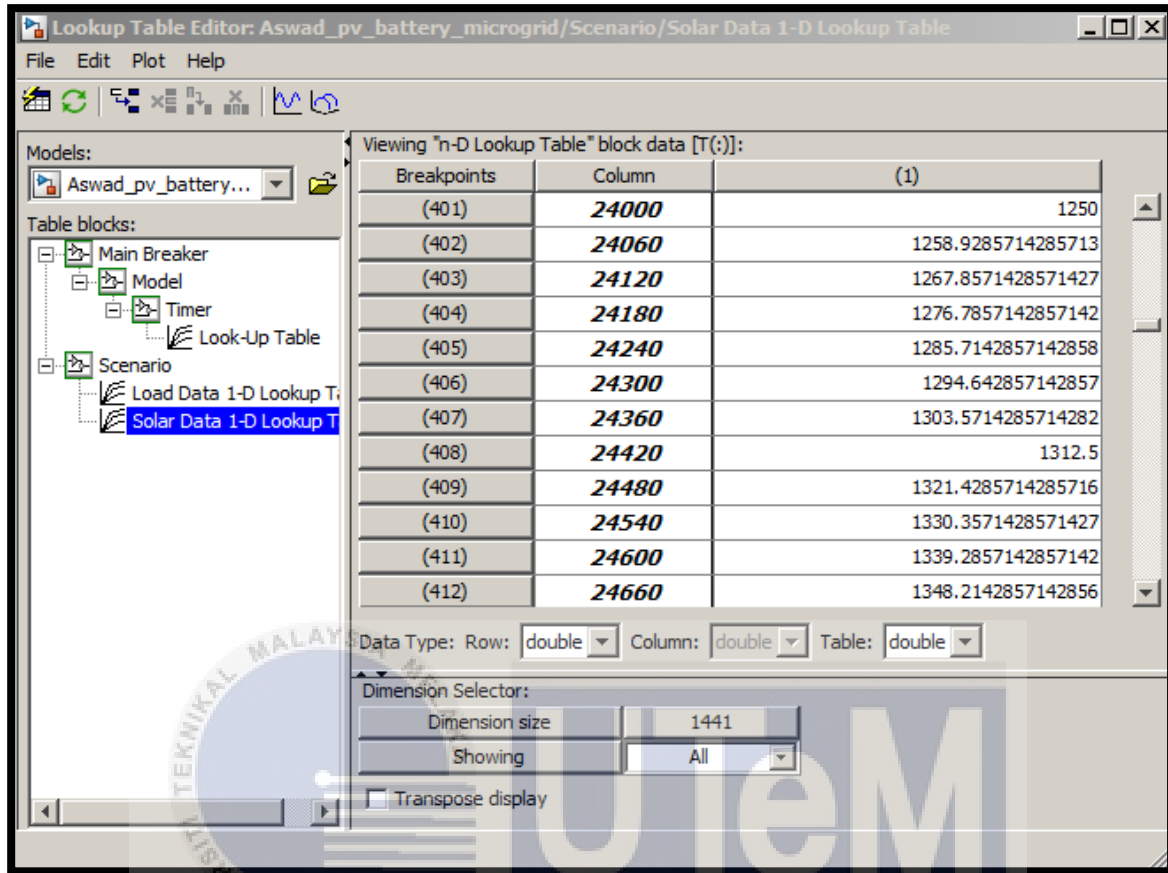

Figure 3.4 The PV system output data using 1-D lookup table.

3.3.1.2 The Loads in the Simulation.

In the micro-grid system simulation, there are three of loads of the system. The loads can compare as a house or factory in the micro-grid system. In the simulation, the total power for each load was set by using 1-D lookup table and some of loads data was shown in Figure 3.5 which is from 585 minute to 596 minute. As shown in Figure 3.5, at 592 minute the total power need by load was 1312.5W. The maximum power need for each load was 2.5kW. The condition for power needs by each loads are same. At load 3, there's a circuit breaker that will activate at 28800s (8.00am).

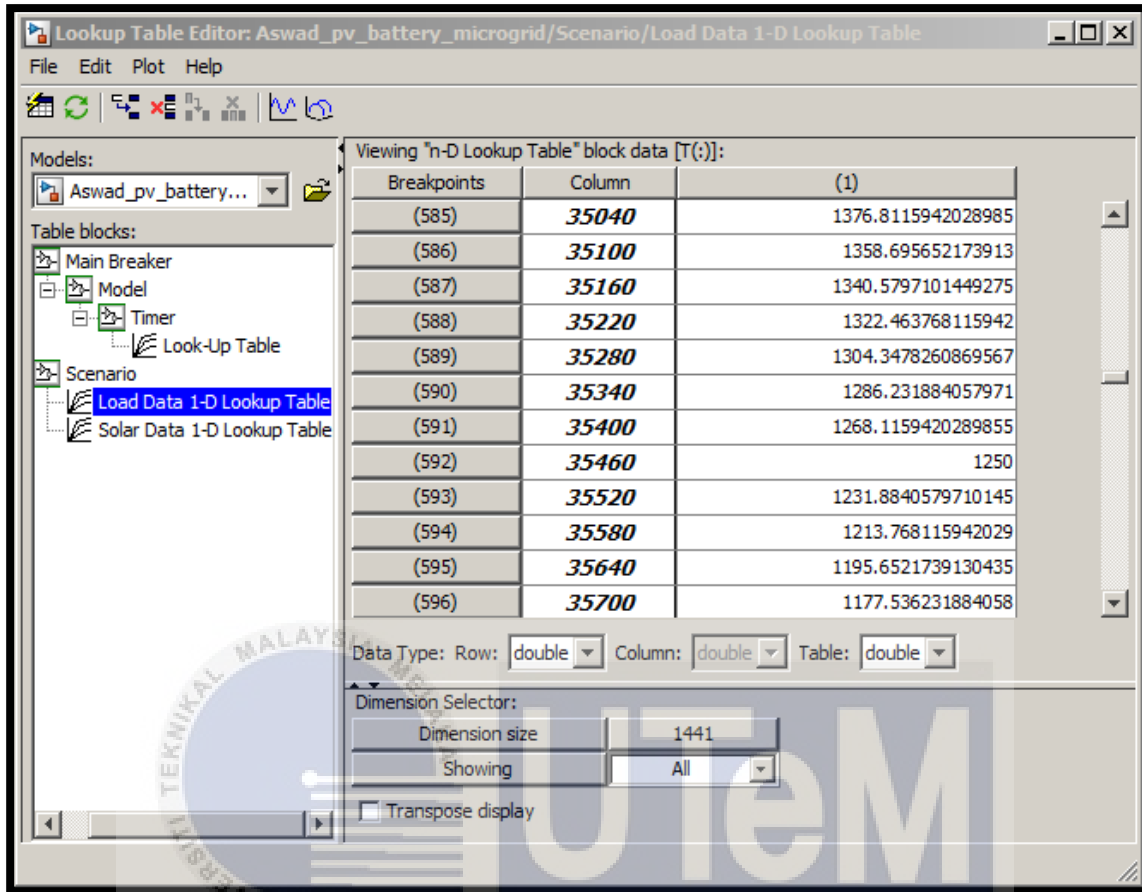

Figure 3.5 The data of total power for each load using 1-D lookup table.

3.3.1.3 Modeling of Battery Energy Storage System.

The model of the battery used in the simulation are examples from MATLAB/SIMULINK software which call battery simple dynamic where the capacity of the battery was 1000Ah and the rating was 150V, 30A/h which means the maximum power generated by battery was 4.5kW.

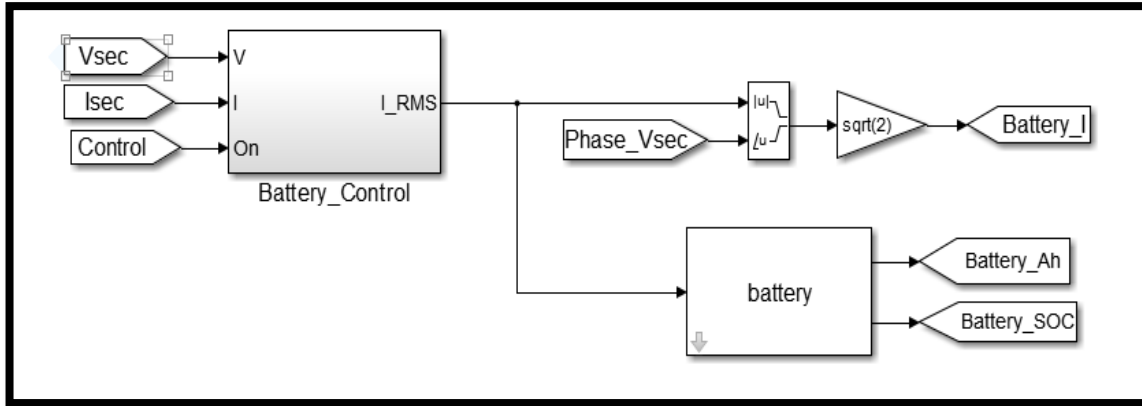

Figure 3.6 The structure of battery controller.

The battery control is performed by battery controller. The system performs by tracking control of the current which means that the active power which flows into power system from the secondary side of the pole mounted transformer is set to 0. Thus, the active power for secondary side of the pole mounted transformer is continuously around zero. When the battery controller is performed, the micro-grid system was in islanded mode. The structure of battery controller was shown in Figure 3.6. In the simulation, the battery control performs from 0s (12.00am) to 43200s (12.00pm) and 64800s (6.00pm) to 86400s (12.00am).

3.3.2 Operating modes of grid.

The system must run with connected to the utility grid or islanding mode where the battery controller was performed. The management of the system has to control the bus voltage in different operating modes. The different modes are described in table 3.1.

Table 3.1 : The operating modes for micro-grid.

Mode	Main grid state	PV condition	Condition of Battery
1	supply	MPPT	Charging/off
2	receive	MPPT	Charging/off
3	off	MPPT	Discharging/off
4	off	MPPT	Charging/off
5	receive	OFF MPPT	Off

In mode 1, the main grid is connecting to micro-grids and operating high load condition which is the PV is working in maximum power point and energy storage charging or off state. In mode 2, this usually happen when low load process. The PV and BESS are in the same state in mode 1 but the main grid will deliver the power when the power is insufficient.

Operating mode 3 and 4 is occur during islanding state of the micro-grid where PV is working in MPPT and the BESS will charging or discharging for balancing the insufficient power. For mode 5, the BESS is fully charged in islanded micro-grid and the power need for load is less than maximum power of PV system.

After the simulation, the results are recorded in graphical method and the analysis of the result will be discussed in Chapter 4.

3.4 Summary

This chapter discuss on the overall project methodology. The purpose of this is to explain the method that is used throughout the research. Moreover, this chapter also introduced the method and concept used to solve the project problem.

CHAPTER 4

RESULT AND DISCUSSION

4.1 Introduction

This chapter contents of result and discussion of the effect concept to output energy and efficiency from solar panel and the analysis of the micro-grid performances. The result was presented in table and graphical method.

4.2 Simulation Result

4.2.1 The Micro-grid system

The main power sources for this micro-grids system are photovoltaic system and battery energy storage. The PV system maximum power generate at 5kW as RES. The power source for this micro-grid was a PV system, from main grid and battery energy storage. The battery rating was 150V, 30 A/h which is maximum power for the battery storage to deliver was 4.5kW and the capacity of the battery was 1000Ah. If there's surpluses power in micro grid, the battery controller will deliver to battery storage or deliver to loads if there's insufficient power. When the battery controller is performed, there's no power from the secondary side of the transformer. The Figure 3.3 shows the simulation circuit of the ideal micro-grid. Figure 4.1 show the general result of power management of micro-grid in 24 hour duration.

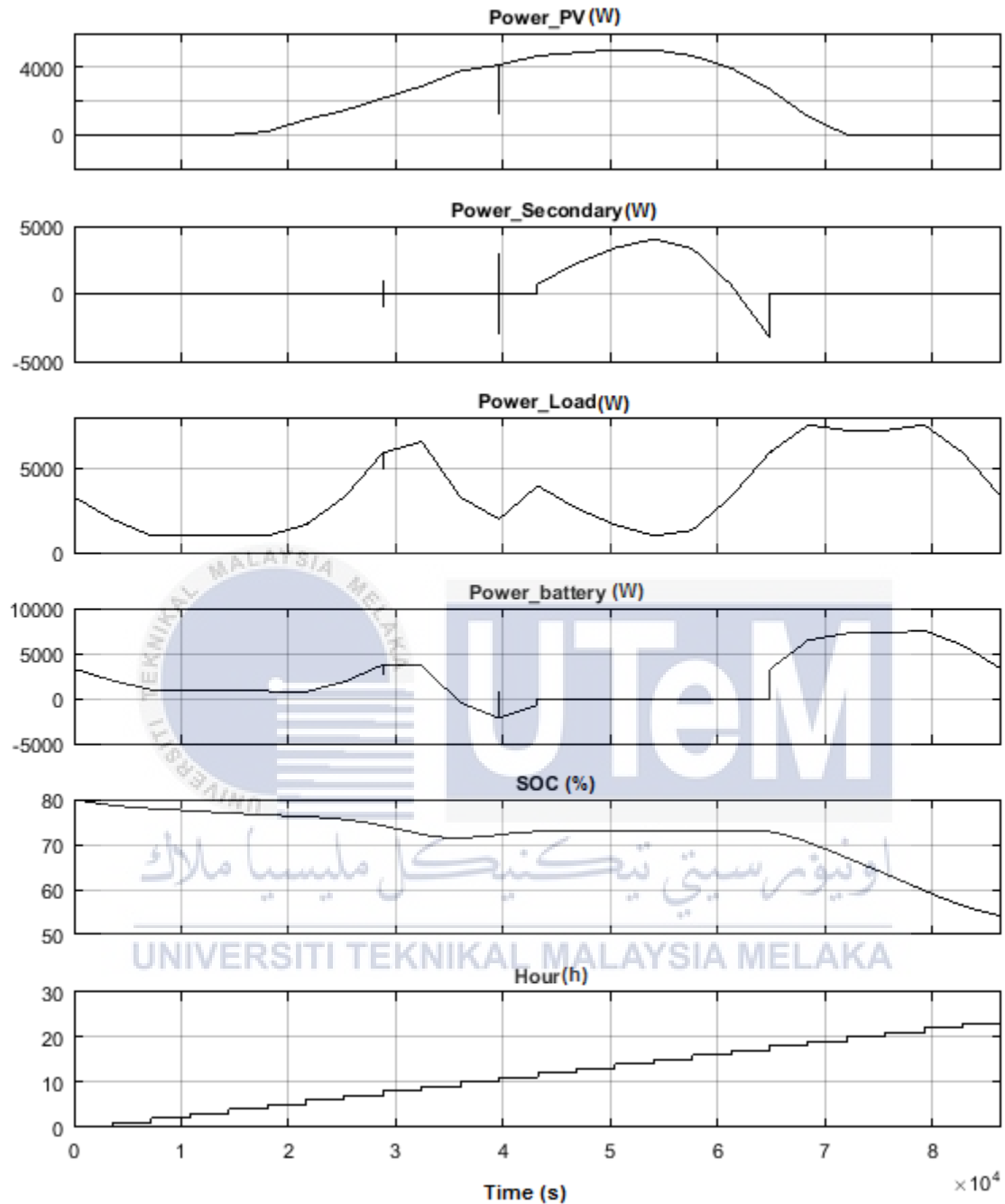

Figure 4.1 The micro-grid system operation, (a) PV Power (W), (b) Secondary side power (W), (c) Load power (W), (d) Battery Power (W), (e) State of Charge (%), (f) Time (s) in 24 hour durations.

The maximum power for loads to consume as electric loads was 7.5kW. Each load has 2.5kW maximum power demand. The micro-grid is connected to the system power via a pole-mounted transformer. The solar power generation and the storage battery are DC power sources converted into single-phase AC. These are both connected to the micro-grid. It is assumed that in control strategy, the micro-grid does not depend on system power for power consumption, and required power is provided by solar power generation and the storage to the extent possible. The analysis of the system will be discussed in the next sub topic.

4.3 Analysis of the simulation result.

From the simulation result, there are six situations that happen when the simulation was running. In each situation, it describes the power management between PV system, BESS and power from the secondary side of the transformer to the load. If the power generation from PV system was not enough to accommodate electric loads, the BESS or from secondary side of transformer will supply the insufficient power. It also happen in two conditions which is the micro-grid system was connected to the grid or in islanded mode.

4.3.1 Situation 1.

In this situation which is from 8.00pm until 4.00am, the PV power generation is 0W. This happen because there's not have sunlight ray for PV system to convert to electrical energy. As shown in Figure 4.2 which is from 0s (12.00am) until 14400s (4.00am) , the peak power of loads was 3325W which fully supplied by battery storage power because the PV system was not active and the battery controller was performed which is this situation is in islanded mode thus power from secondary side of the transformer is 0W.

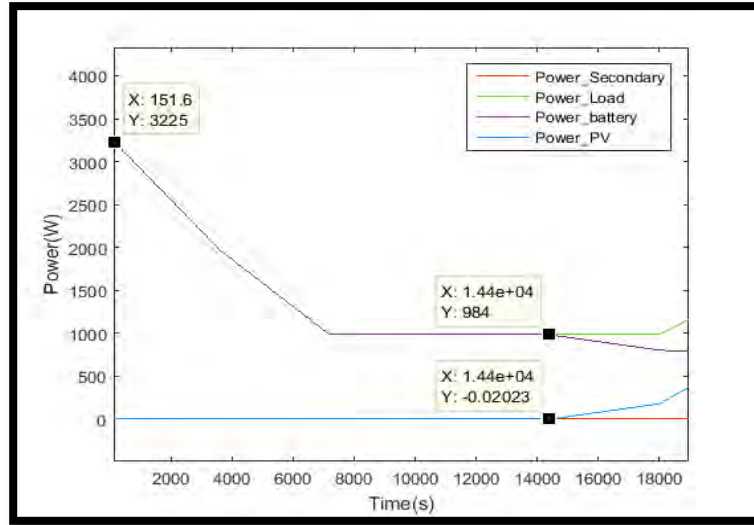

Figure 4.2 The comparison between power (W) of Load, PV, battery storage and secondary side of transformer when only battery as power supply

4.3.2 Situation 2

At 39600s (11.00am) as shown in the Figure 4.3, the graph line for power of PV suddenly change and also the battery.

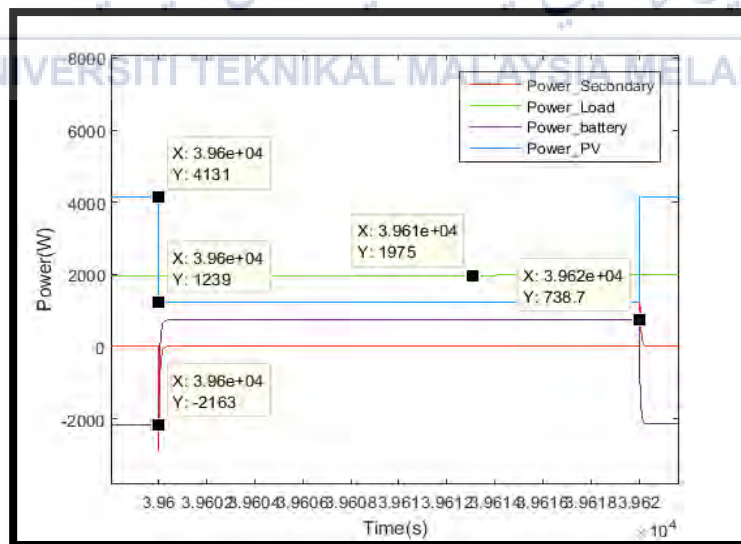

Figure 4.3 The comparison of the total powers when the PV system have a partial shading condition.

The solar panel of PV system has partial shading which is leading to the maximum power of the PV system suddenly decreases in 20 second duration from 4131W to 1239W. While this happen, the battery energy storage supply the insufficient power 738.7W to the loads. After 20 second duration, the PV system back to normal state. The battery will support the PV as backup in deliver the insufficient power for loads. The micro-grid in mode 5 then change to mode 3.

4.3.3 Situation 3

For this situation, the Figure 4.4 shows that the State Of Charge of the battery storage was increased from 71.47% to 72.85%. This happen because the surpluses power from PV system delivered to battery storage (charging) .The surpluses power did not deliver to main grid because of the battery controller that was already performed which is from 6.00pm until 12.00pm at the primary side the current was set to zero (as the micro-grid was disconnected from main grid / islanded state). This situation happen as in mode 4 of the micro-grid.

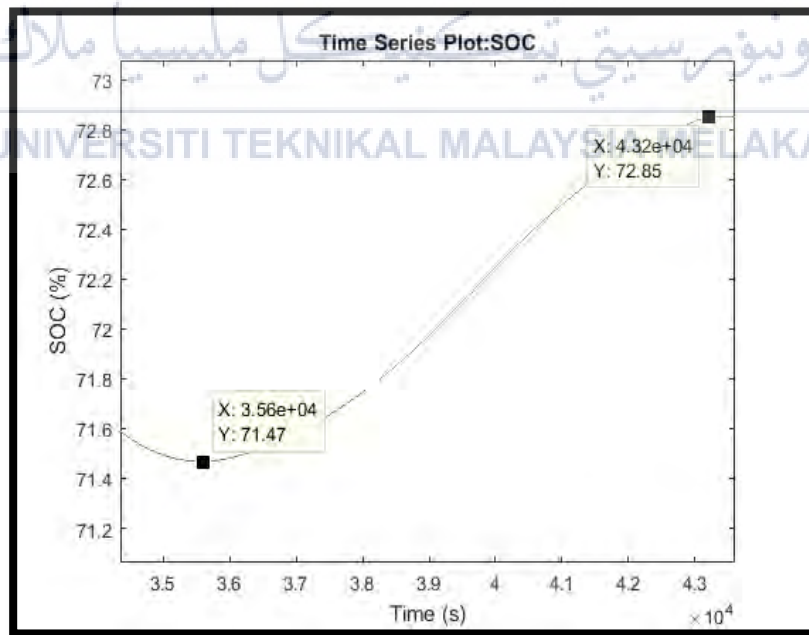

Figure 4.4 The SOC plot when in charging state.

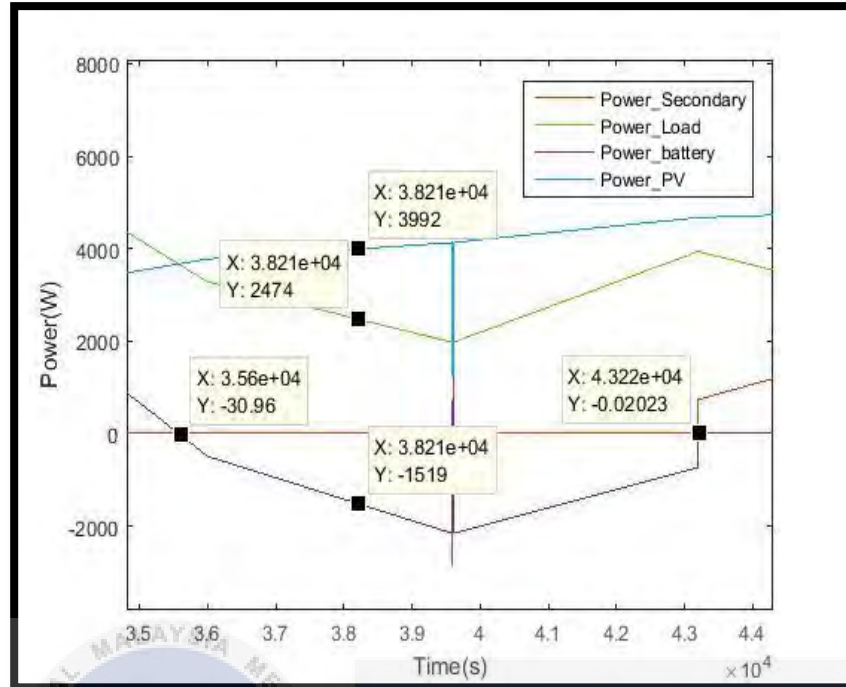

Figure 4.5 The comparison of powers when battery in charging state.

The charging process begins at 35600s (9.54am) when surpluses power from the PV system delivered to battery storage. At 38210s (10.37am), the maximum power generate by PV system was 3992W but the total of power loads demand was 2474W. A 1519W of surpluses power was delivered to the battery which is leads to battery storage in charging state.

UNIVERSITI TEKNIKAL MALAYSIA MELAKA

4.3.4 Situation 4

This situation operates in mode v. From 12.00pm until 6.00pm, the control for the battery was not active as shown in Figure 4.6. The SOC of the battery storage was not changed at 72.85% because there's no charge or discharge of the battery storage where the power from PV only was supply to the loads and surplus power was transfer to main grid.

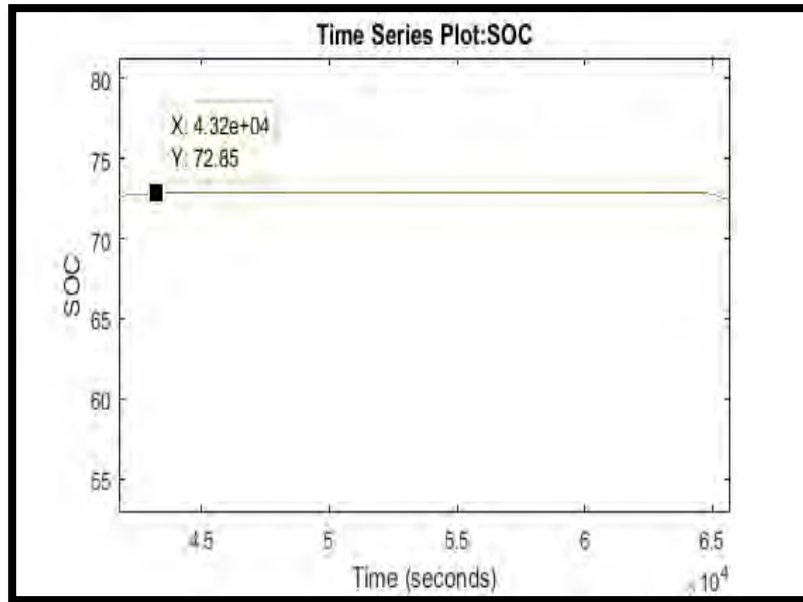

Figure 4.6 The percentage of SOC

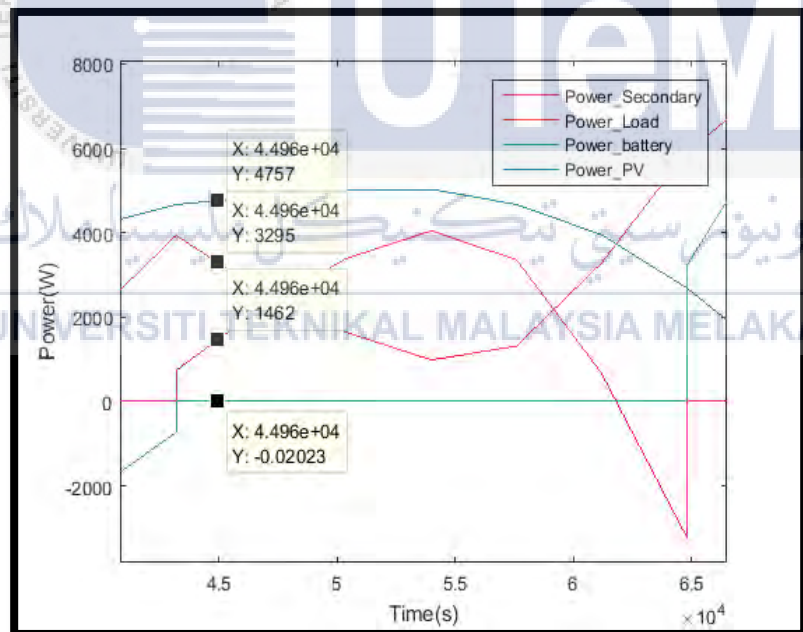

Figure 4.7 The comparison between power (W) of load, PV, battery storage and secondary side of transformer when SOC in off state.

At 44960s (12.30 pm), the total load power was 3295W and the maximum power for PV system is 4757W which is there got surplus power from PV system, then 1462W surplus

power was supply to main grid as shown in Figure 4.7 that resulting the changing of secondary side of transformer power graph line.

4.3.5 Situation 5

In this situation, the point in Figure 4.8 shown at 63600s (5.40pm) where the total loads power was 5029W. The maximum power supply from PV system was 3113W. The battery controller was not performed, so the secondary side of the transformer (main grids) has to supply the insufficient power which is 1916W to the loads. This condition more focuses in mode 1.

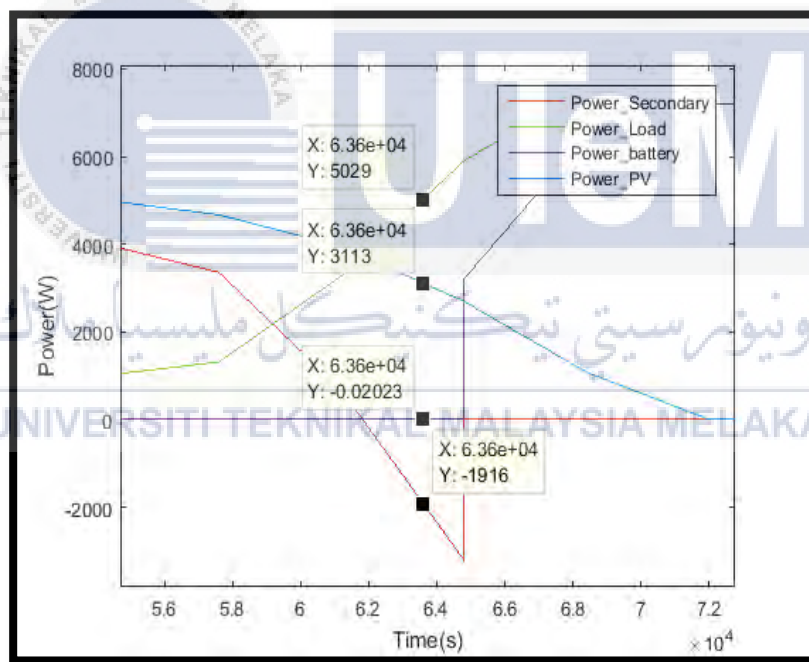

Figure 4.8 The comparison power between total loads, main grids, PV system and battery storage.

4.3.6 Situation 6

At 28800s (8.00am), the circuit breaker was set to ON for 30 second at load 1. From the Figure 4.9, the total power loads suddenly decrease from 5903W to 4921W. The PV maximum power at that time was 2157W and the supported power for load from battery suddenly changes from 3748W to 2764W because of the total loads power was change. The graph for power from secondary side of the transformer did not change because the battery controller was performed (islanded mode).

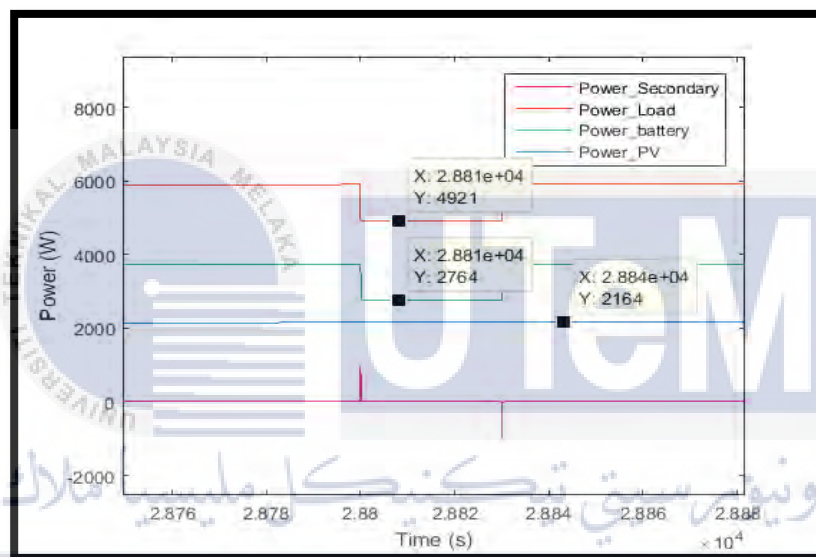

Figure 4.9 The comparison power (W) between load, PV system, battery storage and secondary side of the transformer.

4.4 Cost Estimation

The use of renewable resources can help reduce costs because there is no payment for using RES as the main source of power systems. If the power system to make full use RES as primary source, this can indirectly make the cost of electricity consumption is zero. The example of calculation of electricity cost as in analysis of situation 5 where the total power needs by loads was 5029W and the maximum power supply by the PV system was 3113W and

the 1916W of insufficient power was supplied from main grid. The cost of the electricity was calculated from this situation as per hour and based on the calculation of electricity in Malaysia.

Table 4.1 The cost of power usage

	Power Usage (kWh)	Cost (MYR)
From PV system	3.113	0.00
From Main grid	1.96	0.43
Total Loads	5.029	1.10

From the Table 4.1, it shows that without support from the PV system, the total cost for power usage was MYR 1.10 compare with support from PV system which is only MYR 0.43. Thus, PV system helps in reduce the cost of electrical energy uses.

4.5 Summary

This chapter consists of result and discussion of the analysis of power management in control strategies of micro-grid with utilizes the PV system and battery energy storage as main sources in grid connected or islanded mode. The data are recorded in graphical result of the simulation. This chapter consists of three subtopic which is simulation result, analysis the simulation result and cost calculation. The result was discussed and analyze in this chapter to meet the objective of the project.

CHAPTER 5

CONCLUSION AND RECOMMENDATION

5.1 CONCLUSION

This project proposes a control strategy for distributed integration of PV and battery energy storage in micro-grid where the battery controller will track control of the current in primary side of the transformer thus set the micro-grid system in grid connected or islanded mode. The understanding of benefit in using renewable energy source as main power supply with support from battery energy storage to supply the power to the loads and power managements is realized in the different modes on micro-grid which are grid connected or islanded states. When the power generation from PV system was not enough to accommodate electric loads, the BESS or from secondary side of transformer will supply the insufficient power. The RES also helps in reduce the cost of power usage from main grid. The concept for charging and discharging for battery was reliable which the charging process is begins when surpluses power from the PV system delivered to battery storage.

5.2 RECOMMENDATION

The solar energy is one of renewable energy that safe more money and environment. Energy storage when combined with PV system can provide a stronger economic performance, as well as an added benefit of backup power for critical loads. Micro-grid with PV and battery energy storage can provide energy storage at zero upfront for cost and improvement in technology.

REFERENCES

- [1] Ahmed T. Elsayed, Ahmed A. Mohamed, Osama A. Mohammed, DC microgrids and distribution systems, *Electric Power Systems Research*, Volume 119, February 2015, Pages 407-417.
- [2] Boqiang Lin, Jianglong Li, Analyzing cost of grid-connection of renewable energy development in China, *Renewable and Sustainable Energy*, Volume 50, October 2015, Pages 1373-1382.
- [3] A. A. Salam, A. Mohamed, M. A. Hannan, Technical Challenges On Microgrids, *ARPN Journal of Engineering and Applied Sciences*, VOL. 3, NO. 6, DECEMBER 2008, ISSN 1819-6608.
- [4] Qing Qin; Zhixin Chen; Xiaohui Wang, Overview of micro-grid energy management system research status, *Power Engineering and Automation Conference (PEAM)*, 2012 IEEE, Pages: 1 - 4, DOI: 10.1109/PEAM.2012.6612478.
- [5] F. D. Kanellos, A. I. Tsouchnikas, N. D. Hatziargyriou, Micro-Grid Simulation during Grid-Connected and Islanded Modes of Operation, *International Conference on Power Systems Transients (IPST'05)*, June 19-23, 2005 Paper No. IPST05 – 113
- [6] Abraham Ellis, David Schoenwald, PV Output Smoothing with Energy Storage, Sandia National Laboratories, March 2012, SAND2012-1772.
- [7] Heung-seok Lee, Bon-gil Koo, Sang-wook Lee, Wook Kim, June-ho Park, Optimal Control of BESS in Microgrid for Islanded Operation Using Fuzzy Logic, *Fifth International Conference on Intelligent Systems, Modelling and Simulation*, 2014, DOI 10.1109/ISMS.2014.86.

- [8] Scott Backhaus, Gregory W. Swift, Spyridon Chatzivasileiadis, William Tschudi, Steven Glover, Michael Starke, Jianhui Wang, Meng Yue, Donald Hammerstrom, DC Microgrids Scoping Study in Estimate of Technical and Economic Benefits, Los Alamos National Laboratory, March 2015, LA-UR-15-22097.
- [9] Yagmur Kircicek, Ahmet Aktas, Mehmet Ucar, Sule Ozdemir, Engin Ozdemir, Modeling and Analysis of a Battery Energy Storage System Supplied from Photovoltaic Power Source, 7th International Ege Energy Symposium & Exhibition, June 18-20, 2014.
- [10] N. Eghtedarpour, E. Farjah, Control strategy for distributed integration of photovoltaic and energy storage systems in DC micro-grids, Renewable Energy, Volume 45, September 2012, Pages 96–110.
- [11] Ye L, Hai Bo Sun, Xu Ri Song, Li Cheng Li. Dynamic modeling of a hybrid wind/solar/hydro microgrid in EMT/ATP. To be appeared in J Renewable Energy.
- [12] Yazdani A, Rita Di Fazio A, Ghoddami H, Russo M, Kazerani M, Jatskevich J, et al. Modeling guidelines and a benchmark for power system simulation studies of three-phase single-stage photovoltaic systems. IEEE Trans Power Delivery 2011;26(2):1247e64.
- [13] M. A. G. de Brito, L. P. Sampaio, G. Luigi, G. A. e Melo, and C. A. Canesin, “Comparative analysis of MPPT techniques for PV applications,” in Proc. Int. Conf. Clean Elect. Power (ICCEP), Jun. 2011, pp. 99–104.
- [14] Salameh ZM, Casacca MA, Lynch WA. A mathematical model for leadeacid batteries. IEEE Trans Energy Convers 1992;7(1):93e8.
- [15] Durr M, Cruden A, Gair S, McDonald JR. Dynamic model of a lead acid battery for use in a domestic fuel cell system. J Power Sources 2006;161(2): 1400e11.

- [16] Aganah, K.A, Leedy, A.W, A constant voltage maximum power point tracking method for solar powered systems, System Theory (SSST), 2011 IEEE 43rd Southeastern Symposium on, March 14-16, 2011, Page 125 – 130, DOI 10.1109/SSST.2011.5753790.
- [17] Amjad Anvari Moghaddam, Akiereza Seifi, Taher Niknam, Mohamad Reza Alizadeh Pahlavani, Multi-objective operation management of a renewable MG (micro-grid) with back-up micro-turbine/fuel cell/battery hybrid power source, Energy, Volume 36, Issue 11, November 2011, Pages 6490–6507.
- [18] Roberto Faranda, Sonia Leva, Energy comparison of MPPT techniques for PV Systems, WSEAS Transactions On Power Systems, Issue 6, Volume 3, June 2008.
- [19] Burri Ankaiah, Jalakanuru Nageswararao, MPPT Algorithm for Solar Photovoltaic Cell by Incremental Conductance Method, International Journal of Innovations in Engineering and Technology (IJIET), Volume 2, February 2013, ISSN: 2319 – 1058.
- [20] Yang MiHan Zhang ; Yue Tian ; Yang Yang ; Jun Li ; Jianxin Li ; Limin Wang, Control and operation of hybrid solar/wind isolated DC micro grid, Transportation Electrification Asia-Pacific (ITEC Asia-Pacific), 2014 IEEE Conference and Expo, Aug. 31 - Sept. 3, 2014, Pages 1 – 5, DOI: 10.1109/ITEC-AP.2014.6941130.
- [21] O. Tremblay, L.-A. Dessaint, A.-I. Dekkiche, "A Generic Battery Model for the Dynamic Simulation of Hybrid Electric Vehicles", 2007 IEEE® Vehicle Power and Propulsion Conference, September 9-13, 2007, Arlington/Texas, USA.
- [22] S.Saravanan, S. Thangavel, Instantaneous reference current scheme based power management system for a solar/wind/fuel cell fed hybrid power supply, Energy Systems, Volume 55, February 2014, Pages 155–170.

APPENDIX A

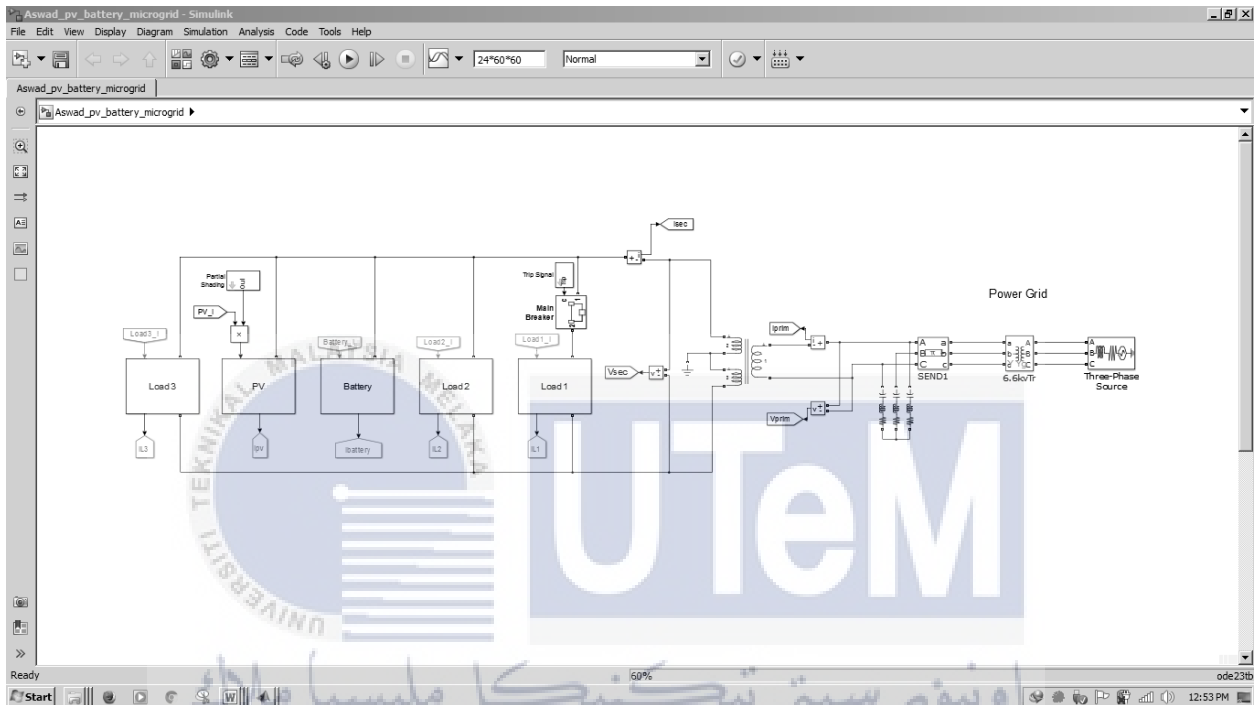

Figure A The simulation of micro-grid

APPENDIX B1

Lookup Table Editor: Aswad_pv_battery_microgrid/Scenario/Solar Data 1-D Lookup Table

File Edit Plot Help

Viewing "n-D Lookup Table" block data [T(:)]:

Breakpoints	Column	(1)
(401)	24000	1250
(402)	24060	1258.9285714285713
(403)	24120	1267.8571428571427
(404)	24180	1276.7857142857142
(405)	24240	1285.7142857142858
(406)	24300	1294.642857142857
(407)	24360	1303.5714285714282
(408)	24420	1312.5
(409)	24480	1321.4285714285716
(410)	24540	1330.3571428571427
(411)	24600	1339.2857142857142
(412)	24660	1348.2142857142856

Data Type: Row: double Column: double Table: double

Dimension Selector:

Dimension size	1441
Showing	All

Transpose display

Figure B1 Solar Data 1-D Lookup Table

APPENDIX B2

Lookup Table Editor: Aswad_pv_battery_microgrid/Scenario/Load Data 1-D Lookup Table

File Edit Plot Help

Models: Aswad_pv_battery...

Table blocks: Main Breaker, Model, Timer, Look-Up Table, Scenario, Load Data 1-D Lookup Table, Solar Data 1-D Lookup Table

Viewing "n-D Lookup Table" block data [T(:)]:

Breakpoints	Column	(1)
(585)	35040	1376.8115942028985
(586)	35100	1358.695652173913
(587)	35160	1340.5797101449275
(588)	35220	1322.463768115942
(589)	35280	1304.3478260869567
(590)	35340	1286.231884057971
(591)	35400	1268.1159420289855
(592)	35460	1250
(593)	35520	1231.8840579710145
(594)	35580	1213.768115942029
(595)	35640	1195.6521739130435
(596)	35700	1177.536231884058

Data Type: Row: double Column: double Table: double

Dimension Selector: Dimension size 1441 Showing All

Transpose display

Figure B2 Load Data 1-D Lookup Table

APPENDIX C

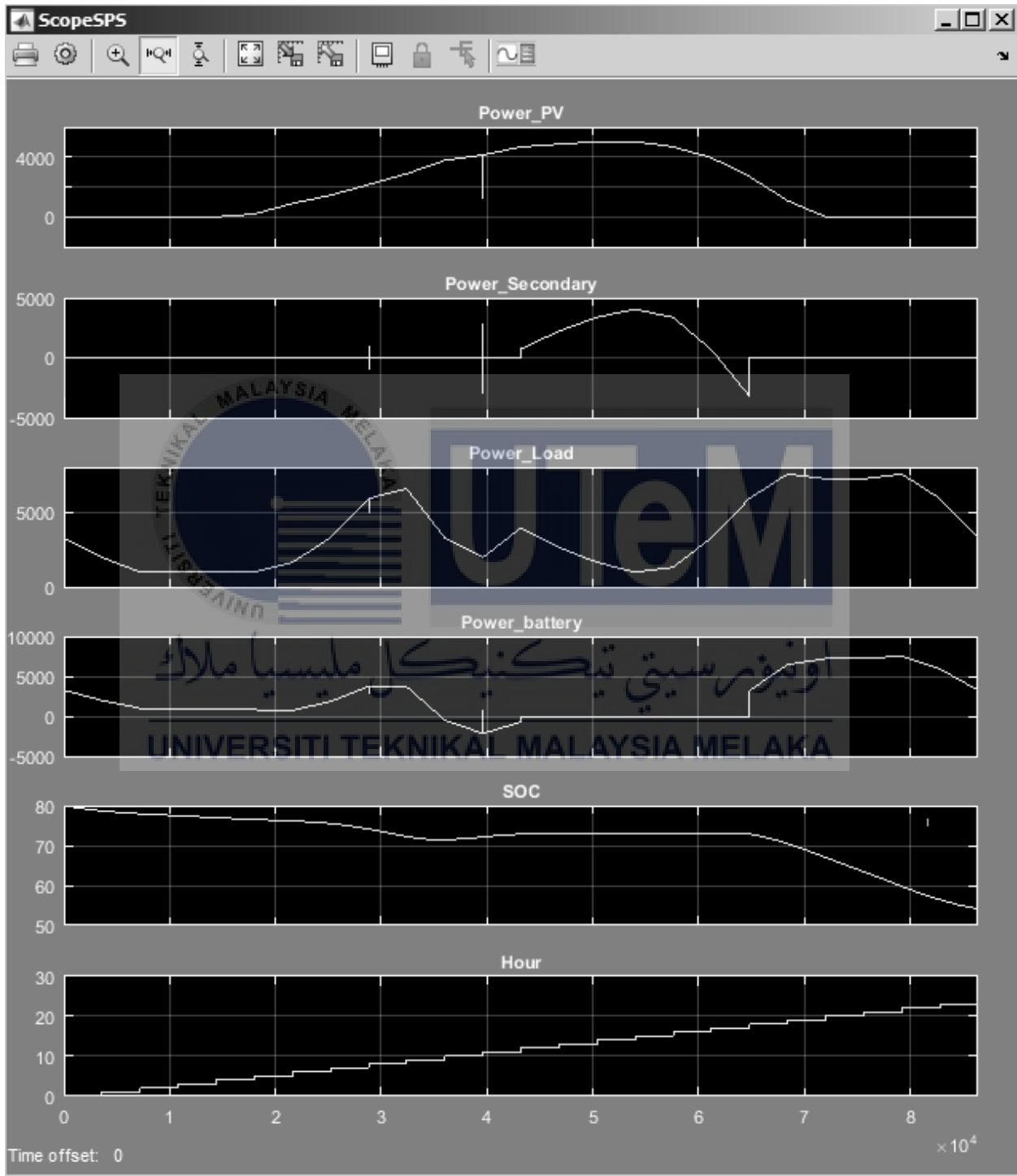

Figure C The data of simulation micro-grid system.

APPENDIX D

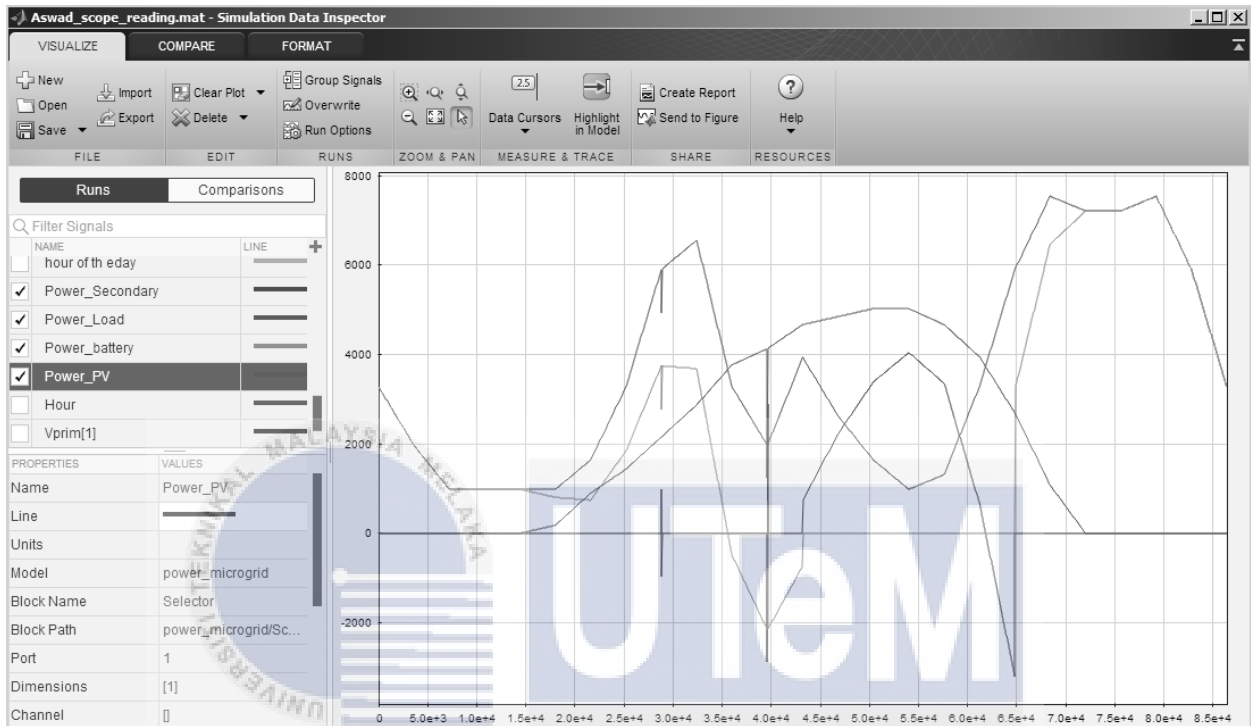

Figure D The comparison of data using simulation data inspector.