

## SUPERVISOR'S DECLARATION

"I hereby declare that I have read through this report entitle "*Modeling and Verification of Prosthetic Hand*" and found that it has comply the partial fulfillment for awarding the degree of Bachelor of Electrical Engineering (Control, Instrumentation & Automation)."

Signature : \_\_\_\_\_  
Supervisor's Name : EN. HAFIZ BIN JALI  
Date : 13<sup>th</sup> June 2016

# **MODELING AND VERIFICATION OF PROSTHETIC HAND**

**NADIA BTE. ABD. RASHID**

**This report is submitted in partial fulfillment of the requirements for the  
Degree of Electrical Engineering**

**Faculty of Electrical Engineering  
UNIVERSITI TEKNIKAL MALAYSIA MELAKA**

**2016**

### STUDENT'S DECLARATION

"I declare that this report entitle "*Modeling and Verification of Prosthetic Hand*" is the result of my own research except as cited in the references. The report has not been accepted for any degree and is not concurrently submitted in candidature of any other degree.

Signature : \_\_\_\_\_

Author : NADIA BTE. ABD. RASHID

Date : 13<sup>rd</sup> June 2016

“Dedicated to my beloved family especially my father and mother  
Abd. Rashid Bin Ahmad and Zainab Binti Mohammed”

## ACKNOWLEDGEMENT

Firstly, I would like to give my thanks to Allah for giving me strength and ability to complete the project from beginning until the end. Without His permission, I would not finish my final year project in successful.

The special thank goes to my helpful supervisor, Encik Hafiz Bin Jali. The supervision and support that he gave truly help the progression and smoothness in order to complete my final year project. I really appreciate for all the guidance and advice that have been given for me.

My grateful thanks also go to all my friend that never tired to support and help me to assemble the parts and gave suggestion about this research. Last but not least, many thanks go to my beloved family for supporting and encourage me through out of this project. I have to appreciate the guidance given by other supervisor as well as panel especially to improve my report final year project to be a more better.

## TABLE OF CONTENT

CHAPTER	TITLE	PAGE
	SUPERVISOR'S DECLARATION	i
	STUDENTS'S DECLARATION	iii
	ACKNOWLEDGMENT	v
	ABSTRACT	
	TABLE OF CONTENT	
	LIST OF FIGURE	
	LIST OF TABLE	
<b>1</b>	<b>INTRODUCTION</b>	
	1.1 Research Background	1
	1.2 Motivation	5
	1.3 Problem Statement	5
	1.4 Project Objectives	6
	1.5 Scope of Work	6
	1.6 Expected Project Outcome	6
	1.7 Proposal Outline	7
<b>2</b>	<b>LITERATURE REVIEW</b>	
	2.1 Introduction	9
	2.2 Anatomy of Human Hand	10
	2.3 Index Finger Model	11
	2.4 DC Electric Motors	12
	2.5 DC Actuator	13
	2.6 Modelling- System Identification	13
	2.7 Prosthetic Finger Kinematics	14
	2.8 The Euler Lagrange Equation	15
	2.9 MATLAB Simulink Optimization Design	16
	2.9.1 Estimate Model Parameter	16
	2.9.2 Improving the accuracy of statistical models can involve estimating:	16

	<b>2.9.3 Creating accurate parametric dynamic models can involve estimating:</b>	
	<b>2.10 Proportional Integrals Derivative Controller (PID)</b>	16
	<b>2.11 Summary of the literature review</b>	17
		18
<b>3</b>	<b>METHODOLOGY</b>	
	<b>3.1 Introduction</b>	19
	<b>3.2 Derivation of Dynamic Model of Finger Mechanism</b>	19
	<b>3.2.1 DC motor expression in the Euler-Lagrange Equation</b>	23
	<b>3.3 Simulation Set-up</b>	28
	<b>3.3.1 Block Diagram</b>	28
	<b>3.3.2 Simulation Model of Linear and Non-Linear Prosthetic Finger System</b>	29
	<b>3.3.3 Real Data Transfer Function System Identification</b>	31
	<b>3.4 MATLAB Simulink Design Optimization (Parameter Estimation)</b>	31
	<b>3.4.1 Parameter Estimation Method</b>	32
	<b>3.5 Proportional Integral Derivative (PID)</b>	39
	<b>3.5.1 Proportional Term</b>	40
	<b>3.5.2 Integral Term</b>	40
	<b>3.5.3 Derivative term</b>	40
	<b>3.6 Nonlinear Plant System with PID Controller (Auto-tune)</b>	41
	<b>3.7 Flowchart</b>	41
	<b>3.7.1 Flowchart explanation</b>	42
	<b>3.8 Summary of methodology</b>	43
		44
<b>4</b>	<b>RESULT AND DISCUSSION</b>	
	<b>4.1 Introduction</b>	45
	<b>4.2 Lagrange Linear and Non-Linear Output Response</b>	46
	<b>4.3 Simulation of Transfer Function System Identification Model</b>	48
		49
		50

4.4	Analysis of Simulation of Linear Prosthetic Finger Movement System and System Identification	50
		52
4.5	Simulink Design Optimization (Parameter Estimation)	
4.5.1	Prosthetic Hand Real Data Output Response	53
4.5.2	Result before and after optimize using Simulink Estimation Parameter	53
		56
4.6	Non-Linear Plant System with PID	
4.6.1	Tuning of PID Controller Terms	57
4.6.2	Comparison of Nonlinear with and without PID controller	
4.7	Summary of result and discussion	
<b>5</b>	<b>CONCLUSION AND RECOMMENDATION</b>	
	<b>5.1 Conclusion</b>	58
	<b>5.2 Recommendation</b>	59
<b>6</b>	<b>REFERENCE</b>	60
<b>7</b>	<b>APPENDIX</b>	
	Gantt chart	
	Datasheet DC Motor	



## LIST OF FIGURES

CHAPTER	TITLE	PAGE
<b>1</b>	<b>INTRODUCTION</b>	
		2
	<b>Figure 1.1</b> John Hoplkins APL Arm (New Launches, 2010)	2
	<b>Figure 1.2</b> DEKA Luke Arm (DEKA Research, 2009)	3
	<b>Figure 1.3</b> Bones and joints of the hand	3
	<b>Figure 1.4</b> Finger movements	
<b>2</b>	<b>LITERATURE REVIEW</b>	
	<b>Figure 2.1</b> Skeletal structure of the human hand	10
	<b>Figure 2.2</b> Flexion and extension tendon of an index finger	11
	<b>Figure 2.3</b> Physical model of the finger	11
	<b>Figure 2.4</b> Drawing of a DC motor and gear head	12
	<b>Figure 2.5</b> General block diagram of closed loop control system	13
	<b>Figure 2.6</b> Typical system identification flowchart	14
	<b>Figure 2.7</b> (a) Prototype of prosthetic finger, (b) Schematic of prosthetic finger lying in XY plane	15
<b>3</b>	<b>METHODOLOGY</b>	
	<b>Figure 3.1</b> (a) Structure of human finger	20
	(b) Flexion of angles of one finger	20
	<b>Figure 3.2:</b> Prosthetic finger's free body diagram.	24
	<b>Figure 3.3:</b> Prosthetic finger connected with DC motor.	24
	<b>Figure 3.4:</b> DC motor schematic circuit	25
	<b>Figure 3.5:</b> Field controlled DC motor	26
	<b>Figure 3.6:</b> Block Diagram of Control Strategy Design	28
	<b>Figure 3.7:</b> Simulink Block Diagram	29
	<b>Figure 3.8:</b> Expression Block in MATLAB	30
	<b>Figure 3.9:</b> List of Parameters	30
	<b>Figure 3.10:</b> Step Input	30
	<b>Figure 3.11:</b> Real data Transfer Function	31
	<b>Figure 3.12:</b> Step 1 Parameter Estimation	32
	<b>Figure 3.13:</b> Step 2 Parameter Estimation	32
	<b>Figure 3.14:</b> Step 3 Parameter Estimation	32
	<b>Figure 3.15:</b> Step 4 Parameter Estimation	33
	<b>Figure 3.16:</b> Step 6 Parameter Estimation	33
	<b>Figure 3.17:</b> Step 7 Parameter Estimation	33
	<b>Figure 3.18:</b> Step 8.1 Parameter Estimation	34
	<b>Figure 3.19:</b> Step 8.2 Parameter Estimation	34

<b>Figure 3.20:</b> Step 9 Parameter Estimation	35
<b>Figure 3.21:</b> Step 10 Parameter Estimation	35
<b>Figure 3.22:</b> Step 11.1 Parameter Estimation	36
<b>Figure 3.23:</b> Step 11.2 Parameter Estimation	36
<b>Figure 3.24:</b> Step 11.3 and 11.4 Parameter Estimation	36
<b>Figure 3.25:</b> Step 11.5 Parameter Estimation	37
<b>Figure 3.26:</b> Step 11.6 Parameter Estimation	37
<b>Figure 3.27:</b> Step 11.7 Parameter Estimation	38
<b>Figure 3.28:</b> Step 11.8 Parameter Estimation	38
<b>Figure 3.29:</b> Step 11.9 Parameter Estimation	38
<b>Figure 3.30:</b> A block diagram of PID controller in a feedback loop	39
<b>Figure 3.31:</b> Non-Linear Plant System with PID Controller	41
<b>Figure 3.32:</b> PID Controller Function Block Parameter	41
<b>Figure 3.33:</b> Flow chart for modeling and verification of prosthetic hand	42

#### 4 RESULT AND DISCUSSION

<b>Figure 4.1:</b> Linear Output Response	46
<b>Figure 4.2:</b> Non-Linear Output Response	46
<b>Figure 4.3:</b> Linear and Non-linear System Trajectory	47
<b>Figure 4.4:</b> Open loop System Identification Transfer Function	48
<b>Figure 4.5:</b> Comparison of response both method	49
<b>Figure 4.6:</b> Time, Voltage, Position Output Response	50
<b>Figure 4.7:</b> Position Output Response of Prosthetic Hand	51
<b>Figure 4.8:</b> Trajectories of $K_t$ , $K_e$ , $R$ , and $z$ of estimated parameter	51 52
<b>Figure 4.9:</b> Result of Non-linear and real data Position Output Response	52
<b>Figure 4.10:</b> Position Output before optimization	52
<b>Figure 4.11:</b> Position Output after optimization	53
<b>Figure 4.12:</b> Non-Linear Plant System with PID Controller	53
<b>Figure 4.13:</b> Non-Linear Output Response after autotune with PID Controller	54 54
<b>Figure 4.14:</b> Autotune Function Block Parameters	55
<b>Figure 4.15:</b> PID Controller performances result	56
<b>Figure 4.16:</b> Comparison performance before and after auto-tune	56
<b>Figure 4.17:</b> Nonlinear system without PID and with PID controller	
<b>Figure 4.18:</b> Non-linear output response of with and without PID	

**LIST OF TABLE**

<b>CHAPTER</b>	<b>TITLE</b>	<b>PAGE</b>
<b>3</b>	<b>METHODOLOGY</b>	
	<b>Table 3.1</b> Dynamic parameter of 1 DOF	20
	<b>Table 3.2:</b> Parameter of the linear equation	24
<b>4</b>	<b>RESULT AND DISCUSSION</b>	
	<b>Table 4.1:</b> Comparison between before and after optimization	52
	<b>Table 4.2:</b> Comparison of the performance before and after tuned	55

## ABSTRACT

This project focused on the design and modeling of prosthetic finger. At present, work on prosthetic hands finds special importance because this branch of engineering enables the mankind to think for the realizable substitute of human limb using artificial means. With the advent of realization of various type of micro-motors, this subject of prosthetic hands finds practical realization, because human limbs basically are operated with neuro motors energy being driven by the appropriate neuro signal initiated by the Automatic Nervous System (ANS) of the brain. Present paper with the simulation design of the prosthetic finger using MATLAB/Simulink software to design the performance of the response. The motion of the prosthetic finger is described considering the energies of the finger, when it is driven by input voltage of DC motor. The associated Lagrangian function of the motion of the finger is evaluated for the present study.

## ABSTRAK

Projek ini memberi tumpuan kepada reka bentuk dan model jari palsu. Pada masa ini , kerja-kerja tangan palsu mendapati kepentingan istimewa kerana cabang kejuruteraan membolehkan manusia untuk berfikir untuk pengganti yang boleh dihasilkan dari anggota badan manusia menggunakan cara-cara buatan . Dengan kedatangan merealisasikan pelbagai jenis mikro-motor , subjek ini tangan palsu mendapati kesedaran praktikal, kerana anggota badan manusia pada dasarnya beroperasi dengan motor neuro tenaga dipandu oleh isyarat neuro yang sesuai dimulakan oleh Sistem Saraf automatik ( ANS ) daripada otak. Kertas hadir dengan reka bentuk simulasi jari palsu menggunakan perisian MATLAB / Simulink untuk mereka bentuk prestasi sambutan. Pergerakan jari palsu adalah diterangkan mempertimbangkan tenaga jari, apabila ia didorong oleh input voltan DC motor. Fungsi Lagrangian bersekutu gerakan jari dinilai bagi kajian ini.

## CHAPTER 1

### INTRODUCTION

#### 1.1 Research Background

The prosthesis as a tool makes no pretence of trying to replace the lost limb's physiological appearance. As a matter of fact, it works as an aid to help provide some of the functions that were lost due to the accident, war or congenital condition. Moreover, the prosthesis is an interchangeable device that can be used only when needed. Much effort in the field of upper-extremity prosthesis research is directed towards the development of prostheses as true limb replacements. Prostheses were developed for function, cosmetic appearance, and a psycho-spiritual sense of being entire, but not necessarily in that order. These needs have existed from the past until today. Early prosthetic principles that were developed exist to this day and are amazingly efficient in function [1].

The hand is one of the important limbs of the human body. Adaptation, exploration, pretension, perception and manipulation all the gripping tasks are done by human hand [2]. The fingers on the palm of the hand more specially render the said tasks being appropriately commanded by concerned systems or subsystems. The specific gripping job is again done by the use of mechanical force available from the neuro-motors as excited by the neuro-signals transmitted by the brain. The prosthetic means the mimicking of any parts of the human bodies, like a finger. The prosthetic fingers are created with the theory for motor movement. According

to physiology, there are there parts of a human finger, which can be moved in different orientation by the human's thought.

Figures 1.1 and 1.2 show functional prototypes of the APL and Luke arms ready for testing. The arms can perform almost any task a human can. The only downside to the arms is their cost. The APL arm was a \$100 million dollar project, and the DEKA arm was a \$20 million dollar project. (Dillow, 2011) Products have not been produced, laboratory prototypes have been produced. These arms were not designed with mass production and market pricing in mind.

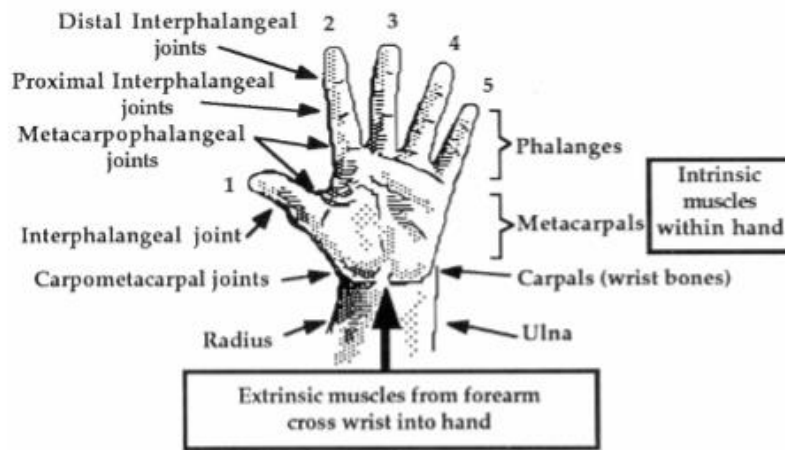

**Figure 1.1** John Hopkins APL Arm (New Launches, 2010)

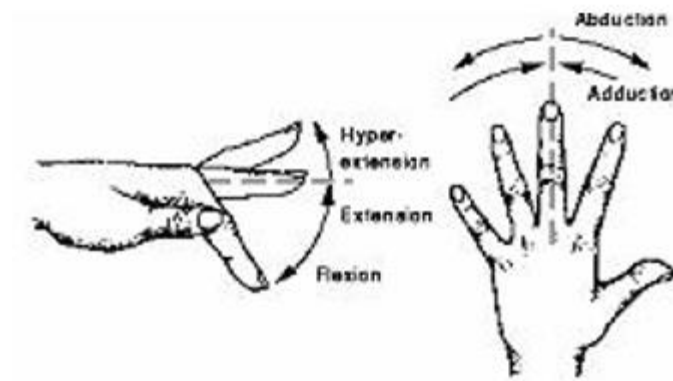

**Figure 1.2** DEKA Luke Arm (DEKA Research, 2009)

The human hand consists of five digits, four fingers and a thumb. The fingers constitute of three intercalated bony segments: the proximal, intermediate and distal phalanges. The thumb, on the other hand, lacks the intermediate phalanx and is made up of only the proximal and distal phalanges. The proximal phalange is the first phalange and is connected to the metacarpal bones, which are the bones that form the palm of the hand. The distal phalange is located at the finger end. The joints of the finger are the metacarpophalangeal (MCP) joint, the proximal interphalangeal (PIP) joint and the distal interphalangeal (DIP) joint. The bones and joints of the hand are illustrated in Figure 1.3.



**Figure 1.3** Bones and joints of the hand [3]



**Figure 1.4** Finger movements [3]



Figure 1.4 illustrates the possible movements of the MCP joint, which is a 2 DOF universal joint that provides abduction/adduction and extension/flexion motions. The PIP and DIP joints are 1 DOF revolute joints, providing extension/flexion. The DIP joint is, however, a passive DOF that follows the movements of the PIP joint through tendons connecting the two joints.

The prosthetic fingers are created with the theory for motor movement. Likening the movement of these three parts of finger considering one dimension, with the compound pendulum, consists three parts. Lagrangian motion equation of compound pendulum is worked as human finger movement with considering the linearity.

Besides these some important designed prosthetic fingers have been testified to some extent to highlight the simulating aspect. The movement of the fingers incorporated in prosthetic hand so far published is nonlinear and defused resulting in erratic gripping of the object where as the model devised by the author's is linear in nature resulting in smooth gripping of the object.

To imitate the functionality and motion characteristics of the real human hand, biomimetic studies of the human hand has become important. In several studies, biomechanical models of the human hand fingers have been developed for determining the kinematical and dynamical behaviour of hands and fingers. As a part of the project, this paper presents a methodology for dynamic modeling and trajectory tracking of a prosthetic hand.

Modelling is usually treated as a pre-processing stage for the application of a control strategy. Generally speaking, the dexterous hands have been derived based on four approaches: Newton-Euler method, Lagrange's equation, forward recursive formulation, and Kane's approach.

Usually, mathematical models are composed of thousands of equations. These models are difficult to create and even more difficult to maintain. Therefore, graphical modelling is generally more suitable for the creation of models of complex systems than equation-based modeling.

The equation based modeling can be verified by using certain simulation software. MATLAB Simulink Blocks Diagram and Simulink Design Optimization were the software that being used as simulation process.

Thus, this report will explain about designing, modeling, analyzing of a prosthetic hand. Moreover, using Proportional Integral Derivatives (PID), the desired output response could be achieved.

## **1.2 Motivation**

The design of fully functioning artificial arms and hand replacements with physiological speeds-of response and strength (or better) that can be controlled almost without thought is the goal of upper extremity prosthetics research. Unfortunately, current prosthetic components and interface techniques are still a long way from realizing this goal. The current state-of-the-art prosthesis can be considered to be a tool rather than a limb replacement. The major factors limiting prostheses to tools are practical ones due to the severe weight, power and size constraints of hand/arm systems as well as the difficulty in finding a sufficient number of appropriate control sources to control the requisite number of degrees of freedom. Of these, it is the lack of independent control sources that imposes the most severe impediment to the development of today's prosthetic hand/arm systems. As a result, upper-limb prosthetics research is somewhat dominated by considerations of control. Still, the importance of better actuators and better multifunctional mechanisms must not be ignored. Control is useless if effective hand and arm mechanisms are not available,

## **1.3 Problem Statement**

In fact, most patients or amputees feel uncomfortable when using the current commercial prosthetic hands, because they are usually heavy and unable to provide enough grasping functionality and lack of degree of freedom [4, 5].

The most commonly used myoelectric hand has one degree of freedom, opening and closing. It uses only two myoelectrodes sensors in order to increase training efficiency and practical reliability of the device. If there is need to increase the functionality of prosthetic devices, more myoelectrode sensors can be added, however at the expense of training efficiency

Prosthetic hands have been designed and developed for about last fifteen years to meet the requirements of the amputated persons [6], [7]. Unfortunately, no prosthetic design has reached the functional features of the human hand, which has magnificent mechanical properties [8].

In last years, many works have been done concerning the tendon driven mechanisms, which consist of belt pulley connections, a rotor assembly, and serial manipulator. Jacobsen used a derivative and integral controller in order to control a double actuated single joint, which is driven by tendons [9]

#### **1.4 Project Objectives**

- i. To develop the mathematical modeling of the prosthetic finger using Euler-Lagrange equation.
- ii. To evaluate the system identification modeling based on Simulink Design Optimization Parameter Estimation technique
- iii. To analyse and compare the performance of both model

#### **1.5 Scope of Work**

The prosthetic finger system used in only 1 DOF. The degree of freedom (DOF) of a mechanical system is the number of independent parameters that define its configuration. This work will emphasize on the position control of a single finger. Each joint of the finger is connected by linkage. The mathematical derivation of the model only conducted using Lagrangian equation. The derived model will be compared with system identification model based on existing prosthetic finger in the lab. The performance of the model is verified using MATLAB/Simulink via simulation. To ensure the best output performance, only using auto-tune on PID controller because this system were in time domain and only to define the stability.

## 1.6 Expected Project Outcome

As the expected project outcomes, the performance between Parameter Estimation and Real Data System Identification were simulated for the prosthetic hand in MATLAB and the end result was also computed by acquiring data from the prosthetic finger's joints. The system result and simulation result shows the similar pattern. The best and stable output response performance can be determine by using specific controller.

## 1.7 Proposal Outline

**Chapter 1** discussed the proposal of the project, what is details of the project such as the introduction of the research, an overview of the research project in whole, the problem statement, objectives, scopes and motivation of this report are defined. The report works that will be done are based on the objectives and scope that have been stated.

**Chapter 2** discussed are more of the literature reviews that related to the report such as anatomy of the human finger, dc motor actuators, and the mathematical method that will be used to derive the mathematical equation. Moreover, in this chapter, it also discusses step by step to implement and design into MATLAB/Simulink Software.

**Chapter 3** discussed the prosthetic finger model and mathematical expression used in this project. It also discussed the formula that has been using to design the relation in between voltage and position such as Lagrange Equation. Next, by using parameter estimation or known as MATLAB Simulink Optimization Design any parameter value in the system could be known using this method. Step by step using this method were described in this chapter. Proportional Integral Derivative (PID) used as the controller in this system. Simple explanations by using this controller will be describes in this chapter.

**Chapter 4** consists the result of the simulation after derive the mathematical equations. In this chapter, the equation can be proven by comparing the similar pattern response of real parameter transfer function with the response of the derivation equation that implement in MATLAB

Simulink. Then, the unknown parameter has been solved by using parameter estimation where the real response and the datasheet are required to complete the simulation system. After that, PID were connected to the system to get the desired output response.

**Chapter 5** contain the conclusion regarding on the whole work recommendation for the further works.

## CHAPTER 2

### LITERATURE REVIEW

#### 2.1 Introduction

The loss of limb can severely affect the quality of life of an amputee and thus render the most common everyday tasks difficult if not impossible. Over the last few decades, major progress has been made in the development of intelligent prostheses, which can at least partially fulfil the requirements of the missing limb. The hand is viewed as one of the most important parts of the human body as it allows for adaptation, exploration, prehension, perception and manipulation.

The concept of using the remaining muscles of a limb to operate a terminal device remained central to all development in upper limb prosthetics until the practical introduction of myoelectrically controlled prosthetics in the beginning of 1958 [1]. The myoelectric prosthesis is controlled by the action potential of the muscle that develops as a secondary to the excitation of the central nervous system. The articulated hand of the myoelectric prosthesis is usually activated through at least two sets of electrodes over an opposing muscle group, such as extensors and flexors. The electrical potential of the muscle is detected on the skin by the electrodes incorporated into the socket of the prosthesis. This potential, picked up by the electrodes, then controls the opening and closing action of the prosthesis, powered by a battery usually incorporated within the prosthesis [10].

Prior to presenting the design, analysis, and experimental aspects of the work of myoelectrical prosthetic hand, it is useful to have an historical perspective or a literature review.

## 2.2 Anatomy of Human Hand

Biomechanically, human hand has a very articulated structure and multi-segmented body. Since it has multi degrees of freedom (DOF), it is the highest functional organ of the human body. Human hand has 23 DOF that is provided by 17 joints [11]. If three dimensional movement is taken into consideration, DOF increases to 29 because of orientation and position variation of the hand. In Figure 2.1, the joints of a hand are seen.

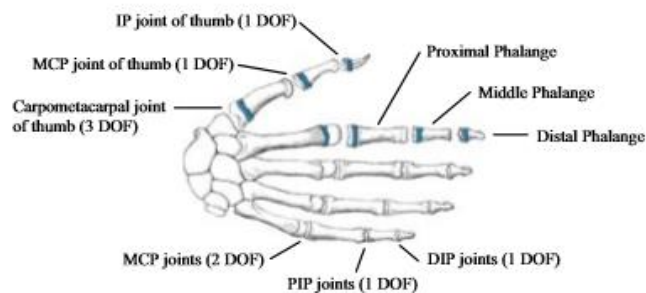

**Figure 2.1** Skeletal structure of the human hand [12]

Muscles show only pulling effect and muscle forces are transmitted to finger bones via tendons. Tendon is a connective tissue that attaches the skeletal muscles to other structures. Tendons are extensions of the muscles in the forearm and the hand. More than fifteen tendons extend from the forearm muscles to hand. While the extension–flexion movement of the hand fingers starts, a set of tendons carries out the extension motion of the finger, and another set of muscles makes the flexion motion (Figure 2.2).

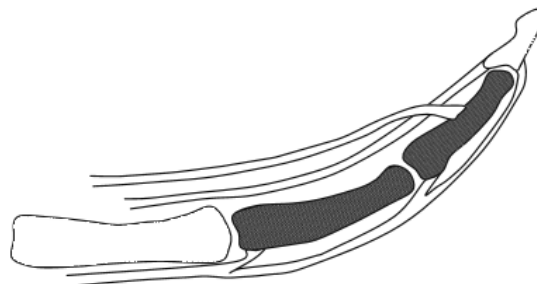

**Figure 2.2** Flexion and extension tendon of an index finger [12]

## 2.3 Index Finger Model

Three degrees of freedom prosthetic finger model is used in this study. The proximal, middle and distal phalanges of the index finger of a human hand are modelled similarly to the real index finger in length and mass. Figure 2.3 gives the physical model of the finger.

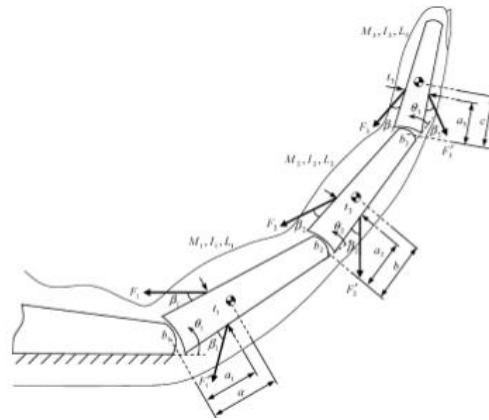

**Figure 2.3** Physical model of the finger [12]

$F_1, F_2,$  and  $F_3$  are the flexion forces and  $F_0_1, F_0_2$  and  $F_0_3$  are the extension forces.  $\beta_i$  ( $i= 1,2,3$ ) is the angle between tendon forces and phalanges. In human hand, the skin tissue covers the finger bones and tendons thus,  $\beta_i$  attains small values and in this study it is  $10^\circ$  each.  $M_i, I_i$  and  $L_i$  are the mass, mass moment of inertia and length of the related links.  $a, b$  and  $c$  are the distances of the mass centre of the first, second and third link, respectively.  $\theta_i$  is the joint angle of the related link and  $b_i$  denotes the viscous friction at the joints.  $a_i$  is the distance of the tendon attachment point to the related joint and  $t_i$  is the diameter of the related link at this point

## 2.4 DC Electric Motors

By far the most common actuator for electrically powered prostheses is the permanent magnet dc electric motor with some form of transmission (Figure 2.4)[13][14][15][16]. While there is much research into other electrically powered actuator technologies, such as shape memory alloys and electroactive polymers, none is to the point where it can compete against the dc electric motor. A review of the available and developing actuator technologies with their associated advantages and disadvantages as well as their power and force densities can be found