



**UNIVERSITI TEKNIKAL MALAYSIA MELAKA**

**DEVELOPMENT OF HIGH TECH ELECTRICITY  
SYSTEM IN AGRICULTURE FIELD**

This report submitted in accordance with requirement of the Universiti Teknikal Malaysia Melaka (UTeM) for the Bachelor Degree of Engineering Technology (Industrial Electronics) (Hons.)

by

**NOOR AKMAL B. ABD MAJID**

**B071310077**

**900322-05-5121**

FACULTY OF ENGINEERING TECHNOLOGY 2016

**BORANG PENGESAHAN STATUS LAPORAN PROJEK SARJANA MUDA**

**TAJUK: DEVELOPMENT OF HIGH TECH ELECTRICITY SYTEM IN AGRICULTURE FIELD**

**SESI PENGAJIAN: 2015/16 Semester 2**

Saya **NOOR AKMAL B. ABD MAJID**

mengaku membenarkan Laporan PSM ini disimpan di Perpustakaan Universiti Teknikal Malaysia Melaka (UTeM) dengan syarat-syarat kegunaan seperti berikut:

1. Laporan PSM adalah hak milik Universiti Teknikal Malaysia Melaka dan penulis.
2. Perpustakaan Universiti Teknikal Malaysia Melaka dibenarkan membuat salinan untuk tujuan pengajian sahaja dengan izin penulis.
3. Perpustakaan dibenarkan membuat salinan laporan PSM ini sebagai bahan pertukaran antara institusi pengajian tinggi.
4. **\*\*Sila tandakan ( ✓ )**

SULIT

(Mengandungi maklumat yang berdarjah keselamatan atau kepentingan Malaysia sebagaimana yang termaktub dalam AKTA RAHSIA RASMI 1972)

TERHAD

(Mengandungi maklumat TERHAD yang telah ditentukan oleh organisasi/badan di mana penyelidikan dijalankan)

TIDAK TERHAD

Disahkan oleh:

\_\_\_\_\_

\_\_\_\_\_

Alamat Tetap:

Cop Rasmi:

KAMPUNG GAMIN  
71550 SRI MENANTI  
NEGERI SEMBILAN,  
MALAYSIA

Tarikh: \_\_\_\_\_

Tarikh: \_\_\_\_\_

## **DECLARATION**

I hereby, declared this report entitled “Development of High Tech Electricity System in Agriculture System” is the results of my own research except as cited in references.

**Signature** :

**Name** : NOOR AKMAL B. ABD MAJID

**Date** : 09<sup>TH</sup>DECEMBER2016

## **APPROVAL**

This report is submitted to the Faculty of Engineering Technology of UTeM as a partial fulfillment of the requirements for the degree of Bachelor of Engineering Technology (Industrial Electronics) (Hons.). The member of the supervisory is as follow:

.....  
(Mr Hasrul Nisham Bin Rosly)

## **ABSTRACT**

Economic development nowadays more complex with technological advances that make life simpler. On this day, most people rely on various types of information technology in the conduct of a project as well as research and among these examples as channel through the voice activated car and many others. This ongoing project focuses on the concept of greenhouse plant cultivation with unlimited basic resources such as water and sunlight. The aim of this system is designed to build a highly capable system where the resources provided by nature will be able to maintain the plant. The exterior of this project contain of main control box which serves to control the water pump and lamp, also have some sort of sensor to measure the temperature of the soil and the greenhouse. Sensors are used to measure the temperature of the soil in turn will send a signal to the main control panel where connect to the arduino and the next will turn on either the light or the pump and turn off the process when it is appropriate. Overall, the project is carried out to generate the construction of greenhouses, run the experiment and state how the system works in a greenhouse.

## **ABSTRAK**

Kemajuan ekonomi pada masa kini seiring dengan kemajuan teknologi yang menjadikan kehidupan semakin ringkas. Pada hari ini kebanyakan masyarakat bergantung kepada pelbagai jenis teknologi dalam mencari maklumat bagi melakukan sesuatu projek serta penyelidikan dan diantara contoh tersebut seperti kereta yang diaktifkan melaluli suara serta lain-lain lagi. Projek yang dijalankan ini memberi tumpuan kepada penanaman tumbuhan berkonsepkan rumah hijau dengan sumber asas yang tidak terbatas seperti air dan juga cahaya matahari. Sistem yang direka ini bertujuan membina satu sistem berkeupayaan tinggi dimana sumber yang dibekalkan akan dapat mengekalkan sifat semulajadi tumbuhan tersebut. Bahagian luar projek ini terdapatnya kotak kawalan utama dimana berfungsi mengawal pam air serta lampub dan juga mempunyai beberapa jenis sensor bagi mengukur tahap suhu tanah serta rumah hijau tersebut. Sensor yang digunakan bagi mengukur suhu tanah seterusnya akan menghantar isyarat kepada panel kawalan utama dimana terletaknya arduino dan seterusnya akan menghidupkan sama ada lampu atau pun motor pam serta mematikan proses tersebut apabila suhu yang sesuai Secara keseluruhannya, projek yang dijalankan bagi menghasilkan kerja membina rumah hijau, menjalankan ujikaji serta menyatakan bagaimana sistem didalam rumah hijau tersebut berfungsi.

## **DEDICATIONS**

To my beloved parents, family members and friend.

## **ACKNOWLEDGMENTS**

In The Name Of Allah, the Most Beneficent and the Most Merciful. A deep sense of thankfulness to Allah SWT who has given me the full strength, ability and patience to complete this Bachelor Degree Project as it is today.

Firstly, I would like to take this opportunity to put into words my deepest gratitude and appreciation to my the project supervisor, Mr Hasrul Nisham Bin Rosly for his support, guidance, patience, encouragement and abundance of ideas during the completion of this project. Secondly, special thanks to both honourable panels, for their comments, invaluable suggestions and outstanding deliberations to improve the project during the project presentation.

I would also like to express my extraordinary appreciation to my family especially to my parents, Puan Norzalida Binti Alias and also to my family members for their invaluable support along the duration of my studies until the completion of this Bachelor Degree Project. Finally yet importantly, thanks to my beloved friends who are directly or indirectly contributed due to their supports and guidance and helped greatly to point me in the right direction until the completion of this Bachelor Degree Project.



## TABLE OF CONTENT

Abstrak	i
Abstract	ii
Dedication	iii
Acknowledgement	iv
Table of Content	v
List of Figures	vi
List of Table	vii

### CHAPTER 1

1.0 Introduction	1
1.1 Problem Statement	2
1.2 Objective	2
1.3 Scope	3
1.4 Project Outline	4

### CHAPTER 2

2.0 Introduction	5
2.1 Smart Agriculture and Controlling System	5
2.2 Research from Previous Project	6
2.2.1 Design and Implementation of the Greenhouse Monitoring System Based on GSM and RF Technologies	7
2.2.2 Automated Control System for Arduino and Android	8

Based Intelligent Greenhouse.

2.2.3 Design of Intelligent Greenhouse Environment Monitoring System	9
Based on ZigBee and embedded technology.	
2.2.4 Intelligent Agriculture Greenhouse Environment Monitoring System	9
Based on IOT	
2.3 Hardware and Software Review	10
2.3.1 Arduino Controller	11
2.3.1.1 Introduction to Arduino	11
2.3.1.2 Arduino UNO	11
2.3.1.3 Advantages of Arduino UNO	12
2.3.2 Water Pump	13
2.3.2.1 1000 L/H Submersible Water Aquarium Pump	13
2.3.3 Relay 5v dc - 240v ac	14
2.3.4 Sensor	15
2.3.4.1 Humidity Sensor	15
2.3.4.2 Moisture Sensor	15
2.3.4.3 Temperature Sensor	16
2.4 Conclusion	17
 <b>CHAPTER 3</b>	
3.0 Introduction	18
3.1 Project planning and Development	18 - 19
3.2 Flow Chart	20
3.3 Identification Part	21
3.4 Design Stage	21

3.5	Testing	22
3.6	Analysis	23
3.7	Summary	23
<b>CHAPTER 4</b>		
4.0	Introduction	24
4.1	Result	24 - 28
4.2	Discussion	28 – 44
<b>CHAPTER 5</b>		
5.0	Introduction	45
5.1	Conclusion for Chapter 1	45- 46
5.2	Conclusion for Chapter 2	46
5.3	Conclusion for Chapter 3	46 - 47
5.4	Conclusion for Chapter 4	47
5.5	Conclusion for Chapter 5	47 – 48
5.6	Commercialization Potential	48
<b>REFERENCE</b>		49 – 50
<b>APPENDICES</b>		51
APPENDIX A		

## LIST OF FIGURES

Figure 1.1: The Flowchart of the System	3
Figure 2.1: The monitoring node hardware circuit diagram	7
Figure 2.2: The sink node hardware circuit diagram	7
Figure 2.3: The structure of the control system	8
Figure 2.4: The overall system block diagram	9
Figure 2.5: The structure of the system	10
Figure 2.6: The Architecture of Arduino Uno	12
Figure 2.7: 1000 L/H Submersible Water Aquarium Pump	14
Figure 2.8: Relay 5v dc - 240v ac	14
Figure 2.9: Humidity Sensor	15
Figure 2.10: Connection of Moisture with Arduino	16
Figure 3.1: Process flow of the project	19
Figure 3.2: Stage of completing the project	20
Figure 3.3: Block connection diagram of the project	22
Figure 4.1: The front view of the greenhouse model	25
Figure 4.2: The top view of the greenhouse model	25
Figure 4.3: The high condition of the greenhouse model	26

Figure 4.4: The low condition of the greenhouse model	26
Figure 4.5: The wet range soil of the greenhouse model	27
Figure 4.6: The normal range soil of the greenhouse model	27
Figure 4.7: The dry range soil of the greenhouse model	28
Figure 4.8 Graph reading of moisture sensor for 8/9/2016	29
Figure 4.9 Graph reading of moisture sensor for 9/9/2016	30
Figure 4.10 Graph reading of moisture sensor for 10/9/2016	31
Figure 4.11 Graph reading of moisture sensor for 11/9/2016	31
Figure 4.12 Graph reading of moisture sensor for 12/9/2016	32
Figure 4.13 Graph reading of moisture sensor for 13/9/2016	33
Figure 4.14 Graph reading of moisture sensor for 14/9/2016	33
Figure 4.15 Graph reading of moisture sensor for 8/9/2016	35
Figure 4.16 Graph reading of moisture sensor for 9/9/2016	36
Figure 4.17 Graph reading of moisture sensor for 10/9/2016	37
Figure 4.18 Graph reading of moisture sensor for 11/9/2016	37
Figure 4.19 Graph reading of moisture sensor for 12/9/2016	38
Figure 4.20 Graph reading of moisture sensor for 13/9/2016	39
Figure 4.21 Graph reading of moisture sensor for 14/9/2016	39
Figure 4.22 Graph reading of average moisture versus time	42
Figure 4.23 Graph reading of average moisture value with temperature and humidity.	43

## LIST OF TABLE

Table 4.1: Reading of the moisture for chills value versus time ( % MC).	29
Table 4.2: Reading of the moisture for okra value versus time (% MC).	35
Table 4.3: Reading of the average value for okra (% MC).	41
Table 4.4: Reading of the average value for chills (% MC).	41
Table 4.5: Reading of the average moisture value versus time (% MC).	42
Table 4.6: Reading of moisture value for chills and okra with temperature and humidity (% MC).	43

# CHAPTER 1

## INTRODUCTION

### 1.0 Introduction

The agriculture field is one of the important need in the economic aspect, it become necessities because the agriculture activity all around the world demanding a produce such as plant. This type of economic nowadays becomes more efficient and modern with the like of greenhouse system. The greenhouse produce become more productive by all due to its produce and quality of the product. In addition of that in Malaysia there have many placed using this concept to growing plant at any place in different ways of plant, there also have several weaknesses and cause problem to the user such as fungus or insect and need to be improved. In this project that has been doing is about the new technology of greenhouse system. The new system that will created based on the wireless sensor that have been used to monitor all the progress of plant growth like the moisture of the soil, humidity and also temperature of the greenhouse. The purpose of this project is to solve the problem that been faced especially the farmers. This project is to share the new idea about the high tech greenhouse system in order to get the quality produce. Furthermore it can give the farmers continuously produce for the plant to growth without thinking especially the condition of temperature and soil. This project will use a few sensors as prototype. In order to use this system farmers can control any device electronic for example lamp, water sprinkle and sensor by using the control panel outside the house. Finally by using this sensors farmers get to know on the condition of the soil whether the condition

suitable so that the plant can growth according to the desired level that of the plant itself. The desired level has been show on the control panel outside of the box outside.

## **1.1 Problem Statement**

There are a lot of problem regarding the growing environment in the green house system. Therefore, the main idea to produce this project is based on the problem that were faced by the farmers and government that related in agriculture field, because environment changes in seasons bring about changes in the external and internal temperature of the greenhouse. These changes compel the grower to view things inside and outside the greenhouse differently. Although the idea is to attempts to keep the temperature inside the greenhouse uniforms. A change of the temperature because outside temperature increase out of comfort range or air move through greenhouse for cooling that bring unbalance temperature in different area will give different temperature due to the condition of the soil. The other problem view, farmers with fungus spores and small insects which is effect the growth of the plant and this give the plant with any outside or dangerous poison or disease.

## **1.2 Objective**

Those objectives evaluated to assist and completing this project:

- a. To design advance technology system that given continues source.
- b. To builds new green technology system source using an Arduino.
- c. To create a model based on new green technology system and concept.



### 1.3 Scope

The scope for this project to build HIGH-TECH systems in order to give continuous source to the plant so it will growth with the same condition according to its nature. At the outside of the box will be a control panel with the water pump that been used to pump the water for the water sprinkler and for controlling the light. In this project also there has been used of sensor to measure the level of temperature inside the greenhouse, humidity and also moisture of the soil. The sensor used in order to detect the level of moisture of the soil and after that will transmit the signal to the control panel for light to be turn on and off according to desired level of soil condition. Humidity also been use to detect if there any water in the air that can effected the growth the plant. All of these sensors has been control by Arduino that been connect to the circuit and give many advantage when using it such as open source, not so expensive for the cost, lower power consumption and lastly has many reference in order to create the coding for program. The Figure 1.1 shows diagram which represents the activity diagram of system. It shows the process of flow of activities.

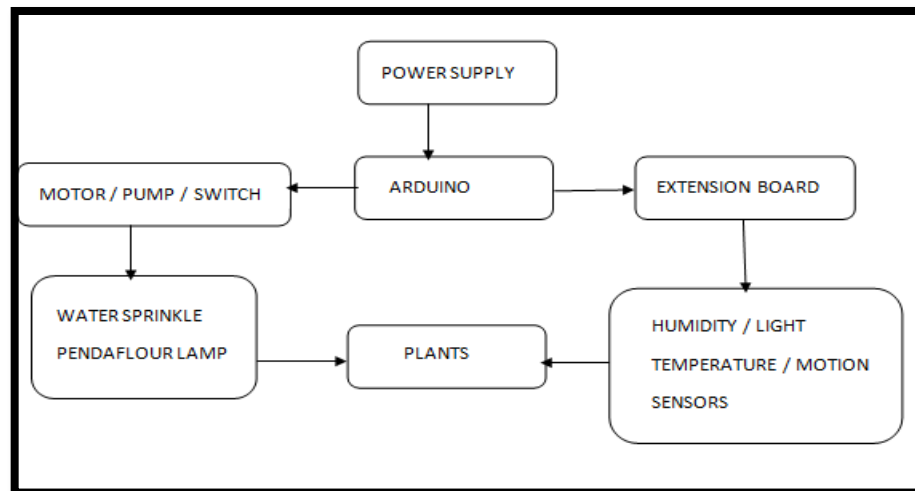

Figure 1.1: The Flowchart of the System

## 1.4 Project Outline

- a. Chapter 1 about describes the project, a problem statement, objective and also the scope of this project.
- b. Chapter 2 been explained briefly about the literature review regarding and relate to this project
- c. Chapter 3 process of construct and define the methodology that to be conduct that relate with practical and theory.
- d. Chapter 4 about the result and analysis regarding the experiment that been doing.
- e. Chapter 5 constructs the discussion of the result and analysis that been collected on the experiment process.
- f. Chapter 6 about to conclude the objective of this project whether achieve or not and recommendation for future improvements.

## **CHAPTER 2**

### **LITERATURE REVIEW**

#### **2.0 Introduction**

In this chapter, the literature review contains the information and also the idea for completing this project being discussed. There are many resource had been taken for this project such as books, journal, and also website. Beside, information about circuit, hardware and software which use in the project also include. This chapter also makes the study about the previous project in order to make some adjustment to improve or take some idea for this project. This kind of thing being very important and useful to complete the project that created.

#### **2.1 Smart Agriculture and Controlling System**

Greenhouse technology has been in many style of farming that improves from one type to another type. The use of electricity is the main source of energy that been use now days and become one of the factors that related to energy source and it connected in many things such as agriculture. In this project the main focus to the plant growth by using this source by implement the green house concept. There are prototype based on the wireless and microcontroller device has been created. In order using this it can automatically control by setting the desire level according to surrounding. Hence the saving of electricity can be more efficient and effective by using the greenhouse concept.

As the technology evolved over the last decade the world is becoming increasingly to face the problem of high-quality food shortage. One way to solve partially this problem is to use intelligent information technology for growing plants using intelligent greenhouse technology (Teslyuk, Denysyuk, Kernytskyy, & Teslyuk, 2015). In order to prevent these losses, various ways have been developing such as greenhouse system and also hydroponic ways. Therefore the use of wireless sensor and Arduino would be controlling the electrical used and minimum the maintenance. Thus this project to introduce the development system facilitates for farmers to optimize the usage electricity by using this smart system.

The plant that growth will be given the source like water and sun continuously according to it needed. Cultivation technique of greenhouse is the way to growth of plant that does not depend on the surrounding and keep the best of preserve environment by artificially controlling the environment(Kang et al., 2008). Thus the prototype to gives the owner or farmer minimize losses because of temperature balance and also living thing.

## **2.2 Research from Previous Project**

Research from other previous project was needed in order to complete this project. It was very helpful to improve the system that has been revealed before this. In the other reason some of the technologies that been used in the previous project and other help from other studies in order to get use about the function and to master the technology that have been used in order to complete the project.

## 2.2.1 Design and Implementation of the Greenhouse Monitoring System Based on GSM and RF Technologies

In this previous project there has been another way in order to monitoring the system in greenhouse by using GSM and RF technologies which is radio frequencies that been closed communication. This communication also by using integrated the radio frequency. Radio frequency technology regional environment information monitoring network and combine with GSM remote communication. These system also consists of three part of hardware which is Hardware Design of Monitoring Nodes, Hardware Design of Sink Node and lastly remote communication that been referred to GSM network. The architecture of both systems has been shown in figure 2.1 and figure 2.2.

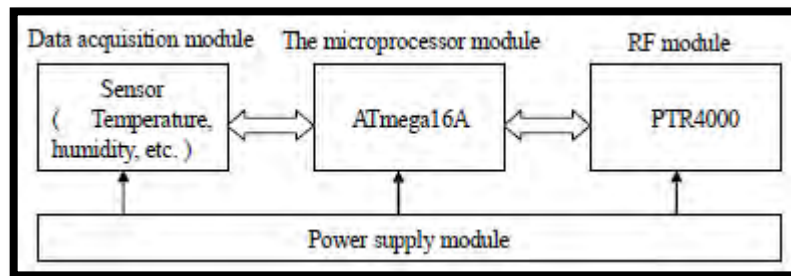

Figure 2.1: The monitoring node hardware circuit diagram.

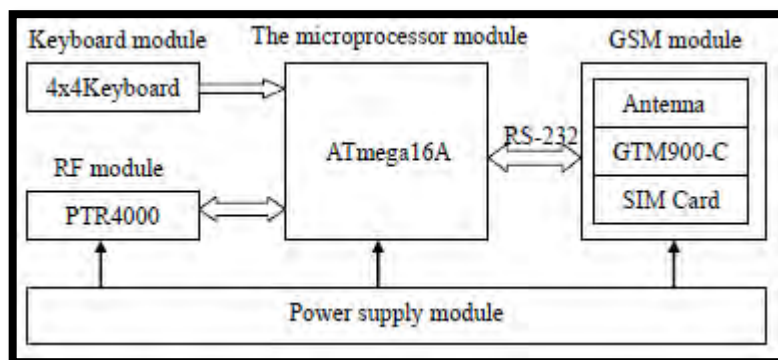

Figure 2.2: The sink node hardware circuit diagram.

### 2.2.2 Automated Control System for Arduino and Android Based Intelligent Greenhouse.

In this project there used of Arduino and Android for controlling the system based on intelligent greenhouse. This system created to control of the intellectual greenhouse, collect statistics on system performance, system time setting. The data that has been collected from sensor, actuator and current activities that been doing during that time. It also communicates in two ways between the android and Arduino microcontroller that transmit the signal after receiving from the actuator and sensor used. The structure of control system has been shown in figure below.

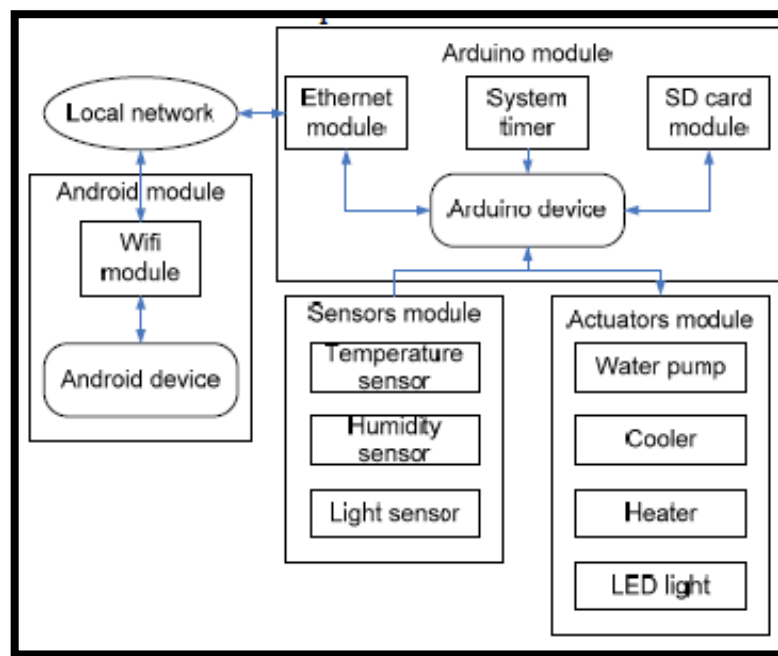

Figure 2.3: The structure of the control system

### 2.2.3 Design of Intelligent Greenhouse Environment Monitoring System Based on ZigBee and embedded technology.

In this project based on to design the greenhouse environment monitoring system also but using ZigBee and embedded technology. These system been created in order to meet requirement and sustained of crop growth in greenhouse precision agriculture. Wireless ZigBee network also used of multiple sensor such as humidity and temperature. It also set the warning in order to meet the actual condition. Figure below show the overall system block diagram at figure 2.4.

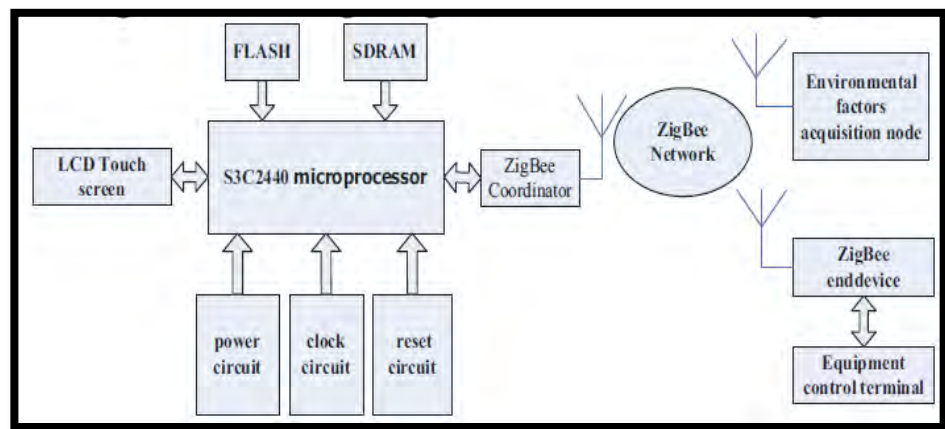

Figure 2.4: The overall system block diagram

### 2.2.4 Intelligent Agriculture Greenhouse Environment Monitoring System Based on IOT

This project of greenhouse monitoring system used another method which is IOT (Internet of Thing). The objective of these systems to control the climatic condition for crop and there are several advantage for system such as low cost also low power consumption. Sensor also used in this project to collect the information like temperature, humidity and

pressure inside the greenhouse. Figure 2.5 show the structure of the system.

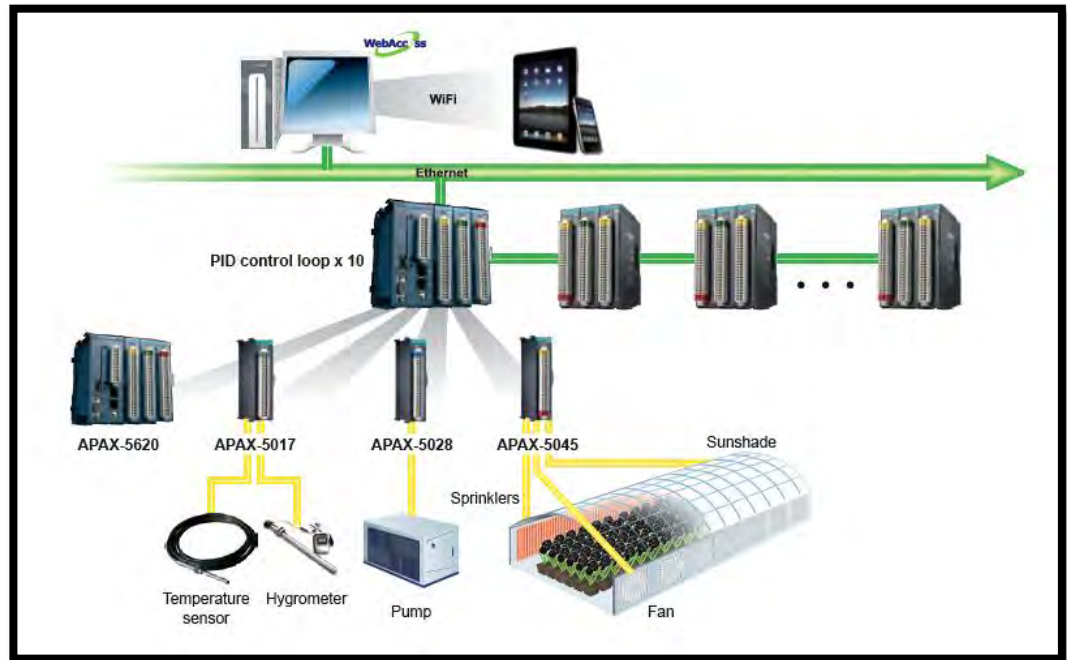

Figure 2.5: The structure of the system

### 2.3 Hardware and Software Review

These parts to review about hardware and software that will use on these project. This part is very important as it will explain some critical information about the parts and also the components for the hardware. There also with some knowledge with the regard of the software.