

# **FPGA – BASED LINE FOLLOWING ROBOT**

**NURUL IZZATY SYAFINAZ BINTI SAIFUL AZRAN**

**A report submitted in partial fulfillment of the requirements for the degree  
of Bachelor Degree in Electronic Engineering ( Computer Engineering)**

**Faculty of Electronics & Computer Engineering  
UNIVERSITI TEKNIKAL MALAYSIA MELAKA**

**JUNE 2016**



**UNIVERSITI TEKNIKAL MALAYSIA MELAKA**  
**FAKULTI KEJURUTERAAN ELEKTRONIK DAN KEJURUTERAAN KOMPUTER**

**BORANG PENGESAHAN STATUS LAPORAN**  
**PROJEK SARJANA MUDA II**

**Tajuk Projek** : .FPGA-BASED LINE FOLLOWING ROBOT

**Sesi Pengajian** :

1	5	/	1	6
---	---	---	---	---

Saya NURUL IZZATY SYAFINAZ BINTI SAIFUL AZRAN mengaku membenarkan Laporan Projek Sarjana Muda ini disimpan di Perpustakaan dengan syarat-syarat kegunaan seperti berikut:

1. Laporan adalah hakmilik Universiti Teknikal Malaysia Melaka.
2. Perpustakaan dibenarkan membuat salinan untuk tujuan pengajian sahaja.
3. Perpustakaan dibenarkan membuat salinan laporan ini sebagai bahan pertukaran antara institusi pengajian tinggi.
4. Sila tandakan (  ) :

**SULIT\***

\*(Mengandungi maklumat yang berdarjah keselamatan atau kepentingan Malaysia seperti yang termaktub di dalam AKTA RAHSIA RASMI 1972)

**TERHAD\*\***

\*\* (Mengandungi maklumat terhad yang telah ditentukan oleh organisasi/badan di mana penyelidikan dijalankan)

**TIDAK TERHAD**

Disahkan oleh:

\_\_\_\_\_  
 (TANDATANGAN PENULIS)

\_\_\_\_\_  
 (COP DAN TANDATANGAN PENYELIA)

Tarikh: .....

Tarikh: .....

“I hereby declare that the work in this project is my own except for summaries and quotations which have been duly acknowledge.”

Signature : .....

Author : Nurul Izzaty Syafinaz Binti Saiful Azran

Date : 16 June 2016

“I acknowledge that I have read this report and in my opinion this report is sufficient in term of scope and quality for the award of Bachelor of Electronic Engineering (Computer Engineering) with Honours.”

Signature : .....

Supervisor's Name : En. Sani Irwan B. Md Salim

Date : 16 June 2016

*This is dedicated to all my beloved people in my life especially my family, friends, and those who have been there for me all this while.*

## ACKNOWLEDGEMENT

I am grateful to God for the mercy and blessing given to me to fulfil my Final Year Project, FPGA-Based Line Following Robot.

In preparing this project, I would like to express my gratitude to these people who have helped me along the way. This project could not have been fulfilled without help of as my supervisor, Mr. Sani Irwan Bin Md Salim. Thank you very much for patiently guided me through the completing this final year project.

My sincere appreciation also goes to my family especially my parents who have morally and financially supported me from the beginning of my studies. Thank you for always reminding me to never procrastinate with my work and to always believe in myself.

Thanks to all my friends who have provided assistance in numerous ways; the words of wisdom, the tips and advices given definitely have helped me fulfil this final year project. Not to forget, thanks to all people who have helped me to fulfil this final year project.

Finally, I would like to thank myself for never giving up in completing this project. Thank you very much.

## ABSTRACT

The purpose of this project is to design a line following robot that uses FPGA as the controller. The project is addressing the limitations in the existing of microcontroller. The existing microcontroller do have its limitation problem and needed to be replace with new technology. If the system requires expansion or additional features, designer have no options but has to replace the board. This requires extra man hours and cost. Hence, this project is set up to demonstrate the capability of FPGA in handling future system expansion or future upgrading issues. The project includes implementation of FPGA-based controller using 8-bit data bus and utilizing four sensors and two DC motors. Spartan-6 Papilio Pro FPGA board is used as the main controller for the hardware. This project was developed with the main objective of designing line follower robot controller in Verilog HDL. Verilog is the main programming language and it will programmed into the FPGA to configure the input and output of the line follower robot. Although FPGA is the technology that were used for big project development but it can still be used for small kit to give the knowledge on FPGA. The implementation of FPGA as robot controller has provide flexibility in re-designing the controller if additional functions are required in the future.

## ABSTRAK

Tujuan projek ini adalah untuk melaksanakan pengawalan FPGA dalam robot mengikut garisan. Projek ini menangani batasan dalam mikropengawal sedia ada. Mikropengawal yang sedia ada mempunyai masalah had dan perlu digantikan dengan teknologi baru. Sekiranya sistem ini memerlukan perkembangan atau ciri-ciri tambahan, pereka tiada pilihan lain selain menggantikan papan pengawal. Ini memerlukan lebih masa dan kos yang lebih. Projek ini termasuk pelaksanaan pengawal berasaskan FPGA menggunakan 8-bit bus data dan menggunakan empat sensor dan dua DC motor. Papan teknologi FPGA yang digunakan adalah papan Spartan-6 Papilio Pro FPGA sebagai pengawal utama untuk perkakasan. Projek ini telah dibangunkan dengan objektif utama untuk mereka bentuk robot mengikut garisan pengawal dalam Verilog HDL. Verilog adalah bahasa pengaturcaraan utama dan ia akan diprogramkan ke dalam FPGA untuk mengkonfigurasi input dan output daripada robot mengikut garisan. FPGA. Walaubagaimanapun, ia adalah teknologi yang digunakan untuk pembangunan projek yang besar tetapi ia masih boleh digunakan untuk kit kecil untuk memberi pengetahuan asas tentang FGPA. Penggunaan FPGA sebagai pengawal robot memberi fleksibiliti dalam mereka semula pengawal sekiranya terdapat sebarang ciri-ciri tambahan yang diperlukan pada masa hadapan.



## TABLE OF CONTENTS

CHAPTER	TITLE	PAGE
	PROJECT TITLE	i
	REPORT STATUS VERIFICATION FORM	ii
	STUDENT'S DECLARATION	iii
	SUPERVISOR'S DECLARATION	iv
	DEDICATION	v
	ACKNOWLEDGEMENT	vi
	ABSTRACT	vii
	ABSTRAK	viii
	TABLE OF CONTENT	ix
	LIST OF TABLE	xii
	LIST OF FIGURE	xiii
	LIST OF ABBREVIATIONS	xv
<b>I</b>	<b>INTRODUCTION</b>	<b>1</b>
1.1	Project Overview	1
1.2	Objectives	2
1.3	Problem Statement	2
1.4	Scope	2
1.5	Thesis Organization	2
<b>II</b>	<b>LITERATURE REVIEW</b>	<b>4</b>
2.1	Introduction to FPGA	4
2.1.1	FPGA Architecture	5
2.2	Microcontroller	5
2.3	Differences between FPGA and microcontroller	5

<b>2.4</b>	<b>A Line Follower Robot from Design to Implementation: Technical Issues and Problem</b>	<b>6</b>
2.4.1	Introduction	6
2.4.2	Methodology	7
2.4.3	Result	10
<b>2.5</b>	<b>A Soft IP Core for a Reflective Optical Sensor in a Robot System on Chip</b>	<b>10</b>
2.5.1	Introduction	10
2.5.2	Methodology	11
2.5.3	Result	14
<b>2.6</b>	<b>Reconfiguration of Mobile Robot</b>	<b>16</b>
2.6.1	Introduction	16
2.6.2	Methodology	16
2.6.3	Result	18
<b>III</b>	<b>METHODOLOGY</b>	<b>19</b>
3.1	Introduction	19
3.2	Flowchart	19
3.3	Block Diagram	21
3.3.1	Sensors	21
3.3.2	Sensor Module	22
3.3.3	Robot Controller	23
3.3.4	Motor	23
3.3.5	Motor Module	24
3.3.6	Field Programmable Gate Array (FPGA)	24
3.3.7	Comparator	26
3.4	Software Application	28
3.4.1	Verilog	28

<b>IV</b>	<b>RESULT AND DISCUSSION</b>	<b>29</b>
<b>4.1</b>	<b>Hardware</b>	<b>29</b>
<b>4.1.1</b>	<b>Input (Sensor)</b>	<b>29</b>
<b>4.1.2</b>	<b>FPGA</b>	<b>30</b>
<b>4.1.3</b>	<b>Output (Motor)</b>	<b>33</b>
<b>4.2</b>	<b>Software</b>	<b>36</b>
<b>4.2.1</b>	<b>Simulation</b>	<b>36</b>
<b>4.3</b>	<b>Discussion</b>	<b>40</b>
<b>V</b>	<b>CONCLUSION AND RECOMMENDATION</b>	<b>41</b>
<b>5.1</b>	<b>Conclusion</b>	<b>41</b>
<b>5.2</b>	<b>Future Recommendation</b>	<b>42</b>
	<b>REFERENCES</b>	<b>43</b>

**LIST OF TABLES**

<b>NO.</b>	<b>TITLE</b>	<b>PAGE</b>
<b>4.1</b>	<b>Motor movement according to input from sensor</b>	<b>34</b>

## LIST OF FIGURES

NO. OF FIGURE	TITLE	PAGE
2.1	Line follower block diagram	7
2.2	Sensors location method	8
2.3	Schematic of IR sensor	8
2.4	Driver and motor circuit	9
2.5	Front and rear wheels	10
2.6	The TCND5000 Reflective Optical Sensors on the Gecko3 Robot	12
2.7	Sensor Infra-Red Emitter & Receiver	13
2.8	The SoC solution for the robot line-following project	14
2.9	The Experimental Procedure – Sensor Motion over a Grayscale	14
2.10	IP core outputs for sensor motion over a quantized grayscale surface (10 bit resolution setting)	15
2.11	IP core outputs for sensor motion over a quantized grayscale surface (7 bit resolution setting)	15
2.12	Block diagram	17
2.13	Simulation of white line follower and black line follower using control	17

<b>3.1</b>	<b>Flowchart of the project</b>	<b>20</b>
<b>3.2</b>	<b>Block diagram of the line following robot</b>	<b>21</b>
<b>3.3</b>	<b>How IR sensor works</b>	<b>22</b>
<b>3.4</b>	<b>IR Sensor (Transmitter and Receiver)</b>	<b>22</b>
<b>3.5</b>	<b>How a DC motor works</b>	<b>23</b>
<b>3.6</b>	<b>DC motor</b>	<b>24</b>
<b>3.7</b>	<b>Basic FPGA architecture</b>	<b>25</b>
<b>3.8</b>	<b>Spartan-6 Papilio Pro board</b>	<b>26</b>
<b>3.9</b>	<b>Block Diagram of Comparator LM339</b>	<b>27</b>
<b>3.10</b>	<b>Comparator LM339</b>	<b>27</b>
<b>4.1</b>	<b>4 pairs of IR sensors placed under the robot</b>	<b>30</b>
<b>4.2</b>	<b>I/O ports at the FPGA connected to sensor and motor</b>	<b>31</b>
<b>4.3</b>	<b>I/O ports Wing 1 A &amp; B are used</b>	<b>32</b>
<b>4.4</b>	<b>Spartan-6 Papilio Pro board embedded with the line following robot</b>	<b>33</b>
<b>4.5</b>	<b>Two DC motor used in this robot</b>	<b>35</b>
<b>4.6</b>	<b>RTL Schematic diagram</b>	<b>36</b>
<b>4.7</b>	<b>I/O ports location</b>	<b>36</b>
<b>4.8</b>	<b>Input/Output Simulation</b>	<b>37</b>
<b>4.9</b>	<b>Line Following Robot</b>	<b>38</b>
<b>4.10</b>	<b>Snapshot of working line following robot on track</b>	<b>39</b>
<b>4.11</b>	<b>Snapshot of line following robot on another track</b>	<b>39</b>

## ABBREVIATIONS

FPGA	–	Field Programmable Gate Array
I/O	–	Input/Output
IR	–	Infrared
HDL	–	Hardware Description Language
RISC	–	Reduce Instruction Set Computer
ADC	–	Analog-to-Digital Converter

## CHAPTER I

### INTRODUCTION

#### 1.1 Project overview

A line following robot usually utilize a microcontroller as the brain for it to function. There are many types of microcontroller available in the market. Each of it has its own characteristic and function. Nonetheless, there is a clear limitation when using a microcontroller as the input and output pins are preconfigured according to its packaging. This characteristic of a microcontroller will halt any changes or expansion for the design and function in future. This project is proposed with the aim of designing a line following robot controller in Verilog Hardware Description Language (Verilog HDL) and implement the hardware design in the Field Programmable Gate Array (FPGA). This project will implement FPGA-based controller using 8-bit data bus utilizing four sensors and two servo motors. The controller modules are developed in FPGA environment and tested using Spartan 6 FPGA board. At the end of this project, a working line following robot is developed successfully using FPGA as its brain and has the capability of controlling the input sensors and output motors according to the algorithm. Line following robot is a robot that is used to detect black lines drawn on white surfaces, or vice versa. Line following robot has many usage and is applicable in the industries and daily life. Verilog HDL is a programming language that is used to describe a hardware to



make it able to function according to the needs of the user. It is most commonly used in describing digital circuits at the register-transfer level (RTL).

## **1.2 Objectives**

The objective of this project is to design and develop a line follower robot controller using Field Programmable Gate Array (FPGA).

## **1.3 Problem Statement**

Usually, a line following robot use a microcontroller as the controller for the system. However, there are some limitation when using a microcontroller as the input output pins are preconfigured according to the packaging. If there is any changes in the design or in need of adding new features, the microcontroller needs to be replaced as a whole. To overcome this limitation, FPGA is used instead of microcontroller as the input and output pins are reconfigurable and will accommodate all the required pins for the system.

## **1.4 Scope**

The scope of this project is to implement the FPGA-based controller on the line following robot. Verilog HDL will be used to describe the hardware architecture. Spartan-6 FPGA board is utilized as the platform for the hardware programming. In this project, the line following robot will accommodate four infrared sensors as the input and two servo motors as the output to determine the direction of the robot.

## **1.5 Thesis Organization**

This thesis consists of five chapters: Introduction, Literature Review, Methodology, Result and Analysis, and Conclusions and Recommendations.

Chapter 1 is introduction which in this chapter, the background of this project is described in this thesis to have a clear understanding. For Chapter 2, the theories related

to FPGA and existing project related to this project will be discussed. The concept and the fundamental basis of FPGA will also be included in this chapter.

In Chapter 3, the methodology for this project is discussed. It will be focused on the hardware development and the experimental setup. The experimental results and analysis of the prototype will be discussed in Chapter 4.

This thesis ends with Chapter 5 that concludes the project and some recommendations for the future research and development.

## **CHAPTER II**

### **LITERATURE REVIEW**

This chapter summarizes the literature review on theoretical concepts applied in this project. It contains the information that the project required in order to develop and complete the entire project.

#### **2.1 Introduction to FPGA**

Field Programmable Gate Arrays (FPGA) are reconfigurable hardware devices that can be reprogrammed to implement different combinational and sequential logic created with the aim of prototyping digital circuits, as they offer flexibility and speed. They are alternative to implementation of digital logic in systems. In recent years, the advance in technology have permitted to construct FPGAs with considerable large amounts of processing power and memory storage, and as so they have been applied in several domains (telecommunications, robotics, pattern recognition tasks, infrastructure monitoring, etc.). It designed the flexibility to create a wide array of logic circuits at a low cost because it is not necessary to manufacture a new custom made integrated circuit each time. It can be programmed to implement any digital design from a very simple 'AND' circuit to a very complex multiplexer circuit. The first FPGA contains 64 CLBs and 58 inputs and outputs. Today's FPGA can contain about 330,000 logic blocks and around 1100 inputs and outputs.

### **2.1.1 FPGA Architecture**

Field Programmable Gate Arrays (FPGAs) are pre-fabricated silicon devices that can be electrically programmed in the field to become almost any kind of digital circuit or system. The general FPGA architecture consists of three types of modules. They are I/O blocks or Pads, Switch Matrix/ Interconnection Wires and Configurable logic blocks (CLB). The basic FPGA architecture has two-dimensional arrays of logic blocks with a means for a user to arrange the interconnection between the logic blocks. The functions of an FPGA architecture module are discussed below:

- Configurable Logic Block (CLB) includes digital logic, inputs and outputs. To implement the combinational and sequential logic
- Interconnects is the wires to connect the inputs and outputs to the logic blocks.
- I/O Blocks is the special logic blocks at periphery of device for external connections

### **2.2 Microcontroller**

Microcontroller is a single integrated circuit that at least contains the necessary elements of a complete computer system; CPU, memory, a clock oscillator, input and output [18]. A microcontroller can be found in almost all electronic devices. It allows a designer to create a program with input and output. Microcontrollers with 8 bits are the most commonly used since it is cheaper but enough for general purpose applications. Nowadays, the microcontrollers are widely used as the controller of mobile robot.

### **2.3 Differences between FPGA and microcontroller**

Almost every single device that is meant to connect and interact with a computer has an embedded microcontroller inside to facilitate the communication. The main and the most significant difference between the microcontroller and the FPGA is the structure of a microcontroller is comparable to a simple computer placed on a single chip with all

of the necessary components like memory and timers embedded inside. It is programmed to do some simple tasks for other hardware. A Field Programmable Gate Array or FPGA is an integrated circuit that could contain millions of logic gates that can be electrically configured to perform a certain task.

FPGA does not have a fixed hardware structure, on the opposing, it is programmable according to user applications. However, processors have a fixed hardware structure. It means that all the transistors memory, peripheral structures, and the connections are constant. The very basic nature of FPGAs allows it to be more flexible than most microcontrollers. The term field programmable already tells that the whole FPGA device can be reprogrammed to do any logic task that can be fitted into the number of gates that it has. Microcontrollers already have their own circuitry and instruction set that the programmer must follow in order to write code for that microcontroller which restricts it to certain tasks. It can be said that the very significant differences between FPGA and microcontroller is FPGA is reprogrammable by the end user however the microcontroller is preconfigured by the manufacturer and has limitation on what user can do with it.

## **2.4 A Line Follower Robot from Design to Implementation: Technical Issues and Problem**

### **2.4.1 Introduction**

A line following robot is a self-operating mobile machines that follows a line drawn on the floor. The path can be a visible black line on a white surface, or vice versa. The basic operation of the line follower are as follows:

- Capture the line position using optical sensors mounted at front end of the robot.
- Steering the robot to track the line using any steering mechanism by using a servo operation.

- Controlling the speed according to the lane condition. When passing a curve, the speed is limited due to the friction of the tire and the floor.

This robot can be used for military purposes, delivery services, transportation systems and blind assistive applications.

### 2.4.2 Methodology

This robot is divided into several parts which are sensors, Analog-to-Digital Converter (ADC) and sensor circuit, processor, driver, actuators (motors and wheels) and chassis and body structure.

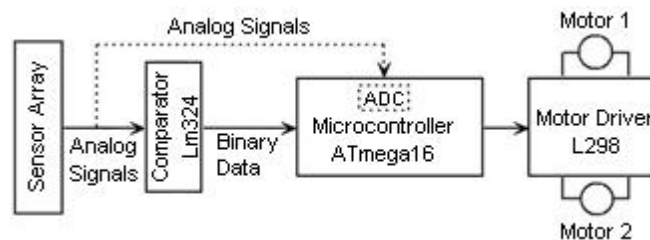

Figure 2.1: Line follower block diagram

This robot uses Infrared Ray sensors to find path and direction. Infrared Ray sensors contain a match infrared transmitter and infrared receiver pair. White surfaces generally reflect well but black surfaces reflect poorly. These devices work by measuring the amount of light that is reflected into the receiver. The distance between the sensors and ground surface is important. The distance between the sensor and each other is also important. Eight sensors are used in this project with suitable distance from each other. The competition line width was 18mm.

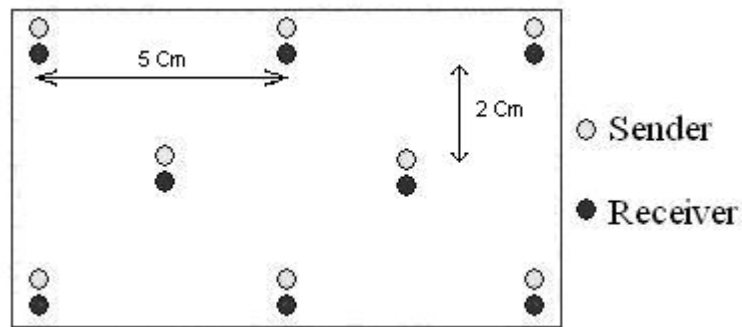

Figure 2.2: Sensors location method

The received signals from the sensors are in analog form and must be converted to the digital form. Therefore, the circuit can be designed to send the sensors' signals to the processor, directly. Hence, the processing time can be managed just by using an external ADC. LM324 is good ADC have been used in this project. Two LM324 can support eight sensors.

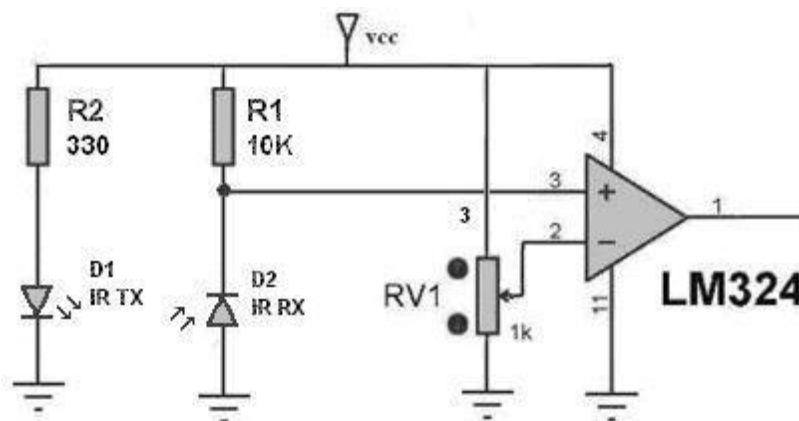

Figure 2.3: Schematic of IR sensor

The processor Atmel's AVR microcontroller "At Mega 16" is used in this project. The Atmel's AVR microcontrollers have a Reduced Instruction Set Coding (RISC) core running single cycle instructions and a well-defined I/O structure. Internal oscillators,

timers, UART, SPI, pull-up resistors, pulse width modulation, ADC, analog comparator and watch-dog timers are some of the features that will be found in AVR devices. One of the best AVR is the "At Mega 16" which has four ports for I/O and 16 MIPS speed in 16 MHz. The microcontroller power is 5V and it is better to use the 7805 regulator.

A robot needs a driver IC for controlling and giving power to the motors. The microcontroller sends a signal to the driver which acts as a switch. The microcontroller only sends a signal to the switch and then the switch must give required voltage to the motors. If the received signal by the driver is high, it will rotate the motors.

High speed motors and high sensitivity sensors circuit are used. ATmega16 and driver L298 were used to control direction and speed of motor. IC L298 is used in this project which can be used to control two motors. It is an integrated monolithic circuit in 15-lead Multiwatt and Power SO20 packages. It is a high voltage, high-current dual full-bridge driver designed to accept standard TTL logic levels and drive inductive loads such as relays, solenoids, DC, and stepping motors.

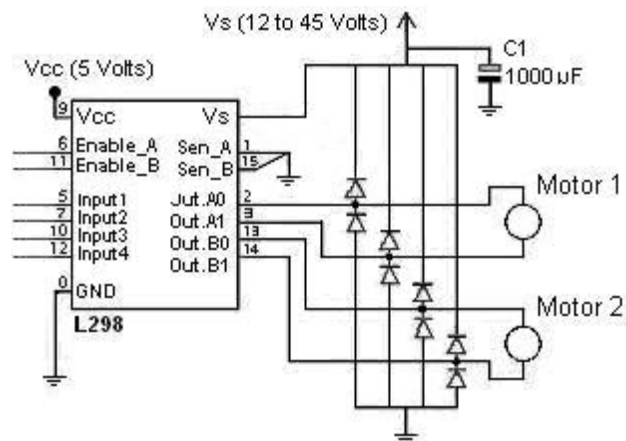

Figure 2.4: Driver and motor circuit

The movement system is an important part of a robot and its objective is how to move robot from one point to another point. Usually there are two movement systems for robots which is wheel and tank system. It is better to use wheels for line follower robots.