



UNIVERSITI TEKNIKAL MALAYSIA MELAKA

SPEED CONTROL OF DC MOTOR USING MOSFET

This report is submitted in accordance with the requirement of Universiti Teknikal Malaysia Melaka (UTeM) for the Bachelor of Electrical Engineering Technology (Industrial Power) with Honours

by

AHMAD MURSYID BIN RAMLI

B071210434

900812035211

FACULTY OF ENGINEERING TECHNOLOGY
2015

BORANG PENGESAHAN STATUS LAPORAN PROJEK SARJANA MUDA

TAJUK: **SPEED CONTROL OF DC MOTOR USING MOSFET**

SESI PENGAJIAN: **2015/16 Semester 1**

Saya **AHMAD MURSYID BIN RAMLI**

mengakumembenarkan Laporan PSM ini disimpan di Perpustakaan Universiti Teknikal Malaysia Melaka (UTeM) dengan syarat-syarat kegunaan seperti berikut:

1. Laporan PSM adalah hak milik Universiti Teknikal Malaysia Melaka dan penulis.
2. Perpustakaan Universiti Teknikal Malaysia Melaka dibenarkan membuat salinan untuk tujuan pengajian sahaja dengan izin penulis.
3. Perpustakaan dibenarkan membuat salinan laporan PSM ini sebagai bahan pertukaran antara institusi pengajian tinggi.
4. ****Silatandakan (✓)**

SULIT

(Mengandung maklumat TERHAD yang telah ditentukan oleh organisasi/badan di mana penyelidikan dijalankan)

TERHAD

(Mengandung maklumat yang berdarjah keselamatan atau kepentingan Malaysia sebagaimana yang termaktub dalam AKTA RAHSIA RASMI 1972)

TIDAK TERHAD

Disahkan oleh:



(TANDATANGAN PENULIS)

(TANDATANGAN PENYELIA)

Alamat Tetap:

RPT Chenulang,

18000 Kuala Krai,

Kelantan.

Cop Rasmi:

PROF. MABYA ABDUL LATIFF BIN MD AHOOD
Penyerah Kanan
Jabatan Teknologi Kejuruteraan Elektrik
Fakulti Teknologi Kejuruteraan
Universiti Teknikal Malaysia Melaka

** Jika Laporan PSM ini SULIT atau TERHAD, sila lampirkan surat daripada pihak berkuasa/organisasi berkenaan dengan menyatakan sekali-sebaldan tem pohlaporan PSM ini perludikelaskansebagai SULIT atau TERHAD.

DECLARATION

I hereby, declare this report entitled “**SPEED CONTROL OF DC MOTOR USING MOSFET**” is the results of my own research except as cited in references.

Signature :.....
Name : AHMAD MURSYID BIN RAMLI
Date : 11/12/2015

APPROVAL

This report is submitted in accordance with the requirement of Universiti Teknikal Malaysia Melaka (UTeM) for the Bachelor of Electrical Engineering Technology (Industrial Power) with Honours. The member of the supervisory is as follow:

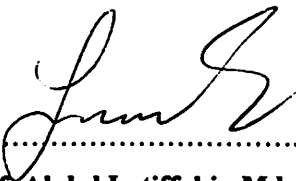

.....

(Assoc. Prof. Abdul Latiff bin Md Ahood)

ABSTRACT

The purpose of this project is to control the speed of DC motor using MOSFET (Metal Oxide Semiconductor Field Effect Transistor), to explore its use and to suggest other areas of application. DC (Direct Current) motors have been widely used in many industrial application due to its precise and continuous control characteristics. In theory, the DC motor speed is directly proportional to the supply voltage, so if the voltage is reduce from 12 to 6 volts the speed decrease by half. In practice, the supply voltage cannot be change all the time to control the motor speed so the MOSFET as the switching device will turn supply ON and OFF, where switching is done so fast that the motor only notices average voltage effect and not the switching operation. This project consists of PWM (Pulse Width Modulation) circuit to control voltage output at the motor and used MOSFET as the switching device. PWM circuit based on timer NE555 as the heart of the circuit is connected as astable multivibrator whose duty cycle can be varied from 0-100% by adjusting the 100k variable resistor. The output of NE555 is connected to the gate of MOSFET that will drives the motor at demanded speed. The higher the value of duty cycle the higher the voltage across the motor resulting in an increase in motor speed. This control circuit is very cheap and easy to implement and manage to control speed of DC motor smoothly. The application of this project is very useful in industrial nowadays depending on the type of DC motor used such DC shunt and DC series motor. For the DC shunt, it can be use in train and automotive traction application while DC series it can be use in elevators application. It is possible to improve overall performance speed control of DC motor in future work by using micro-controller or micro-processor to gives pulse to the switching device so that the speed variation remain constant. Besides that , IGBT can be use instead of MOSFET as the switching device so we can drive higher voltage application such as 220 volts DC motor at higher power requirement.

ABSTRAK

Projek sarjana muda ini berkaitan dengan kawalan kelajuan motor AT dengan menggunakan MOSFET (Metal Oxide Semiconductor Field Effect Transistor). Motor AT (Arus Terus) digunakan secara meluas dalam aplikasi industri antaranya adalah kenderaan elektrik, kren elektrik, dan kawalan robotik disebabkan ketepatan, luas, ringkas dan kawalan berterusan. Secara teori, kelajuan motor AT berkadaran langsung dengan bekalan voltan, jika nilai voltan dikurangkan dari 12volt kepada 6volt maka kelajuan juga akan berkurang separuh. Secara praktikal, bekalan voltan tidak boleh ditukar setiap masa jadi MOSFET sebagai alat suis akan menghidupkan dan memutuskan bekalan voltan secara sangat laju sehingga motor tidak dapat mengesan operasi suis yang berlaku dan hanya berjaya mengesan voltan purata. Projek ini mengandungi litar PWM (Pulse Width Modulation) untuk mengawal voltan keluar di motor dan menggunakan MOSFET sebagai alat suis. Litar PWM menggunakan NE555 sebagai komponen utama yang disambungkan secara "astable multivibrator" di mana "duty cycle" dapat dikawal dari 0-100% dengan mengawal perintang pemboleh ubah 100k. Keluaran dari litar PWM akan disambungkan pada kaki "gate" MOSFET yang akan mengawal kelajuan motor. Semakin tinggi nilai "duty cycle" semakin tinggi voltan melalui beban, makanya akan menyebabkan kelajuan motor akan bertambah dan begitulah sebaliknya. Ia adalah mungkin untuk meningkatkan kawalan kelajuan Prestasi keseluruhan DC motor dalam kerja-kerja masa depan dengan menggunakan mikro-pengawal atau mikro-pemproses untuk memberikan nadi kepada peranti pensuisan supaya perubahan kelajuan yang kekal tidak berubah. Selain itu, IGBT boleh menggunakan bukan MOSFET sebagai peranti pensuisan jadi kami boleh memandu aplikasi voltan tinggi seperti 220 volt DC motor pada keperluan kuasa yang lebih tinggi.

DEDICATIONS

Specially dedicated to my beloved family.

ACKNOWLEDGMENTS

I would like to express my gratitude towards Allah SWT for his blessing that help me to finish my bachelor degree project. I am also grateful towards my family and supervisor **Assoc. Prof. Abdul Latiff bin Md Ahood** for their invaluable guidance and moral support. Lastly, I would like to thanks any person which contributes to this project directly or indirectly for their comments and suggestions, which was crucial for the successful completion of my project.

TABLE OF CONTENTS

DECLARATION	iv
APPROVAL.....	v
ABSTRACT	vi
ABSTRAK	vii
DEDICATIONS.....	viii
ACKNOWLEDGMENTS	ix
TABLE OF CONTENTS	x
LIST OF FIGURES	xiv
LIST OF TABLE	xv
LIST OF SYMBOLS AND ABBREVIATIONS	xvi
CHAPTER 1	1
1.0 Introduction	1
1.1 Background	1
1.2 Problem Statement	2
1.3 Objective	2
1.4 Scope	2
CHAPTER 2	3
2.0 Introduction	3
2.1 DC Motor	3
2.1.1 DC Motor Speed	4

2.1.2	DC Shunt Motor	4
2.1.3	DC Compound Motor	5
2.1.4	DC Series Motor	5
2.2	Power Switches	6
2.2.1	Thyristor	6
2.2.2	MOSFET	7
2.2.3	IGBT	8
2.3	PWM Principle	9
2.4	PWM Design	10
CHAPTER 3		11
3.0	Introduction	11
3.1	Flowchart.....	12
3.2	Gantt Chart	13
3.4	Simulation Approach.....	14
3.4.1	Proteus Software	14
3.5	Hardware Implementation.....	16
3.5.1	Complete Hardware	16
3.5.2	DC Power Supply.....	17
3.5.3	DC Motor	17
3.5.4	MOSFET.....	18
3.5.5	Tachometer.....	18
3.5.6	PWM Circuit.....	19
CHAPTER 4		20

4.0	Introduction	20
4.1	Experimental Results.....	20
4.1.1	Duty cycle=10% Vout=3.70v Speed=33rpm	21
4.1.2	Duty cycle=30% Vout=7.78v Speed=73rpm	22
4.1.3	Duty cycle=50% Vout=9.50v Speed=112rpm	23
4.1.4	Duty cycle=70% Vout=10.87v Speed=149rpm	24
4.1.5	Duty cycle=90% Vout=11.31v Speed=198rpm	25
4.1.6	Data Collection.....	26
4.2	Discussion	27
4.2.1	Relationship between Duty cycle and Motor Voltage	27
4.2.2	Relationship between Duty cycle and Motor Speed	28
4.2.3	Relationship between Motor Voltage and Motor Speed	29
4.2.4	Relationship between Duty Cycle, Motor Voltage and	30
	Motor Speed.....	30
4.3	Overall Discussion	31
CHAPTER 5		33
5.0	Introduction	33
5.1	Conclusion.....	33
5.2	Suggestions for Future Work	34
5.3	Significance of project.....	34
5.3.1	Advantages of project	34
5.3.2	Application In Industries.....	35
	Table 5-1 : Application In Industries	35

5.4 Problems Faced During Research	35
APPENDIX A	38
REFERENCES.....	39

LIST OF FIGURES

Figure 2.1: DC Motor.....	3
Figure 2.2: Power Switches.....	6
Figure 2.3: Thyristor	7
Figure 2.4: MOSFET	8
Figure 2.5: PWM Waveform.....	10
Figure 2.6: PWM Design	10
Figure 3.1: Flowchart.....	12
Figure 3.2: Gantt Chart	13
Figure 3.3: PWM Schematic.....	14
Figure 3.4: PCB Layout	15
Figure 3.5: 3D View.....	15
Figure 3.6: Complete Hardware.....	16
Figure 3.7: DC power supply	17
Figure 3.8: DC Motor.....	17
Figure 3.9: MOSFET	18
Figure 3.10: Tachometer	18
Figure 3.11: PWM Circuit	19
Figure 4.1: Duty Cycle 10% Motor Voltage 3.70v	21
Figure 4.2: Duty Cycle 30% Motor Voltage 7.78v	22
Figure 4.3: Duty Cycle 50% Motor Voltage 9.50v	23
Figure 4.4: Duty Cycle 70% Motor Voltage 10.87v	24
Figure 4.5: Duty Cycle 90% Motor Voltage 11.31v	25
Figure 4.6: Graph of Duty Cycle VS Motor Voltage.....	27
Figure 4.7: Graph of Duty Cycle VS Motor Speed.....	28
Figure 4.8: Graph of Motor Voltage VS Motor Speed	29
Figure 4.9: Graph of Duty Cycle VS Motor Voltage and Motor Speed	30
Figure 4.10: MOSFET circuit	31
Figure 4.11: Voltage and Current Amplitude	32

LIST OF TABLE

Table 4-1: Data Collection.....	26
Table 4-2 : Value of Duty Cycle and Motor Voltage.....	27
Table 4-3 : Value of Duty Cycle and Motor Speed	28
Table 4-4 : Value of Motor Voltage and Motor Speed	29
Table 4-5 : Value of Duty Cycle, Motor Voltage and Motor Speed.....	30
Table 5-1 : Application In Industries	35

LIST OF SYMBOLS AND ABBREVIATIONS

AC	=	Alternating Current
DC	=	Direct Current
IGBT	=	Insulated Gate Bipolar Transistor
MOSFET	=	Metal Oxide Semiconductor Field Effect Transistor
PWM	=	Pulse Width Modulation
PCB	=	Printed Circuit Board
τ	=	Torque
>	=	More than

CHAPTER 1

INTRODUCTION

1.0 Introduction

A couple of decades before, the variable speed drives had many limitations such as larger build and lower speed. Then, the power transistors such as MOSFET, IGBT etc emerged and the introduction of micro-controllers completely changed the scene. Today, the variable speed drive is not only smaller in size but also very reliable and efficient and able to meet all the industrial demands.

DC motors are widely used in industrial applications because of its versatile characteristics such as speed can easily be control over wide range of rated speed. DC motors also gives high starting torque as high as 500% compared to normal operating torque. The methods used to control the motor are also much simpler and cheaper than AC motor.

The main purpose to control motor speed is to drive the motor at demanded speed. There are many forms of DC motor speed control, but for this project the method of PWM technique using MOSFET was chosen as this technique has better advantages over the voltage control of the DC motor.

1.1 Background

This project is done to study speed control of dc motor using power switches, MOSFET. This project consists of 12 volts dc supply, 12 volts dc motor and PWM circuit. DC supply used to supply 12 volts dc input into the PWM circuit. For this project, MOSFET was choose as switching device because of its advantage at higher switching frequencies. Then, pulse width modulation PWM circuit is used to control the motor speed by varying the duty cycle between 0-100%.

1.2 Problem Statement

DC motors play a very important role in industries nowadays, so to be able to control dc motor speed is one way to make the motor work more efficiently. In variable speed drive application, DC motor are used widely because it has many positive attributes that are needed in industries such as high starting torque and wide range of speed control. Thus, a speed controller is very important to control DC motor speed through different types of conditions at the desired speed.

1.3 Objective

- i. To study DC motor speed control methods
- ii. To study the relationship between duty cycle and the motor voltage
- iii. To conduct the experimental work to demonstrate how the speed of DC motor is controlled by PWM circuit using MOSFET as the switching device

1.4 Scope

To control the speed of 12 volts DC motor using MOSFET as the switching device and develop the hardware to drive the DC motor by controlling duty cycle of pulse width modulation (PWM) circuit .

CHAPTER 2

LITERATURE REVIEW

2.0 Introduction

This chapter will discuss on the theory and current developments in speed control of DC motor using MOSFET.

2.1 DC Motor

DC motors are divided into three types based on the way their field windings are excited. Field windings associations for the three types of DC motors have been indicated below.

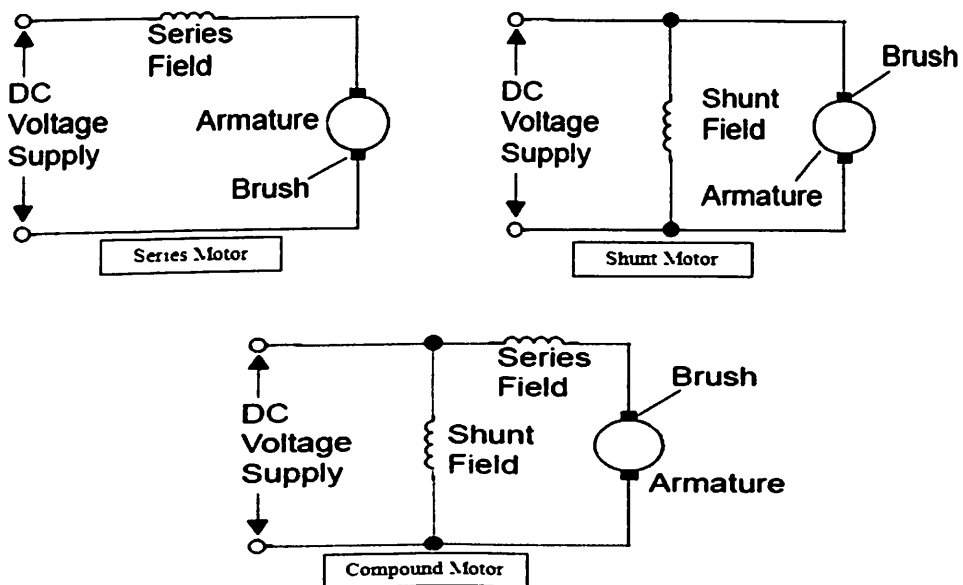

Figure 2.1: DC Motor

2.1.1 DC Motor Speed

Back emf of a DC motor E_b is the induced emf due to rotation of the armature in magnetic field. By using EMF equation of a DC motor the value of the E_b can be obtain.

$$N \propto K (E_b/\phi)$$

Where, N = speed of DC motor

Φ =flux per pole (Weber)

E_b =back emf (volts)

K = constant

Thus, speed is directly proportional to back emf and inversely proportional to the flux per pole.

2.1.2 DC Shunt Motor

DC shunt motor also known as constant speed motor because the changes of speed from no load to full load approximately between 6% to 8%. Therefore for constant speed drives in industry, dc shunt motors can be employed. But this motor cannot compete with constant speed squirrel cage induction motor because the latter is cheaper, rugged and requires less maintenance.

Synchronous motors and dc shunt motors always comes to mind when the concern is constant speed service at low speeds. However, for adjustable speed service at low operating speed, dc shunt motor is a preferred choice.

2.1.3 DC Compound Motor

A compound motor with a strong series field has its characteristics approaching that of a series motor. Therefore such type of compound motors are used for loads requiring heavy starting torque which are likely to be reduced to zero. A compound motor with weak series field has its characteristics approaching that of a shunt motor. Weak series field causes more drooping speed torque characteristics than with an ordinary shunt motors. Such compound motors with steeper characteristics, are used where load fluctuates between wide limits intermittently.

2.1.4 DC Series Motor

The outstanding feature of series motor is the automatic decrease in speed as soon as increased load torque is required. The decreasing speed with increase in load torque or vice versa has only a marginal effect on the power taken by the series motor.

Since a series motor can withstand severe starting duties and can furnish high starting torques , it is best suited for driving hoists, trains , excavators ,cranes, etc. wound motor induction motors compete favourably with series motors ,but the choice is governed by the economics . However for traction purposes , series motor is the only choice. Therefore series motors are widely used in all types of electric vehicles, electric trains, streetcars, battery powered tools, automotive starter motors etc.

Series motors can be used to drive permanently connected loads, such as fan load, because their torque requirement increases with the square of the speed. In order to avoid the pollution in big cities, now battery driven automobiles are being introduced on a large scale.

2.2 Power Switches

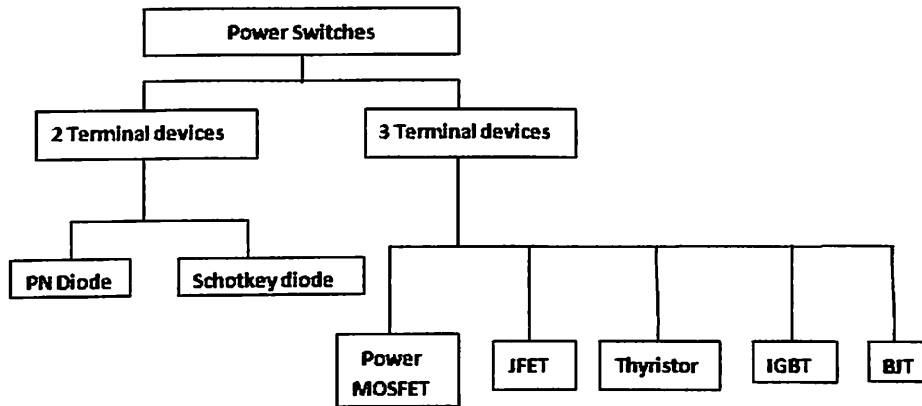

Figure 2.2: Power Switches

2.2.1 Thyristor

Thyristors or silicon-controlled rectifiers (SCRs) have been the traditional workhorses for bulk power conversion and control in industry. The modern era of solid-state power electronics started due to the introduction of this device in the late 1950s. Basically, it is a trigger into conduction device that can be turned on by positive gate current pulse but once the device is on, a negative gate pulse cannot turn it off. The device turn on process is very fast and turn off process is slow because the minority carriers are to be cleared from the inner junctions by “recovery and recombination” processes.

Commercial thyristors can be classified as phase control and inverter types. The thyristors have been widely used in dc and ac drives, lighting, heating and welding control.

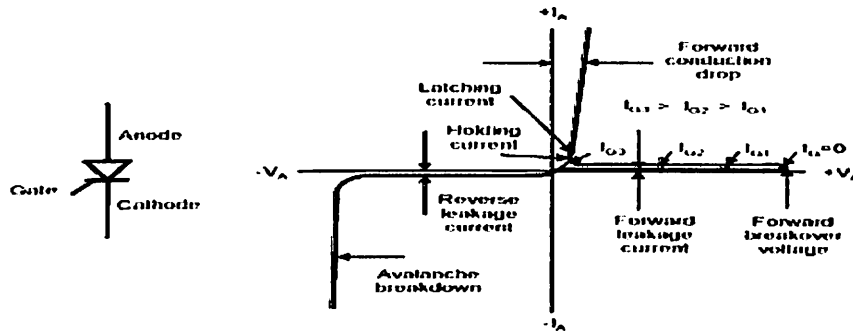

Figure 2.3: Thyristor

2.2.2 MOSFET

Power MOSFET (Metal Oxide Semiconductor Field Effect Transistor) are the most commonly used in converter due to their low gate driver power, fast switching action and superior paralleling capability. A power MOSFET is a voltage controller device that requires only a small input current to operate and it is designed to handle a large amount of power. Power MOSFET can be divided into two type which is n-channel MOSFET and p-channel MOSFET and each of it available in either enhancement-mode or depletion mode . Because a depletion MOSFET remain on at zero voltage meanwhile enhancement MOSFET remain off at zero voltage so the enhancement MOSFET are generally used as switching device in power electronic. A power MOSFET contains three terminals which are drain (D), gate (G), and source(S).

Power MOSFET operate under two different modes the first quadrant operation and the third quadrant operation. First quadrant operation for an n-channel MOSFET the device operates in the first quadrant when a positive voltage is applied to drain and third quadrant operation for power MOSFET is normally used in DC-DC buck converter where current conduction occurs under at voltage drain to source. A power MOSFET is an important component in DC-DC converter as it is responsible for the on-off switching in the circuit.

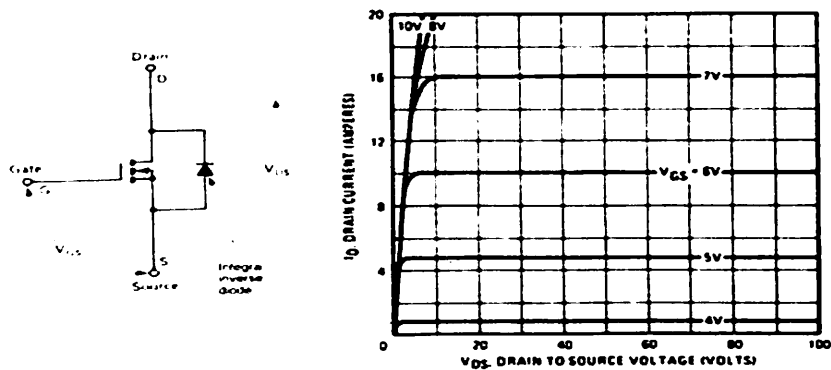

Figure 2.4: MOSFET

2.2.3 IGBT

An insulated-gate bipolar transistor (IGBT) is a three-terminal power semiconductor device primarily used as an electronic switch which, as it was developed, came to combine high efficiency and fast switching. It switches electric power in many modern appliances: variable-frequency drives (VFDs), electric cars, trains, variable speed refrigerators, lamp ballasts, air-conditioners and even stereo systems with switching amplifiers. Since it is designed to turn on and off rapidly, amplifiers that use it often synthesize complex waveforms with pulse-width modulation and low-pass filters. In switching applications modern devices feature pulse repetition rates well into the ultrasonic range—frequencies which are at least ten times the highest audio frequency handled by the device when used as an analog audio amplifier.

The IGBT combines the simple gate-drive characteristics of MOSFETs with the high-current and low-saturation-voltage capability of bipolar transistors. The IGBT combines an insulated-gate FET for the control input and a bipolar power transistor as a switch in a single device. The IGBT is used in medium- to high-power applications like switched-mode power supplies, traction motor control

and induction heating. Large IGBT modules typically consist of many devices in parallel and can have very high current-handling capabilities in the order of hundreds of amperes with blocking voltages of 6000 V, equating to powers of hundreds of kilowatts.

2.3 PWM Principle

Pulse width modulation control works by switching the supply to the motor using MOSFET on and off very quickly. The DC voltage output to the gate of MOSFET is converted to a square wave signal.

Pulse width modulation technique (PWM) is a technique for speed control which can overcome the problem of poor starting performance of a motor. It also has the advantage in that the power loss in the switching transistor is small because the transistor is either fully "ON" or fully "OFF". As a result the switching transistor MOSFET has a much reduced power dissipation giving it a linear type of control which results in better speed stability. Instead of supplying a varying voltage to a motor, it is supplied with a fixed voltage value (almost 12v) which rotate motor immediately. Besides that the amplitude of the motor voltage remains constant so the motor is almost always at full strength. The result is that the motor can be rotated much more slowly without it stalling.

The waveforms in figure 2.5 explain how duty cycle is varies to control dc motor speed. In each case the signal has maximum and minimum voltage between 12v and 0v.

By varying duty cycle over the full range, it is possible to obtain any desired average output voltage from 0v to 12v. The motor will work perfectly well, provided that the frequency of the pulsed signal is set correctly, a suitable frequency being 30 Hz setting the frequency too low.