



UNIVERSITI TEKNIKAL MALAYSIA MELAKA

DESIGN AN INTERLEAVED BUCK CONVERTER

This report submitted in accordance with requirement of the UniversitiTeknikal
Malaysia Melaka (UTeM) for the Bachelor Degree Project in Electrical
Engineering Technology
(Industrial Power) (Hons.)

Submitted by

**MOHAMED IZHAM HAFIZ BIN MOHAMED@ASARI
B071210355**

Supervised by

SyahrulHisham Bin Mohamad

**FACULTY OF ENGINEERING TECHNOLOGY
2015**

BORANG PENGESAHAN STATUS LAPORAN PROJEK SARJANA MUDA

TAJUK: **DESIGN AN INTERLEAVED BUCK CONVERTER**

SESI PENGAJIAN: **2014/15 Semester 2**

Saya **MOHAMED IZHAM HAFIZ BIN MOHAMED@ASARI**

mengakumembenarkan Laporan PSM ini disimpan di Perpustakaan Universiti Teknikal Malaysia Melaka (UTeM) dengan syarat-syarat kegunaan seperti berikut:

1. Laporan PSM adalah hak milik Universiti Teknikal Malaysia Melaka dan penulis.
2. Perpustakaan Universiti Teknikal Malaysia Melaka dibenarkan membuat salinan untuk tujuan pengajian sahaja dengan izin penulis.
3. Perpustakaan dibenarkan membuat salinan laporan PSM ini sebagai bahan pertukaran antara institusi pengajian tinggi.
4. ****Silatandakan (✓)**

SULIT

(Mengandungi maklumat TERHAD yang telah ditentukan oleh organisasi/badan di mana penyelidikan dijalankan)

TERHAD

(Mengandungi maklumat yang

berdarjah keselamatan atau kepentingan Malaysia sebagaimana yang termaktub dalam AKTA RAHSIA RASMI 1972)

TIDAK TERHAD

Disahkan oleh:

(TANDATANGAN PENULIS)

Alamat Tetap:

NO. 916 Jalan Kenari 15

Kampung Baru

Kuala Lumpur,

(TANDATANGAN PENYELIA)

Cop Rasmi

SYAHRUL HISHAM BIN MOHAMAD @ ABD RAHMAN
Pensyarah
Jabatan Teknologi Kejuruteraan Elektrik
Fakulti Teknologi Kejuruteraan
Universiti Teknikal Malaysia Melaka

****** Jika Laporan PSM ini **SULIT** atau **TERHAD**, sila lampirkan surat daripada pihak berkuasa/organisasi berkenaan dengan menyatakan sekali-sekala dan tempoh laporan PSM ini perludikelaskan sebagai **SULIT** atau **TERHAD**.

DECLARATION

I hereby, declared this report entitled “Design an Interleaved Buck Converter” is the results of my own research except as cited in references.

Signature :.....

Name :**MOHAMED IZHAM HAFIZ BIN
MOHAMED@ASARI**

Date :

APPROVAL

This report is submitted to the Faculty of Engineering Technology of UTeM as a partial fulfillment of the requirements for the degree of Bachelor of Engineering Technology (Type your department's name here) (Hons.). The member of the supervisory is as follow:

.....
(Project Supervisor)

ABSTRACT

The report project of this DC-DC Interleaved Buck Converter is a research project to use the application which based on the nowadays scenario in monitoring and evaluating progress of Bachelor Degree Project 1. This report is highlight the observation and research phase project. To get the highest control of performance of a dc-dc converter , a good converter is critical. The load also critical to give the affects on taking the consideration as part of the converter. The load is often use as the component that give a variable outcome of this system. A DC-DC interleaved buck converter was taken in this project because of its ability to step down the high input voltage to a low output voltage the better. The proposed of this project is presented with a soft-switching techniques using a MOSFETT. A DC-DC interleaved buck converter is a DC-DC power converter that converts DC voltage to a step down DC voltage. The converter is consisting of a capacitor, inductor, diode and an inductor. In this report, we analyze the equations of a DC-DC interleaved buck converter and proposed a design component that is suitable for this project. The simulation studies will be carried out in MATLAB, OrCAD and Multisim software. The experimental results for interleaved buck converter obtained in theoretical, software and hardware will be compared. The process of monitoring project progress is conducted by the lecturer which entitled as a project supervisor.

ABSTRAK

Projek laporan ini DC-DC Interleaved Buck Converter adalah satu projek penyelidikan untuk menggunakan aplikasi yang berdasarkan senario pada masa kini dalam memantau dan menilai kemajuan daripada Projek Sarjana Muda 1. Laporan ini menyerlahkan projek fasa pemerhatian dan penyelidikan. Untukmendapatkankawalan yang paling tinggi prestasi penukar dc-dc, penukar yang baik adalah kritikal. Beban juga penting untuk memberi kesan kepada untuk mengambil kira sebagai ebahagian daripada penukar. Beban ini sering digunakan sebagai komponen yang memberikan hasil yang berubah-ubah sistem ini. DC-DC buck interleaved penukar telah diambil dalam projek ini kerana keupayaannya untuk berundu r voltan masukan yang tinggi kepada avoltan keluaran yang rendah yang lebih baik itu. Cadangan projek ini disampaikan dengan lembut-menukar teknik menggunakan MOSFETT. DC-DC buck interleaved penukar adalah penukar kuasa DC-DC yang menukarkan voltan DC kepada langkah kebawah voltan DC. Penukar in terdiri daripada kapasitor, induktor, diod dan pengaruh. Dalam laporan ini, kita menganalisis persamaan DC-DC buck interleaved penukar dan mencadangkan satu komponen reka bentuk yang sesuai untuk projek ini. Kajian simulasi akan dijalankan dalam MATLAB, OrCAD dan perisian Multisim. Keputusan eksperimen untuk penukar buck interleaved diperolehi dalam teori, perisian dan perkakasan akan dibandingkan. Proses kemajuan projek pemantauan dijalankan oleh pensyarah yang berhak sebagai penyelia projek.

DEDICATIONS

To my beloved mama that work hard to take care of me, I want to say thanks and I love you mama. To my late father you always in my prayer. Special thanks to my supervisor Mr.SyahrulHisham that trust in me and guide me to make this report and my housemate Peng, Don, Raja ,Nik, Sam, Choi ,Musid, Yap, Ayie and Ainol that always helping me.

ACKNOWLEDGMENTS

First of all, I would like to thank to my supervisor, Mr SyahrulHisham Bin Mohamad for his guidance during my work and for comments on the thesis of this project. Thanks also to PuanEmyZairah for reading and commenting this project report.

Furthermore, I would like to thank to my classmates for discussions about practical problems with designing a DC-DC interleaved buck converters and for helping me with measurements.

I would also like to thank to the staff at the Faculty of Engineering Technology, UniversitiTeknikal Malaysia Melaka, and the staff at the Department of Electrical Engineering Technology (Industrial Power) specifically, who have helped me in many ways.

Finally, I would like to thank my parents, my family and my housemate for giving me their full support, understanding and patience. Without their support, I would not have been able to finish my bachelor degree research project.

TABLE OF CONTENTS

DECLARATION	iv
APPROVAL.....	v
ABSTRACT.....	vi
ABSTRAK	vii
DEDICATIONS.....	viii
ACKNOWLEDGMENTS	ix
TABLE OF CONTENTS.....	x
LIST OF FIGURES	xiii
LIST OF TABLE	xiv
LIST OF SYMBOLS AND ABBREVIATIONS	xv
CHAPTER 1	1
1.0 Background	1
1.1 Problem Statement	1
1.2 Objectives.....	2
1.3 Work Scope.....	2
CHAPTER 2	3
2.0 Introduction	3
2.1 Chopper Electronics	4
2.1.1 Related Work on Chopper.....	6
2.2 Buck Converter.....	7

2.2.1	Related Work on Buck Converter	7
2.3	Boost Converter.....	8
2.3.1	Related Work on Boost Converter	9
2.4	Buck Boost Converter	10
2.4.1	Related Work on Buck Boost Converter.....	11
2.5	Interleaved Buck Converter.....	12
2.5.1	Related Work on Interleaved Buck Converter	12
CHAPTER 3	13
3.0	Introduction	13
3.1	Designing a DC-DC Interleaved Buck Converter	15
3.2	Selection of Switching Device	17
3.3	Selection of Inductor	19
3.4	Selection of Diode	19
3.5	Selection of Capacitor	20
3.6	Simulation of the DC-DC Interleaved Buck Converter	21
3.7	Calculation Involved In designing a DC-DC Interleaved Buck Converter	23
3.8	Hardware Project Implementation.....	24
CHAPTER 4	26
4.0	Introduction	26
4.1	Development of Designing Interleaved Buck converter	26
4.1.1	Designing Interleaved Buck converter Circuit.....	26
4.1.1.1	Calculation Designing The interleaved Buck Converter	28
4.1.2	Designing The Driver Circuit.....	30

4.1.3	Designing The PWM Circuit	32
CHAPTER 5		33
5.0	Introduction	33
5.1	Conclusion.....	33
5.2	Problem Faced.....	34
5.3	Suggestion for Future Work	34
REFERENCES.....		35

LIST OF FIGURES

Figure 2.1: Basic schematic design of buck converter.....	7
Figure 2.2 :Basic Scematic Circuit Boost Converter	8
Figure 2.3New isolated interleaved boost converter.....	9
Figure 2.4: Schematic Design Buck-boost Converter.....	10
Figure 2.5: New Buck-boost DC to DC Converter of High Efficiency	11
Figure 2.6: Schematic design of interleaved buck converter	12
Figure 3.1: The project flow chart.....	14
Figure 3.2: Conventional Design of Interleaved Buck Converter.....	15
Figure 3.3: Circuit Configuration of ZVS Converter.....	16
Figure 3.4: Symbol of IGBT	17
Figure 3.5: Symbol of MOSFET.....	18
Figure 3.6: Symbol of Diode.....	20
Figure 3.7: Simulink Library Browser	22
Figure 3.8: Circuit Configuration of Interleaved Buck Converter	22
Figure 3.9: Output Waveform of Interleaved Buck Converter	23
Figure 3.10: Etching Result of IBC Circuit	25
Figure 3.11: Etching Result of Driver Gate Circuit	25
Figure 4.1: Hardware of Interleaved Buck Converter Circuit.....	27
Figure 4.2: Hardware of Driver Gate Circuit.....	31
Figure 4.3: Output Wave of Driver Gate Circuit	31
Figure 4.4: Hardware of PWM Circuit	32
Figure 4.5: Output Wave of PWM Circuit.....	32

LIST OF TABLE

table 2.1: Comparison between Chopper	5
Table 4.1: Component Use in IBC Circuit.....	27
Table 4.2: Parameter for Calculation.....	28

CHAPTER 1

INTRODUCTION

1.0 Background

An interleaved buck converter is a converter designed in order to reduce the stress within the component inside a buck converter. A buck converter is a voltage step-down and a current step-up. This interleaved buck converter will focus on waveform and ripple output. The main focus of this project is to design and construct a DC to DC converter (buck type) which is the main part in this interleaved buck converter. An interleaved buck converter is designed to reduce the stress of the filtering components and reduce ripple output. This project consists of three main approaches of a development process that are designed, simulate and construct.

1.1 Problem Statement

In the current scenario nowadays, DC-DC converter acted as important role in industrial areas. This interleaved buck converter is not widely used in this current century because it is still new in this industry. If we make an experiment or testing something that need to check on the waveform or ripple output and sometimes the waveform or that ripple output will produce a noise that make us hard to read it accurately. This interleaved buck converter will reduce the noise or the stress of that waveform and ripple output so we can read it more accurately. That's why we use this buck converter

1.2 Objectives

The main purpose of the project is to develop DC-DC Buck Converter that converts the unregulated DC input to a controlled DC output with desired voltage level. Furthermore, the objectives are to:

- a) To study and design a multiple layer of the Interleaved Buck Converter.
- b) To simulate the design of multilayer Interleaved Buck Converter.
- c) To fabricate and conduct experimental work to study of the efficiency of the Interleaved Buck Converter.

1.3 Work Scope

The works undertaken in this project are limited to, the following aspects:

- a) To study and design an Interleaved Buck Converter based on a multiple layer design for voltage input 12V to 24V.
- b) To simulate the Interleaved Buck Converter design by using multisim software, pspice software and Matlab software
- c) To fabricate and conduct the experimental work to test the efficiency of the Interleaved Buck Converter by using a different input voltage in order to study the buck characteristic

CHAPTER 2

LITERATURE REVIEW

2.0 Introduction

This section provides a previous study of related work regarding the application of chopper in a various fields. Some previous researches have been studied to gain more information about current existing chopper that was previously implemented. It is necessary to know and understand how the software and hardware were used in the chopper development. This is to ensure that the study that currently being conducted contribute at a certain level of application, thus it becomes more efficient and practical

2.1 Chopper Electronics

Chopper is a circuit that we used to refer to a lot of types of electronic switching devices and circuits that we used in power control and signal applications. This chopper is one of a switching devices that converts fixed DC input to a variable DC output voltage directly. We also can know this chopper as an electronic switch that used to interrupt or distract one signal under the control of another. This chopper usually used in power electronics application and the switching element is either fully on or fully off, its losses are low and the circuit can provide high efficiency. There is one problem which is the current that supplied to the load is not continuous and need smoothing or high switching frequency to overcome undesirable effects. This chopper also can use as a stabilizer in the signal processing circuit to avoid drifting of an electronics component. A synchronous demodulator can be used to recover the original signal after amplification or other processing by un-does "chopping" process. There are two types of chopper which is a step-down chopper and a step-up chopper. From that two type we can separate it into a few parts, for a step-down chopper it has four classes that is class A, class C, class D and class E but for step-up chopper there is only one class and that was class B. Below there is a table comparison between step-up and step-down chopper ;

table 2.1: Comparison between Chopper

no	Parameters	Step down chopper	Step up chopper
1	Range of output voltage	0 to V volts	0 to V volts
2	Position of chopper switch	In series with load	In parallel with load
3	Expression for output voltage	$V_L \text{ dc} = D \times V$ volts	$V_o = V / (1 - D)$ volts
4	External inductance	Not required	Required for boosting the output voltage
5	Use	For motoring operation, for motor load	For regenerative braking for motor load.
6	Type of chopper	Single quadrant	Single quadrant
7	Quadrant of operation	1st quadrant	1st quadrant
8	Applications	Motor speed control	Battery charging/voltage boosters

After that for the circuit operation on the basis there are three which is first quadrant, two quadrant and four quadrant, but for commutation method that is replacement method on the basis there are four and that is voltage commutated, current commutated, load commutated and impulse commutated. Most modern uses also use alternative nomenclature which helps to clarify which particular type of circuit is being discussed. These include switched mode power supplies that include DC to DC converters, speed controllers for DC motors, class D electronic amplifier and

switched capacitor filters. This chopper has a lot applications in electronics such as variable frequency drive, DC motor speed control, DC voltage boosting, battery operated electric cars, battery operated appliances and lastly the one that we always use is a battery charger. Chopper configuration is operating from a fixed DC input voltage and periodic opening and closing of the switches used in the chopper circuit can control the average value of the output voltage. Pulse with modulation technique, frequency modulation, variable frequency, variable pulse width and CLC control is a different technique that can control the average output voltage. One of the functions in chopper electronics that is still in use is in chopper amplifiers and it is a DC amplifiers.

2.1.1 Related Work on Chopper

JiaweiXu and QinwenFan. (2013) state that choppers are a continuous-time technique which is polarity-reversing switch that also known as chopping are used to modulate amplifier offset and $1/f$ noise to a certain chopping frequency. This journal presents a theoretical analysis and measurements of the current noise of several chopper instrumentation amplifiers which demonstrate that the charge injection and clock feed through associated with the MOSFETs of the input chopper give rise to significant input current and current noise. If this chopper combines with high source impedances it will convert to voltage noise which may then be a significant contributor to the amplifier's total input referred voltage noise. Chopper noise has a white power spectral density, whose magnitude is roughly proportional to the chopping frequency. This action enables the realization of precision amplifier with low voltage noise and low offset. This chopper amplifier are always used in many applications where precision signal conditioning is needed such as smart sensors, sensor interfaces, medical instruments and precision voltage references. The switches of chopper in CMOS usually apply as MOSFETs and well known for the transient spikes caused by the charged injection and clock feed through of these periodically switched devices will give rise to a net input current that not much is known about the associated current noise. The shot noise that corresponding with this input current is caused by the current noise of a chopper amplifier.

2.2 Buck Converter

A buck converter is a voltage step down and current step up converter. We use a linear regulator such as 7805 as a simplest way to reduce the voltage of a DC supply, but it wastes energy as they operate by dissipating excess power as heat. This buck can be so efficient like 95% or higher for integrated circuits by making them useful for tasks such as converting the main voltage of electrical devices. The basic design of a buck converter that it has the current in an inductor controlled by two switches and usually it was a transistor and a diode.

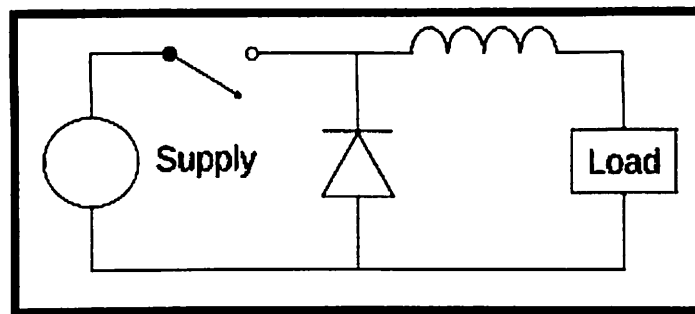

Figure 2.1: Basic schematic design of buck converter

2.2.1 Related Work on Buck Converter

According to B. Chittibabu, S.R. Samantaray and Nikhil Saraogi. (2011) synchronous buck converter based photo voltaic (PV) energy system for portable applications. This journal is about using buck converter and photovoltaic to charge batteries in mobile phones. The supremacy of using a synchronous buck converter is to lower the switching loss in the main MOSFET over ordinary DC-DC buck converter. They apply the techniques of soft switching such as zero-voltage switching(ZVS) and zero-current switching(ZCS) in the proposed converter to minimize the switching loss. Thus the cost effective solution is obtained especially in the design of the heat sink in the DC-DC converter circuit. The buck converter act as a converter of extracting the DC power from the PV energy system that have been synthesized and modulated. The idiosyncratic of the PV array is reviewed under

dissimilar values of temperature and solar radiation. The performance of buck converter is analyzed and compared with classical DC-DC buck converter in terms of switching loss reduction and improved converter efficiency.

2.3 Boost Converter

A boost converter is a step-up converter that is also a DC-DC power converter with an output voltage higher than its input voltage. It is a class of switched-mode power supply (SMPS) containing at least two semiconductors that are a diode and transistor and at least one energy storage element, a capacitor, an inductor or both. It can normally be added to the output of converters with the filters made of capacitors and sometimes in combination with inductors to lower the output voltage ripple.

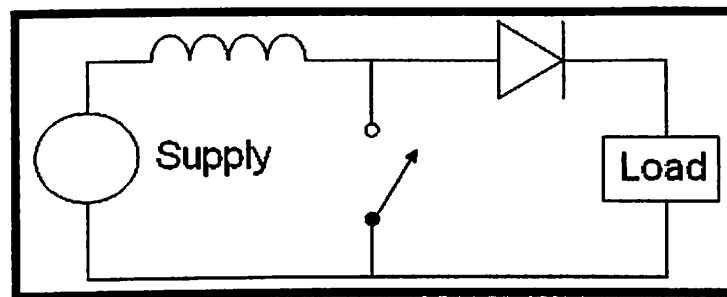

Figure 2.2 :Basic Schematic Circuit Boost Converter

This boost converter can get a power from any suitable kind of DC source such as battery, solar panels, rectifiers and DC generator. A process that changes one DC voltage to another DC voltage we can call it as DC to DC conversion. Boost converter is a DC to DC converter with an output voltage greater than the source voltage and sometimes called as a step-up converter since it steps up the source voltage. Since power ($P=VI$) must be conserved the output current is lower than the source current.

2.3.1 Related Work on Boost Converter

A new interleaved boost converter for high power application is wished for being in the low to high DC to DC application where isolation is needed or a large step up is in a need. According to Jun Wen, Taotao Jin and Keyue Smedley.(2005) the key and the dare to design such a converter for high power applications is you know how to handle the high current at the input and high voltage at the output. An effective way is to parallel the inputs and series the outputs of the isolated boost converters. According to this concept, a new interleaved and isolated boost converter is proposed in this paper that has two inductors in parallel at the input to share the current and two capacitors in series at the output to share the voltage. The voltage and current stresses of the converter are both reduced. Demagnetizing this two boost converter cells by helping each other can simplify the transformer structures. Why we use interleaved operation because we want to make the current ripple smaller so it is possible to use smaller capacitors at the input and output of the converter. All these features make the new interleaved isolated boost converter advantageous for high power low to high DC to DC applications. The proposed interleaved isolated boost converter is presented based on the basic isolated boost converter, but the interleaved structure is applicable to other isolated boost converters, including the full-bridge converter, the push-pull converter, and the L-type half-bridge converter. The theoretical analysis is verified by a 200W prototype.

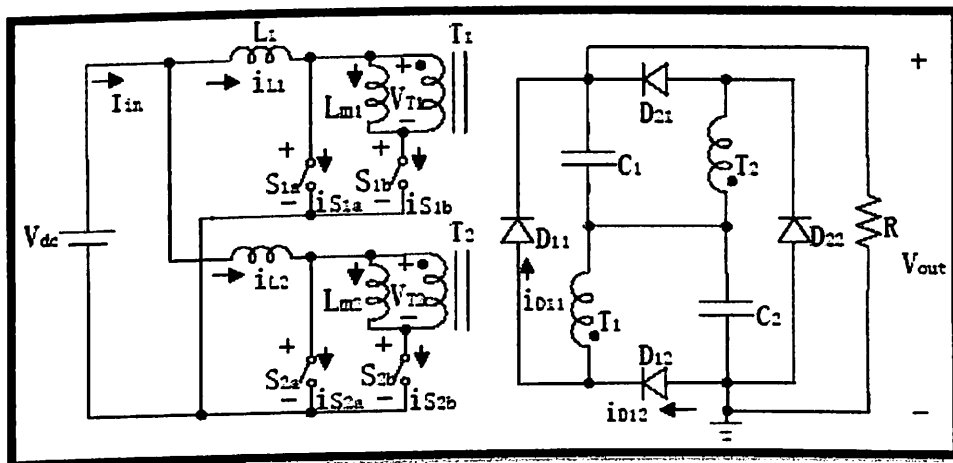

Figure 2.3 New isolated interleaved boost converter

2.4 Buck Boost Converter

This buck-boost converter also a DC-DC converter type same as buck converter and boost converter, but it has an output voltage magnitude that is either bigger than or lower than the input voltage magnitude. Flyback converter which using a single inductor instead of a transformer is a most likely type of converter that same with this buck-boost converter. Both of them can produce a range of output voltages, from an output voltage much larger that was in absolute magnitude than the input voltage, down to almost zero. If we explain this converter with the inverting topology the output voltage is of the opposite polarity than the input and that was called a switched-mode power supply with a similar circuit topology on the boost and buck converter. The advantage of this converter is its voltage is adjustable according to the duty cycle of the switching transistor. There is one possible disadvantage of this converter is that the switch does not have a terminal ground and that's complicates the driving circuitry. This converter actually a combination of buck and boost converter. The output voltage is typically of the same polarity of the input and can be lower or higher than the input. A non-inverting buck-boost converter can use a single inductor for both buck inductor and the boost inductor but it also can use a multiple inductor and only a single switch such as in the SEPIC and CUK topologies. Below is a schematic design for a buck-boost converter;

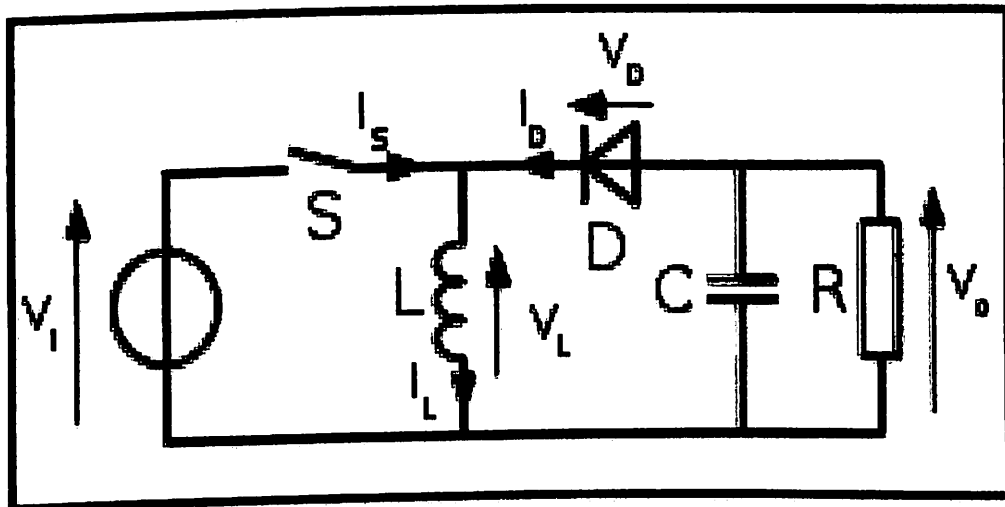

Figure 2.4: Schematic Design Buck-boost Converter