

PROFIL PENYELIDIKAN

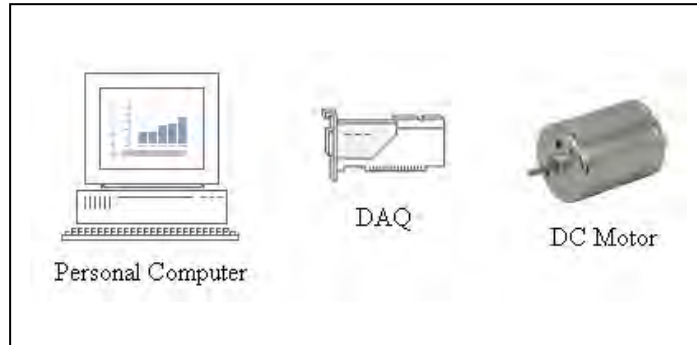

OBSTACLE AVOIDANCE FOR MOBILE ROBOT USING VISION SYSTEM

**Principal Researcher:
YUSMARNITA BINTI YUSOP**

**Co-researcher:
Siti Huzaimah binti Husin, Zulhairi bin Othman, Siva Kumar a/I Subramaniam**

UNIVERSITI TEKNIKAL MALAYSIA MELAKA

Email: yusmarnita@utem.edu.my

Fields: Power Electronics

ABSTRACT

Electric motors have been widely used in all sorts of application since the industrial revolution. The rotation and direction speed motors varies according to its application. Conventional method requires physical adjustment of the variable resistors to control the speed of the motor. However, such approach leads to great power loss and causes inefficiency within the designed system. Although a PWM controlled system is normally used to overcome the drawback of the conventional method; the duty cycle of the generated signal and the exact rotation speed of the motor could not be monitored and controlled. As a result, the reliability, efficiency and accuracy of the PWM signal technique is still unpredictable. This particular project is to develop a PC-based monitoring for DC motor speed control system. The developed system controls the PWM signal through the use of NI LabVIEW software and NI DAQ device (USB-6221) to monitor digitally and control the duty cycle as well as display the exact speed of the rotating motor. The accuracy and efficiency of the system can now be made relatively high. LabVIEW enables an intuitive graphical programming development environment for engineers to acquire, analyze and present real-time data. Real-time data can easily be obtained by interfacing the DAQ device with the LabVIEW software which suits various application purposes.

CHAPTER I

INTRODUCTION

1.1 Introduction

PC-based monitoring or controlling is emerging as a new control pattern for increasing manufacturing productivity. PC-based monitoring offers open and more intuitive traditional solutions at a lower total system cost and easier migration to future technologies. Easier development, integration, portability, and access ensure a flexible and efficient solution.

Industry analysts and major global manufacturers agree that PC-based control is the future. Today, PC-based monitoring is an integral part of industrial measurement and monitoring. The number continues to grow as industry leaders include PC-based solutions. It is important to understand PC-based monitoring and, more importantly, the benefits and challenges increased when committing to this next level of control technology.

Manufacturers around the world look to PCs to play a bigger role in their monitoring and controlling systems. PCs are already an accepted platform for system supervisory control, monitoring and reporting, as well as off-line data management and analysis. Manufacturers have already realized the flexibility of the PC and the easy-to-use open architecture of Windows-based software applications for the manufacturing environment.

In this project, the DC motor's speed is controlled by using the LabVIEW software package from the National Instrument by using PC. There are many methods that have been used to control the DC Motor's speed, the conventional method is by adjusting the supply voltage of the motor but this method is inefficient because the power losses is high. So, to solve this problem, Pulse Width Modulation (PWM) technique had been used to make the control of DC motor more efficient, it is called the hardware controlling technique. The PWM signal is generated by comparing a triangular of DC motor wave signal with a DC signal in the hardware controller technique. However the drawback still exists in the hardware controlling technique, whereby the exact speed is unknown. As a result, PC-based system to generate the PWM signal overcomes the drawback of the hardware controlling technique. PWM signal can easily be generated with the combination of LabVIEW software and DAQ data acquisition device. In this project the LabVIEW block diagram will be created and the Virtual Instrument (VI) front panel will be developed to generate the PWM signal. Virtual Instrument (VI) front panel will perform the following function such as generating, displaying, and measuring the PWM signal. Despite of that, it also can be used to perform other functions such as displaying the detected speed and controlling the direction of the motor.

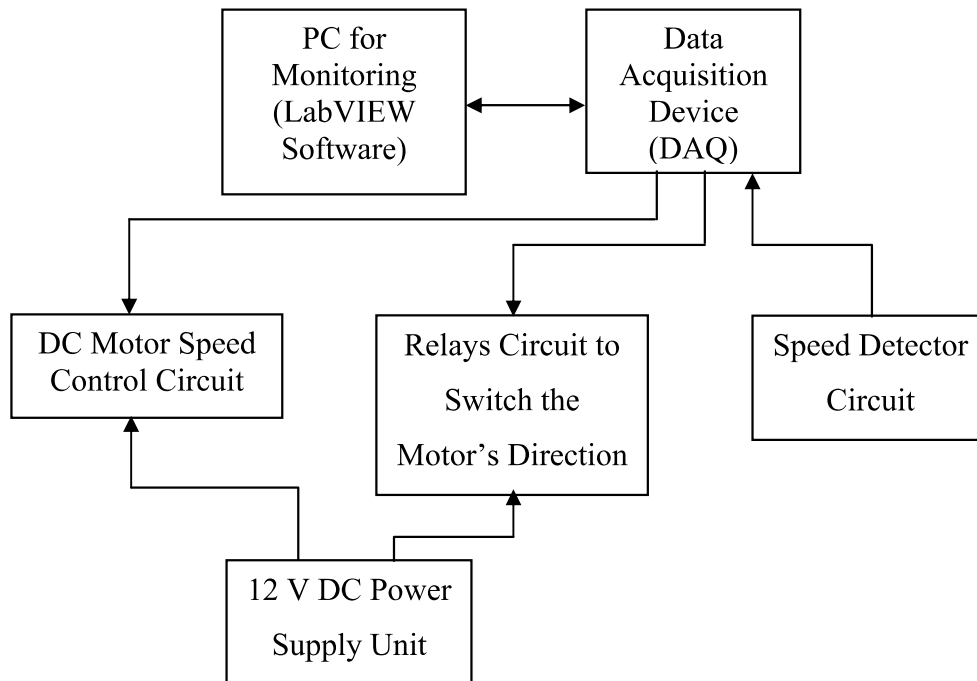

Figure 1.1: Block Diagram of Project

The general idea of the project can be described based in Figure 1.1. A PC with the installed NI LabVIEW software for monitoring and controlling is used to interface with the DC motor speed control circuit, speed detector circuit, and relays circuit for motor's direction switching, voltage divider signal conditioning circuit for measuring the 12V DC voltage by using the NI USB-6221 DAQ device. The PWM signal can be generated with the combination of the PC and DAQ device. Duty Cycle is used to vary the width of the turn ON time, "Ton" for the generated PWM signal. The speed in RPM can be measured and displayed on the Virtual Instrument front panel.

1.2 Project's Objectives

There are several objectives that need to be achieved at the end of PSM. The objectives are listed as below:

- i. To produce a DC motor's speed monitoring and controlling system by using the PC-based technique with LabVIEW software instead of conventional and hardware techniques.
- ii. To overcome the drawbacks of DC motor's speed controlling that uses the conventional and hardware techniques.
- iii. To ease the users in monitoring and controlling the speed of DC motor by using the PC instead of physical or conventional controlling. In another words; to create a user friendly interface of Virtual Instrument which can be used to control the speed of a DC motor

1.3 Problem Statement

1.3.1 The Conventional Method

The physical adjustment of voltage by using the variable resistor to control the motor's speed will lead to high power losses or in other words it is not efficient. For instant, in order to get 50% of DC motor's speed by using a resistive controller, the power would consume about 71% of full power where 50% of the power goes to the loads and the other 21% is wasted heating in the series resistor [2].

1.3.2 Hardware Controller to Generate the PWM Signal

PWM signal is generated by using the hardware controller method overcomes the conventional method where almost full power will be used and transferred to the load which means 50% of full power will be used up for 50% of dc motor's speed. However, the problems do occur whereby the duty cycle can not be monitored and displayed and the exact speed is unknown, hence the prediction of the speed by controlling the triangle signal or the DC level signal is needed. As a result, the efficiency and accuracy levels still low [2].

1.3.3 PC-based With PWM Technique

PC-based using LabVIEW software with PWM method overcomes the hardware controlling method where full power will be delivered to load, duty cycle can be monitored and displayed and the exact speed is known, as a result, the prediction of speed not required.

1.4 Scopes of Work

The scope of work in this project is stated as given:

- i. PC-based monitoring
- ii. LabVIEW Software
- iii. Data Acquisition (DAQ) device
- iv. Generating PWM signal
- v. Controlling the DC motor's speed
- vi. Controlling the motor's direction
- vii. Detecting the motor's speed
- viii. Develop 12VDC Power Supply Circuit

- ix. Develop 12VDC Motor speed Controller
- x. Develop motor's speed detector circuit
- xi. Develop motor's directional switching circuit

1.5 Report Structure

This thesis is a documented report of the ideas generated, the theories and concepts applied, the activities performed and the final product of this project produced. The thesis consists of five chapters and each chapter is described as below:

Chapter 1, the introduction of PC-based monitoring and describing the technique used to control the speed of the DC Motor. The block diagram gave the general ideas on this project. In addition, objectives, problem statement of the project and the report structure is included as well.

Chapter 2, the background study of the project along with the literature review is performed and documented about the theoretical concept applied in completing the project. Background study on the PC-based monitoring system, LabVIEW software, PWM signal, Duty Cycle, DC Motors, Power Switching component (MOSFET), DC motor speed controller are carried throughout this project.

Chapter 3 is the introduction of methodology for the project, design flow and construction of the project. Brief description is given about each procedure in the completion of the project.

Chapter 4 shows overall result and discussion of the result as well as the comparison with the conventional method. Hardware prototyping and the developed LabVIEW Virtual Instrument front panels, the created LabVIEW block diagrams about the project are shown in order to strengthen the result.

Chapter 5 is the final part of the thesis which concludes the Final Year Project. This chapter includes the application of the project and the recommendation that can be implemented for future references.

CHAPTER II

LITERATURE REVIEW

2.1 Introduction

PC-based monitoring technique is a very common in the recent technology. The examples of the PC-based monitoring are Industrial Measurement and Monitoring, Remote Surveillance for TC/IP, Mobile Surveillance System, Monitoring the Speed of the Motors, and etc.

There are many types of software or programming language which can be used to program for monitoring purposes. However, National Instrument LabVIEW software is selected in this project, the reason of selecting the LabVIEW software in this project is because it is graphical programming language unlike the text based programming languages like C, Basic and etc.

NI LabVIEW software can be used to acquire, analyze, and present the data obtained from the input or output devices. Data can be acquired through the interfacing of DAQ device. For example the speed of the DC Motor can be controlled by sending the data from the Virtual Instrument Front Panel to the output circuit.

Pulse Width Modulation (PWM) technique is selected to use in this project in order to control the speed of the DC Motor.

2.2 National Instrument LabVIEW Software

National Instrument LabVIEW is the graphical development for creating flexible and scalable test, measurement, and control applications rapidly and at minimal cost. By using the LabVIEW, engineers and scientists interface with the real world signals, analyze data for meaningful information, and share results and applications. The combination of LabVIEW graphical development environment with NI-DAQmx gives the tools that needed to easily construct application using counters to generate the PWM signals.

LabVIEW is the vital part of the Virtual Instrumentation which provides a user-friendly application development environment designed specifically with the needs of engineers and scientists in mind. LabVIEW offers powerful features that make it easy to connect to a wide variety of hardware other software.

2.2.1 Graphical Programming

Graphical programming environment is one of the most powerful features that offered by the LabVIEW where user can design the custom Virtual Instruments by creating a graphical user interface environment to display on the screen of PC. With GUI environment, user can operate the instrumentation program, control the selected hardware, analyze the acquire data and display the results on the screen of PC.

Besides that, parameters front panels with the knobs, buttons, dials, and graphs which emulate the control panels of the traditional instruments, create custom test panels. These visually represent the control and operation of processes. The similarity in between the standard flow charts and graphical programs shorten the learning curve that associated with traditional and text-based programming languages.

Figure 2.1 and Figure 2.2 show the examples of developed VI front panel and the block diagram.

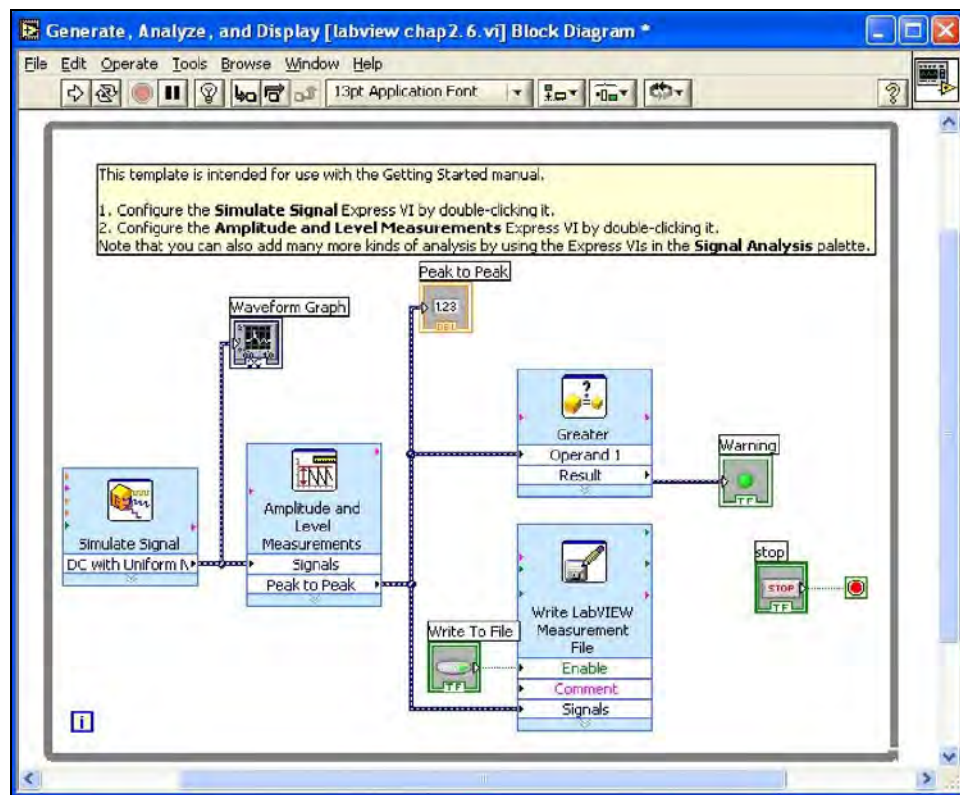

Figure 2.1: NI LabVIEW Virtual Instrument Block Diagram

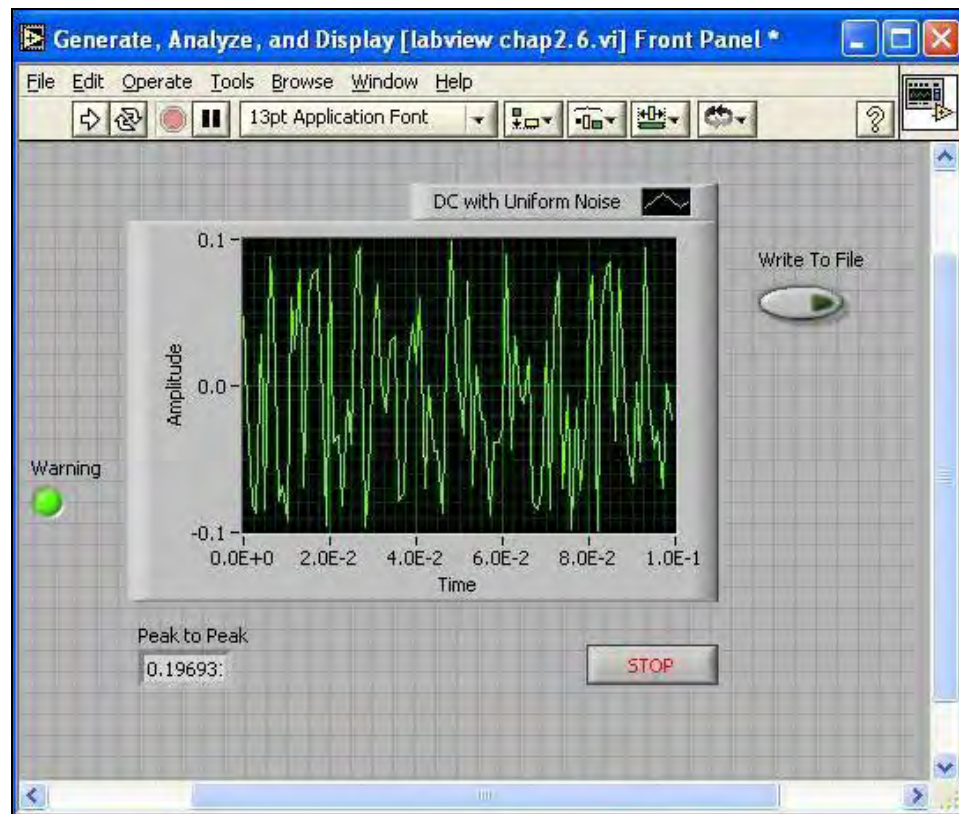

Figure 2.2: NI LabVIEW Virtual Instrument Front Panel

User can determine the behavior of the Virtual Instruments by connecting icons together to create block diagrams block diagrams, which are natural design notations for scientists and engineers. With graphical programming environment, user can develop systems more rapidly than with conventional programming languages, while retaining the power and flexibility needed to create a variety of applications [1].

2.2.2 Connectivity and Instrument Control

Virtual instrumentation software productivity comes about because the software includes built-in knowledge of hardware integration. Designed to create, test, measurement, and control systems, virtual instrument software includes extensive functionality for I/O of almost any kind [1].

2.2.3 Reduces Cost and Preserves Investment

With LabVIEW software user can use single computer equipment with LabVIEW for countless applications and purposes, it is a versatile product. It is not only versatile but also cost effective. Virtual Instrumentation with LabVIEW proves to be economical, not only in the reduced development costs but also in its preservation of capital investment over a long period time. As user needs change, user can modify systems easily without the need to buy new equipment of a single traditional, commercial instrument [1].

2.2.4 Multiple Platforms

The majority of computer systems use some variation of Microsoft Windows operating system. Nevertheless, options offer clear advantages for certain types of applications. Real-time and embedded development continues to grow rapidly in most industries, as computing power is packaged into smaller and more specialized packages. Minimizing losses resulting from changing to new platforms is important and choosing the right software for this purpose is a key factor. LabVIEW minimizes this concern, because it runs on Windows 2000, NT, XP, ME, 98, 95, and NT embedded, as well as Mac OS, Sun Solaris, and Linux. LabVIEW also complies code to run on the VenturCom ETS real-time operating system through the LabVIEW Real-Time Module. Given the important of legacy systems, National Instruments continues to make available older versions of LabVIEW for Windows, Mac OS, and Sun operating systems. LabVIEW is platform independent; virtual instruments that been written in one platform can transparently be ported to any other LabVIEW

platform by simply opening the virtual instrument. This is because LabVIEW applications are portable across platforms; user can be assured that what work today will be applicable in the future. As new computer technologies emerge, user can easily migrate the applications to new platforms and operating systems. In addition, it is because that user can create platform-independent virtual instruments by porting applications between platforms, so it can save development time and other inconveniences related to platform portability [1].

2.2.5 Analysis Capabilities

Virtual instrumentation software requires comprehensive analysis and signal processing tools; it is because the application does not just stop when the data is collected. High speed measurement applications in machine monitoring and control systems usually require order analysis for accurate vibration data. Closed-loop, embedded control systems might need point-by-point averaging for control algorithms to maintain stability. In addition to the advanced analysis libraries already included in LabVIEW, National Toolset, the LabVIEW Sound and Vibration Toolkit, and the LabVIEW Order Analysis Toolkit to complement offerings [1].

2.2.6 Visualization Capabilities

LabVIEW includes a wide array of built-in visualization tools to present data on the user interface of the Virtual Instrument for charting and graphing as well as 2D and 3D visualization. User can instantly reconfigure attributes of the data presentation, such as colours, font size, graph types, and more, as well as dynamically rotate, zoom, and pan these graphs with the mouse. Rather than programming graphics and all custom attributes from scratch, user can simple drag-and-drop these objects onto the instrument front panel [1].

2.2.7 Flexibility and Scalability

Engineers and scientists have needs and requirements that can use for a long time. By creating Virtual Instruments based on powerful development software such as LabVIEW, user can design an open framework that seamlessly integrates software and hardware. This ensures that the applications not only work well today but the user can easily integrate new technologies in the future as they become available, or extend their solutions beyond the original scope, as new requirements are identified. Moreover, every application has its own unique requirements that require a broad range of solutions. Virtual Instruments provide significant advantages in every stage of the engineering process, from research and design to manufacturing test [1].

2.2.8 Research and Design

In research and design, engineers and scientists demand rapid development and prototyping capabilities, with virtual instruments, user can quickly develop a program, take measurements from an instrument to test a prototype, and analyze results, all in a fraction of the time required to build tests with traditional instruments. When user need flexibility, an scalable open platform is essential, from desktop, to embedded systems, to distributed networks. The demanding requirements of research and development (R&D) applications require seamless software and hardware integration. Whether need to interface stand-alone instruments using GPIB or directly acquire signals into the computer with a data acquisition board and signal conditioning hardware, LabVIEW makes integration simple. With virtual instruments, user also can automate a testing procedure, eliminating the possibility of human error and ensuring the consistency of the results by not introducing unknown or unexpected variables [1].

2.2.9 Development Test and Validation

With the flexibility and power of virtual instruments, user can easily build complex test procedures. For automated design verification testing, you can create test routines in LabVIEW and integrate software such as National Instruments Test Stand, which offers powerful test management capabilities. One of the many advantages these tools offer across the organization is code reuse. User can develop code in the design process, and then plug these same programs into functional tools for validation, test, or manufacturing [1].

2.2.10 Manufacturing Test

Decreasing test time and simplifying development of test procedures are primary goals in manufacturing test. Virtual instruments based on LabVIEW combined with powerful test management software such as Test Stand deliver high performance to meet those needs. These tools meet rigorous throughput requirements with a high speed, multithreaded engine for running multiple test sequences in parallel. Test Stand easily manages test sequencing, execution, and reporting based on routines written in LabVIEW. Test Stand also can reuse code created in R&D or design and validation. If users have manufacturing test applications, users can take full advantage of the work already done in the product life cycle [1].

2.2.11 Manufacturing

Manufacturing applications require software to be reliable, high in performance, and interoperable. Virtual instruments based on LabVIEW offer all these advantages, by integrating features such as alarm management, historical data trending, security, networking, industrial I/O, and enterprise connectivity. With this functionality, user can easily connect to many types of industrial devices such as PLCs, industrial networks, distributed I/O, and plug-in data acquisition boards. By sharing code across the enterprise, manufacturing can use the same LabVIEW

applications developed in R&D or validation, and integrate seamlessly with manufacturing test process [1].

2.3 Data Acquisition

Data acquisition is the sampling of the real world to generate data that can be manipulated by a computer. Sometimes abbreviated DAQ or DAS, data acquisition typically involves acquisition of signals and waveforms and processing the signals to obtain desired information. The components of data acquisition systems include appropriate sensors that convert any measurement parameter to an electrical signal, which is acquired by data acquisition hardware.

Acquired data is displayed, analyzed, and stored on a computer, either using vendor supplied software, or custom displays and control can be developed using various text-based programming languages such as BASIC, C, FORTRAN, Java, Lisp, and Pascal. EPIC is used to build large scale data acquisition systems. LabVIEW offers a graphical programming environment optimized for data acquisition.

2.3.1 Data Acquisition Device (NI-USB-6221)



Figure 2.3: NI-USB-6221 DAQ device

The DAQ device which will be used in this project is NI USB-6221 from National Instrument, the overview and applications of this DAQ device can be described in the following paragraphs.

With recent bandwidth improvements and new innovations from National Instruments, USB has evolved into a core bus of choice for measurement and automation applications. National Instruments USB M Series devices deliver high-performance data acquisition in an easy-to-use and portable form factor through USB ports on laptop computers and other portable computing platforms. NI designed a new and innovative patent-pending NI signal streaming technology that enables sustained bidirectional high-speed data streams on USB. The new technology, combined with advanced external synchronization and isolation, helps engineers and scientists achieve high-performance applications on USB. NI USB M Series high-performance multifunction data acquisition (DAQ) modules are optimized for superior accuracy at fast sampling rates. They provide an onboard NI-PGIA 2 amplifier designed for fast settling times at high scanning rates, ensuring 16-bit accuracy even when measuring all available channels at maximum speed.

All high-performance devices have a minimum of 16 analog inputs, 24 digital I/O lines, seven programmable input ranges, analog and digital triggering, and two counter/timers. High-speed NI USB-625x and NI USB-622x M Series devices have

two-year and one-year calibration intervals, respectively. USB M Series devices are ideal for test, control, and design applications including:

- i. Portable data logging – log environmental or voltage data quickly and easily.
- ii. Field-monitoring applications.
- iii. Embedded OEM applications.
- iv. In-vehicle data acquisition.
- v. Academic lab use – academic discounts available.

2.4 PWM Techniques To Control The Speed Of DC Motor

Pulse Width Modulation (PWM) signal can be generated by using the hardware controller method and PC-based method.

2.4.1 Hardware Controller Technique

2.4.1.1 Introduction

12V and 24 V applications of Pulse Width Modulator can be described based on the circuit of Figure 2.4 which was featured in an article [2] in Home Power Magazine #75 (C) G. Forrest Cook 1999.

A Pulse Width Modulator (PWM) is a device that can be used as an efficient light dimmer or DC motor speed controller. The circuit of Figure 2.4 described a general purpose device that can be used to control DC devices which draw up to a few amps of current. The circuit can be used in either 12V or 24 V systems with only a few minor wiring changes. This device has been used to control the brightness of an automotive tail lamp and as a motor speed control for small DC fans of the type used in computer power supplies.

A PWM circuit works by making a square wave with a variable ON-to-OFF ratio, the average on time may be varied from 0 to 100 percent. In this manner, a variable amount of power is transferred to the load. The main advantage of a PWM circuit over a resistive power controller is the efficiency, at a 50% level, the PWM will use about 50% of full power, almost all of which is transferred to the load, a resistive controller at 50% load power would consume about 71% of full power, 50% of the power goes to the load and the other 21% is wasted heating the series resistor. Load efficiency is almost always a critical factor in solar powered and other alternative energy systems.

An additional advantage of pulse width modulation is that the pulses reach the full supply voltage and will produce more torque in a motor by being able to overcome the internal motor resistances more easily. Finally, in a PWM circuit, common small potentiometers may be used to control a wide variety of loads whereas large and expensive high power variable resistors are needed for resistive controllers.

The main Disadvantages of PWM circuits are the added complexity and the possibility of generating radio frequency interference (RFI). RFI may be minimized by locating the controller near the load, using short leads, and in some cases, using additional filtering on the power supply leads. This circuit has some RFI bypassing and produced minimal interference with an AM radio that was located under a foot away. If additional filtering is needed, a car radio line choke may be placed in series with the DC power input, be sure not to exceed the current rating of the choke. The majority of the RFI will come from the high current path involving the power source, the load, and the switching FET, Q1.

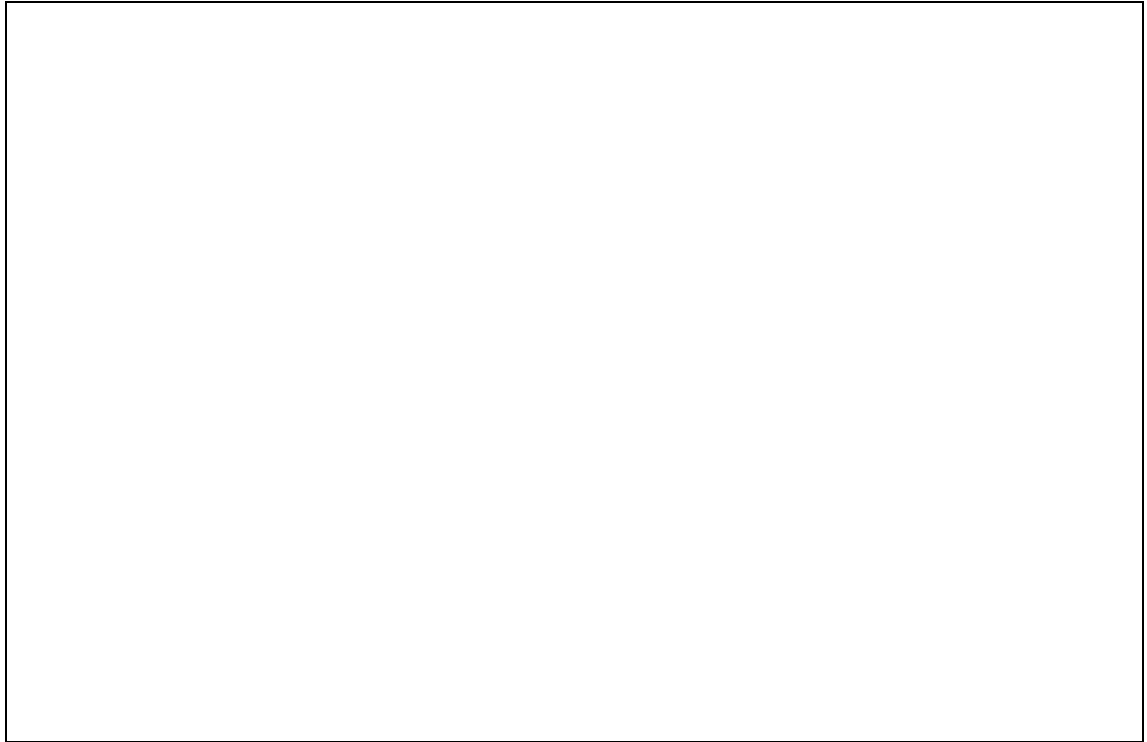

Figure 2.4: 12V or 24V DC Pulse Width Modulator circuit

2.4.1.2 Specifications

The PWM frequency is 400 Hz, current ratings is 3A with an IRF521 FET, more that 10A with an IRFZ34N FET and heat sink, PWM circuit current is 12V with no LED and no load, and lastly the operating voltage is 12V or 24V depending on the configuration.

2.4.1.3 Working Principle of The Circuit in Figure 2.4

The PWM circuit requires a steadily running oscillator to operate. U1a and U1d form a square/triangle waveform generator with a frequency of around 400 Hz. U1c is used to generate a 6 Volt reference current which is used as a virtual ground for the oscillator, this is necessary to allow the oscillator to run off of a single supply instead of a +/- voltage dual supply.

U1b is wired in a comparator configuration and is the part of the circuit that generates the variable pulse width. U1 pin 6 receives a variable voltage from the R6, VR1, R7 voltage ladder. This is compared to the triangle waveform from U1-14. When the waveform is above the pin 6 voltage, U1 produces a high output. Conversely, when the waveform is below the pin 6 voltage, U1 produces a low output. By varying the pin 6 voltage, the on/off points are moved up and down the triangle wave, producing a variable pulse width. Resistors R6 and R7 are used to set the end points of the VR1 control, the values shown allow the control to have a full on and a full off setting within the travel of the potentiometer. These part values may be varied to change the behavior of the potentiometer.

Finally, Q1 is the power switch, it receives the modulated pulse width voltage on the gate terminal and switches the load current on and off through the Source-Drain current path. When Q1 is ON, it provides a ground path for the load, when Q1 is OFF; the load's ground is floating. Care should be taken to insure that the load terminals are not grounded or a short will occur.

The load will have the supply voltage on the positive side at all times. LED1 gives a variable brightness response to the pulse width. Capacitor C3 smoothes out the switching waveform and removes some RFI, Diode D1 is a flywheel diode that shorts out the reverse voltage kick from inductive motor loads.

In the 24 V mode, regulator U2 converts the 24 V supply to 12 V for running the PWM circuit, Q1 switches the 24 V load to ground just like it does for the 12 V load. The schematic of the Figure 2.3 is for instructions on wiring the circuit for 12 V or 24 V.

When running loads of 1A or less, no heat sink is needed on Q1, if users plan to switch more current, a heat sink with thermal greas is necessary. Q1 may be replaced with a higher current device; suitable upgrades include the IRFZ34N, IRFZ44N, or IRFZ48N. All of the current handling devices switch S1, fuse F1, and the wiring between the FET, power supply, and load should be rated to handle the maximum load current.

2.4.1.4 Parts

Table 2.1: Parts of the Figure 2.4

U1	LM324N quad op-amp
U2	78L12 12 volt regulator
Q1	IRF521 N channel MOSFET
D1	1N4004 silicon diode
LED1	Red LED
C1	0.01uF ceramic disc capacitor, 25V
C2-C5	0.1uF ceramic disk capacitor, 50V
R1-R4	100K 1/4W resistor
R5	47K 1/4W resistor
R6-R7	3.3K 1/4W resistor
R8	2.7K 1/4W resistor
R9	1K 1/4W resistor
VR1	10K linear potentiometer
F1	3 Amp, 28V DC fast blow fuse
S1	toggle switch, 5 Amps