

OPTIMUM DESIGN OF RECTIFIER CIRCUIT FOR RF ENERGY HARVESTING

SADEQ MOHAMMED HUSSEIN ALI AL MUTAMAYEZ

**This Report is Submitted in Partial Fulfillment of Requirements for the Bachelor
Degree of Electronic Engineering (Telecommunication Electronics)**

**Faculty of Electronic and Computer Engineering
Universiti Teknikal Malaysia Melaka**

June 2015



UNIVERSITI TEKNIKAL MALAYSIA MELAKA
FAKULTI KEJURUTERAAN ELEKTRONIK DAN KEJURUTERAAN KOMPUTER

**BORANG PENGESAHAN STATUS LAPORAN
PROJEK SARJANA MUDA II**

Tajuk Projek : OPTIMUM DESIGN OF RECTIFIER CIRCUIT FOR RF ENERGY HARVESTING
Sesi Pengajian :

2	2	/	1	5
---	---	---	---	---

Saya ...SADEQ MOHAMMED HUSSEIN ALI AL MUTAMAYEZ

(HURUF BESAR)

mengaku membenarkan Laporan Projek Sarjana Muda ini disimpan di Perpustakaan dengan syarat-syarat kegunaan seperti berikut:

1. Laporan adalah hakmilik Universiti Teknikal Malaysia Melaka.
2. Perpustakaan dibenarkan membuat salinan untuk tujuan pengajian sahaja.
3. Perpustakaan dibenarkan membuat salinan laporan ini sebagai bahan pertukaran antara institusi pengajian tinggi.
4. Sila tandakan (\checkmark) :

SULIT*

*(Mengandungi maklumat yang berdarjah keselamatan atau kepentingan Malaysia seperti yang termaktub di dalam AKTA RAHSIA RASMI 1972)

TERHAD**

** (Mengandungi maklumat terhad yang telah ditentukan oleh organisasi/badan di mana penyelidikan dijalankan)

TIDAK TERHAD

Disahkan oleh:

(TANDATANGAN PENULIS)

(COP DAN TANDATANGAN PENYELIA)

Tarikh:

Tarikh:

DECLARATION

I hereby declare that I am the sole author of this thesis except as cited in the reference. This is a true copy of the thesis, including any required final revisions as accepted by my supervisor.

Signature : _____

Name : _____

Date : _____

APPROVAL

I hereby declare that I have read this thesis and in my opinion this thesis is sufficient in term of scope and quality for the award for the Bachelor Degree of Electronic Engineering (Telecommunication Electronic).

Signature : _____

Name : _____

Date : _____

ACKNOWLEDGEMENTS

This thesis would not have been possible without the help and support of many people to whom I would like to express my gratefulness. In the first place, I would like to thank my supervisor Professor Madya Dr Zahriladha Bin Zakaria. Your constant support and patience was always very motivating, and the many fruitful discussions inspired much of the work presented in this thesis. I have benefited a lot from your experience and I am very glad that I got the chance to be under your supervision.

My sincere thankful to: Mr Rammah Al Ahnomi and Mr. Mohd Arifin for their valuable discussions, as well as assistance during designing and fabrication process.

Finally, I would like to thank my family for their endless love and support

ABSTRACT

The objective of this research is to propose novel circuit designs that enable RF to DC conversion for RF energy harvesting applications. Compared to other commonly observed alternative energy sources, such as solar and wind, RF harvesting can provide continuous supply of energy, and is not completely impaired by bad weather conditions and indoor use. However, obtaining a usable yield from this energy source is challenging as the amplitude of the arriving signals is considerably low. The contribution of this thesis goes beyond conceptual design alone, and has fabrication on a PCB to demonstrate how such a circuit can be used to charge mobile phones, tablets, and other low power devices. Results reveal approximately 100 % improvement over other existing commercialized designs in the power range of -20 to 20 dBm. As increased demand for remote and disposable sensor, there is an increasing interest in battery-less systems use energy harvesters. Thus, an optimum design of rectifier circuit with Wilkinson power divider which has potential to be used for RF energy harvesting system was introduced. A Wilkinson power divider, single stage rectifier circuit, integration of single stage rectifier circuit with Wilkinson voltage combiner, and integration double stage rectifying circuit with Wilkinson power divider are designed, simulated, fabricated and measured in this study by using Agilent Advanced Design System (ADS) 2011. Simulation and measurement of rectifier circuit were carried out at various input power levels at frequency 2.45 GHz. At an incident signal of 16 dBm, the system managed to produce an output DC voltage of 6.66 V, 6.65 V, 6.654 V and 13.54 V for single stage rectifier circuit, integrated circuit of single stage rectifier circuit with Wilkinson power combiner, and integrated of single and double stage rectifier circuit with Wilkinson power divider respectively.

ABSTRAK

Objektif kajian ini adalah untuk mencadangkan reka bentuk litar novel yang membolehkan RF penukaran DC untuk RF aplikasi penuaian tenaga. Berbanding dengan yang lazim dilakukan sumber tenaga alternatif lain seperti solar dan angin, penuaian RF boleh menyediakan bekalan tenaga yang berterusan, manakala ia tidak boleh terjejas oleh keadaan cuaca yang buruk dan kegunaan dalaman. Walau bagaimanapun, untuk mendapatkan hasil yang boleh digunakan dari sumber tenaga ini adalah mencabar kerana amplitud isyarat yang tiba adalah rendah. Sumbangan karya ini melampaui reka bentuk konsep sahaja, dan mempunyai fabrikasi pada PCB untuk menunjukkan bagaimana seperti litar yang boleh digunakan untuk mengecas telefon mudah alih, tablet, dan peranti kuasa rendah yang lain. Keputusan mendedahkan kira-kira peningkatan 100% berbanding reka bentuk lain yang dikomersialkan sedia ada dalam lingkungan kuasa -20 ke 20dBm. Peningkatan permintaan untuk sensor jauh, terdapat minat yang semakin meningkat dalam sistem bateri yang kurang menggunakan tenaga penuai. Oleh itu, reka bentuk optimum litar penerus dengan kuasa Wilkinson pembahagi yang mempunyai potensi untuk digunakan bagi sistem penuaian tenaga RF diperkenalkan. A pembahagi kuasa Wilkinson, tunggal litar peringkat penerus, integrasi peringkat litar penerus tunggal dengan Wilkinson pembahagi voltan, dan integrasi peringkat berganda membetulkan litar dengan kuasa Wilkinson pembahagi direka bentuk, simulasi, fabrikasi dan diukur dalam kajian ini dengan menggunakan Agilent Rekabentuk Sistem Lanjutan (ADS) 2011. Simulasi dan pengukuran litar penerus telah dijalankan di pelbagai peringkat kuasa masukan pada frekuensi 2.45 GHz. Pada isyarat peristiwa 16dBm, sistem itu berjaya menghasilkan keluaran DC voltan 6.66 V, 6.65 V, 6,654 V dan 13.54 V untuk tunggal litar peringkat penerus, litar bersepadu peringkat litar penerus tunggal dengan kuasa Wilkinson penggabung, bersepadu tunggal dan peringkat berganda litar penerus dengan Wilkinson kuasa masing-masing.

CHAPTER	TITLE	PAGE
	DECLARATION	i
	SUPERVISOR DECLARATION	ii
	ABSTRACT	iii
	ABSTRAK	iv
	ACKNOWLEDGEMENTS	v
	TABLE OF CONTENTS	vi
1.	INTRODUCTION	
	1.1. Introduction	1
	1.2. Problem statement	5
	1.3. Objective of the Project	5
	1.4. Project Scope	6
	1.5. Methodology	6
2.	LITERAURE REVIEW	
	2.1. Introduction	11
	2.2. Voltage divider circuit	11
	2.3. Rectifying Circuit	18
	2.4. Voltage Multiplier	20
	2.5. Number of Stage	22
	2.6. Diode for Rectifying Circuit	23
	2.7. Loads for Rectifying Circuit	24

3. PROJECT METHODOLOGY

Introduction	25
Rectifier Circuit Design	27
Wilkinson power divider circuit design	30
Integration of single stage rectifier with power combiner	31
Integration of double stage rectifier with power divider	34
Tuning and optimization	35

4. RESULTS & DISCUSSION

4.1 Introduction	42
4.2 Simulation	42
4.2.1 Wilkinson power divider	42
4.2.2 Single stage rectifier circuit	45
4.2.3 Single stage with power combiner	46
4.2.4 Double stage rectifier with power divider.	48
4.2.5 Choice of Load for Rectifier Circuit	53
4.3 Measurement	55
4.3.1 Wilkinson power divider	55
4.3.2 Rectifier circuits	56
4.4 Comparison between simulation and measurement results	60

5. CONCLUSION & RECOMMENDATION

5.1 Conclusion	64
5.2 Recommendation	65

REFERENCES	66
-------------------	-----------

LIST OF TABLES

Table 2.1 : Summary of literature review

Table 3.2: Interdigital Capacitor Basic Structure

Table: 4.2: Output voltage values for single stage rectifier circuit with different loads

LIST OF FIGURES

Figure 1.1: Energy demand	1
Figure 1.2: Ambient RF energy harvesting	4
Figure 2.1: Concept of power divider and combiner [6].	11
Figure 2.2: Equivalent transmission line circuit for a Wilkinson power divider	12
Figure 2.3: Equivalent lumped element circuit for a Wilkinson power divider	15
Figure 2.4: Substrate parameters	16
Figure 2.5: Typical field lines for the main transverse electric field in a Microstrip line	16
Figure 2.6: Complete RF energy harvesting as a charging system	19
Figure 2.7: Double stage Villard voltage multiplier circuit, courtesy of [26]	21
Figure 2.8: Double stage Cockroft-Walton voltage multiplier circuit, courtesy of [26]	21
Figure 2.9: Double stage Dickson voltage multiplier circuit, courtesy of [26]	21
Figure 2.10: Effect of number of stages on the output voltage of energy harvesting circuit	22
Figure 2.11: Comparison of low and high forward voltage	24
Figure 3.1: Flow chart of the project	26
Figure 3.2: Lumped elements design for single stage rectifier circuit	28
Figure 3.3: Microstrip line design of single stage rectifier circuit	29
Figure 3.4: Layout design of single stage rectifier circuit at 2.45 GHz	30
Figure 3.5: Lumped element design of wilkinson power divider at 2.45GHz	30
Figure 3.6: Optimised wilkinson power divider at 2.45 GHz using open stub technique	31
Figure 3.7: Layout design of the power divider at 2.45 GHz	32
Figure 3. 8: Lumped element design of single stage rectifier with power combiner	32
Figure 3. 9: Microstrip line desin of single stage rectifier with power combiner	33
Figure 3.10: Layout desin of single stage rectifier circuit with power combiner	33

Figure:3.11: Lumped element design of double stage rectifier with power divider	34
Figure:3.12: Microstrip desin of double stage rectifier circuit with power divider	34
Figure: 3.13: Layout line desin of three stage rectifier circuit with power divider	35
Figure :3.14: Tuning process of single stage rectifier circuit	36
Figure: 3.15: Simulation result of single stage rectifier circuit before tuning	36
Figure: 3.16: Simulation result of single stage rectifier circuit after tuning	37
Figure: 3.17: Simulation result of single stage rectifier with power combiner before tuning	37
Figure: 3.18: Simulation result of single stage rectifier with power combiner after tuning	37
Figure: 3.19: Simulation result of double stage rectifier with power divider before tuning	38
Figure: 3.20: Simulation result of double stage rectifier with power divider after tuning	38
Figure: 3.21: Measurement setup of single stage rectifier circuit	40
Figure: 3.22: Integration of single stage rectifier circuit with power combiner	40
Figure 3.23: Integration of double stage rectifier circuit with Wilkinson power divider	40
Figure: 3.24: Charging process of mobile phone using rectifier circuit	41
Figure: 4.1: Microstrip design of Wilkinson power combiner at 2.45GHz	42
Figure: 4.2: Simulated results of the proposed power divider at 2.45GHz	43
Figure: 4.3: Design of single stage rectifier circuit at 2.45GHz	44
Figure: 4.4: Simulation result of single stage rectifier circuit	44
Figure: 4.5: Design of single stage rectifier with Wilkinson power combiner at 2.45GHz	45
Figure: 4.6: Simulation result of single stage rectifier with Wilkinson power combiner	46
Figure: 4.7: Double stage rectifier circuit integrated with Wilkinson power divider	47
Figure: 4.8: Simulation result of double stage rectifier with Wilkinson power divider	47
Figure: 4.9: Simulation of DC voltage versus input power for different loads in single stage	49
Figure: 4.10: Manufactured standard Wilkinson's power combiner.	50

Figure: 4.11: Measured value of S11, S12, S13, of the proposed power divider at 2.45 GHz	50
Figure: 4.12: Single stage rectifier circuit prototype	51
Figure: 4.13: Prototype of single stage rectifier circuit with Wilkinson power combiner	52
Figure: 4.14: Prototype of double stage rectifier with Wilkinson power divider	52
Figure: 4.15: Measurement setup of the single stage rectifier circuit	52
Figure: 4.16: Measurement setup of the single stage rectifier circuit with power combiner	53
Figure: 4.17: Measurement setup of the double stage rectifier integrated with power divider	53
Figure: 4.18: Measurement result of S11, S12, S13 for power divider circuit at 2.45 GHz	55
Figure: 4.19: Measurement result of single stage rectifier circuit	56
Figure: 4.20: Measurement result of integrated of rectifier circuit with power combiner	57
Figure: 4.21: Measurement result of single stage rectifier circuit with power divider	58
Figure: 4.22: Measurement result of double stage rectifier circuit with power divider	58

CHAPTER 1

1.1 Introduction

Energy is a basic necessity for sustaining human life, which pervades each and every one of our activities. In the very early days, we used muscle power (both human and animals) to drive simple implements and machines, which could only run for a limited time and had limitations on their continuous availability. The biggest transition happened when we learnt to generate energy, by transforming one state of energy, possibly latent, to another. Suddenly, vast possibilities opened up where energy could be obtained, stored, and transferred across large distances

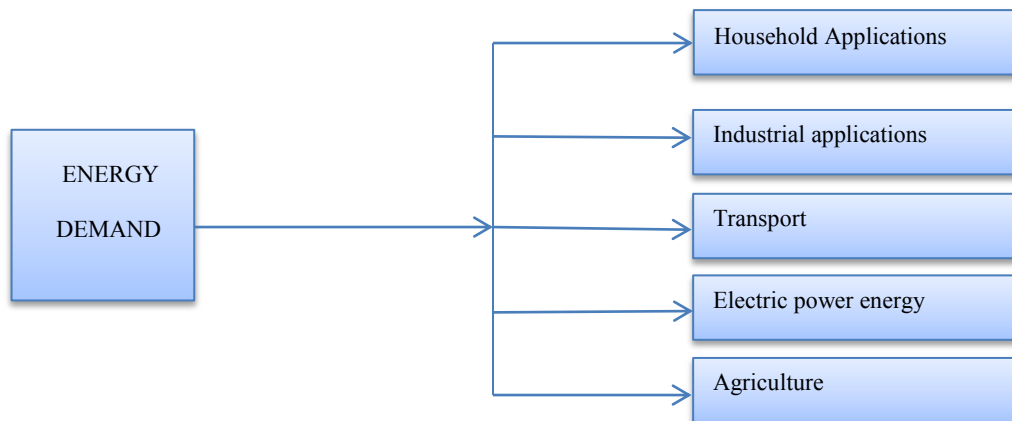

Figure 1.1 Energy demand

Renewable energy sources provide an alternative to conventional natural sources, of which there are limited supplies. Renewable energy can be broadly defined as a kind of energy that is generated from natural sources, which is not typically depleted, such as sunlight, wind, rain, tidal motion, flowing water, biomass, geothermal heat, among others.

A complete overview of the how energy from different sources is generated, stored and consumed is given in Figure 1.2. The technique of converting this raw energy source into useful electrical energy is called as energy harvesting. Quoting the Energy Harvesting Forum, energy harvesting is the process of capturing minute amounts of energy from one or more of these naturally-occurring (renewable) energy sources, accumulating them and storing them for later use [2].



Figure 1.2 Energy harvesting systems, courtesy of [1]

1.1.2 Radio Frequency Based Energy Harvesting

This technique of energy harvesting relies on the energy contained in the RF fields generated by electromagnetic wave transmitters, such as TV towers, wireless radio networks and cell phone towers. Conceptually, this energy is captured and converted into functional DC voltage by using a specialized circuit directly connected to a receiving antenna. Although this technique has least energy intensity compared to other energy harvesting systems, RF energy harvesting systems have many useful features, not present otherwise.

Such systems can be used in any location that has a high incidence of strong ambient RF waves or in specific applications where there is a presence of a dedicated transmitter. Hence RF energy harvester is generally not dependent on time of the day, geographical aspects of the region, weather conditions etc., which must be considered in other examples of energy harvesting systems including solar, and wind energy. RF energy can also be used to drive more than one device at the same time. For instance, the energy spread from any omnidirectional transmitter (TV tower, GSM base station etc.) can be scavenged by more than one RF energy harvester.

1.1.3 Components of RF Energy Harvesting System

Figure 1.3 shows the components of energy harvesting circuit. The incident RF power is converted into DC power by the voltage multiplier. The matching network, composed of inductive and capacitive elements, ensures the maximum power delivery from antenna to voltage multiplier. The energy storage ensures smooth power delivery to the load and as a reserve for durations when external energy is unavailable. Such a design needs to be carefully crafted. RF harvesting circuits involve a complex interplay of design choices, which must be considered together. This problem is addressed by considering a multi-stage design of the voltage multiplier, whose operating points are decided by solving an optimization framework.

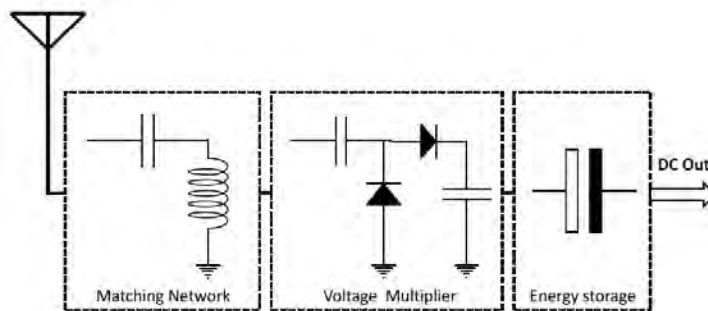

Figure 1.3 Ambient RF energy harvesting

1.1.4 Application Areas of RF Energy Harvesting

With the growing popularity and applications of large-scale, sensor-based wireless networks (e.g, structural health monitoring, human health monitoring, to name a couple), the need to adopt inexpensive, green communications strategies is of paramount importance. One approach is to deploy a network comprising self-powered nodes, i.e., nodes that can harvest ambient energy from a variety of natural and man-made sources for sustained network operation [2]. This can potentially lead to significant reduction in the costs associated with replacing batteries periodically. Moreover, finite electrical battery life is encouraging the companies and researchers to come up with new ideas and technologies to drive wireless mobile devices for an infinite or enhanced period of time. Batteries add to size and their deposition cause environmental pollution. Thus, there is a growing demand for this technology because this energy harvesting technology presents a promotable future in low power consumer electronics and wireless sensor networks.

1.2 Problem Statement

Battery replacement may be both practically and economically infeasible, or may involve significant risks to human life. Thus, there is a strong motivation to enable an off-the-shelf wireless sensor network (WSN) with energy harvesting capability that would allow a sensor to replenish part or all of its operational costs, thereby taking the first steps towards realizing the vision of a perennially operating network.

A power source combined with energy harvesting can provide wireless devices for low maintenance cost and extended battery life, in place of conventional batteries with fixed energy storage, for point-to-point wireless communications. In addition to the challenge of transmitting the communication signal, a good rectifier which convert RF to DC signal, is needed so as to maximize the throughput. It should have high efficiency to convert as much of that energy as possible to usable power. Thus by introducing an integration circuit design of rectifier power divider and combiner was introduced in order to achieve maximum efficiency which in turn will have a great impact in the development study of RF energy harvesting system.

1.3 Objectives

The objective of this project is to develop high efficiency and low power consumption of RF-DC conversion rectifier circuit. In addition, the sub-objectives are stated as follow:

- Study the effect of Wilkinson power combiner for single stage rectifying circuit
- Study the effect of Wilkinson power divider for rectifying circuit
- To fabricate and validate the designs in laboratory

1.4 Scope of Project

The main objective of this project is to design an optimum rectifier circuit that can be used to convert the small RF signal into a constant DC voltage to charge or operate low power devices such as mobile phones, tablets, and tracking system. The first step in designing process is doing a literature review on the types of rectifier circuits that have been proposed by previous researchers.

Then it followed by choosing the type of diode for the rectifier circuit, from literature review it was observed that HSMS286B diode was the suitable candidate for the rectifier circuit since it has a high sensitivity switching voltage. After that, an integrated circuit of rectifier with power divider and combiner will to be designed in order to improve the performance of rectifier circuit. Finally the proposed designs will be fabricated and measured. Comparison will be done between simulation and measurement results. Advance design system (ADS) will be used to design the single stage rectifier circuit, power divider circuit, single stage rectifier circuit with power combiner, and integration of power divider with single and double stage rectifier circuit.

1.5 Methodology

1.5.1 Project Planning

Amongst the most imperative part in the project development is the project planning. A Gantt diagram is arranged to help in actualizing the process. The calendar is done to guarantee all the process in this project is all arranged and sorted out. The timetable in the Gantt diagram must be followed with a specific end goal to verify the project can be done within of the recommended time.

1.5.2 Data Collection

Implementation of the project started by doing a comprehensive study about the RF-DC conversion development. After that the specification of the rectifier circuit and power divider at a specific designed resonant frequency of 2.45 GHz was achieved. It was then followed by designing and developing the circuit by using ADS version 2011 software for a single stage

rectifier circuit, integrated circuit of single stage rectifier with power combiner, and integrated circuit of rectifier with power divider. Finally fabrication and measurement process was done for the proposed design in order to test and justify how such circuits can be used to charge low power devices such as mobile phone, tablets, tracking system.

CHAPTER 2

LITERATURE REVIEW

2.1 Introduction

In a few years before, with the incensement of electronic company devices produce micro-power electronic applications, people start to explore on the energy harvesting technologies as it can promise for the low power source. Thus, RF energy harvesting from the ambient will have an important role in the future microelectronic circuits [3]. This technology will become as a big role for the alternative low power technology as it can reduce for the long life operation cycles, reduce cost of maintenance, keep clean of environment and researcher try to prove it can operate reliably as a good system for the environmental and industrial monitoring

Harvestable sources of energy include mechanical energy resulting from vibration, stress and strain, thermal energy from furnaces, combustion engines and other heating sources, even biological, solar energy from all forms of light sources, ranging from lighting, light emissions and the sun, electromagnetic energy that are captured via inductors, coils and transformers; wind and fluid energy resulting from air and liquid flow, chemical energy from naturally recurring or biological processes and RF energy from ubiquitous radio transmitters and television broadcasting [4].

The usefulness of RF in the frequency band between kHz up to some GHz can be found and converted into electrical energy [5]. Hence, the AC output voltage need to rectify and convert into the usable DC voltage to supply to the load circuit which contents with electronic devices. Literature studies have been conducted on journals to collect relevant information and facts that can be used in the design process of this project. Table 2.1 below shows a summary of the literature reviews for this project.

Table 2.1 Summery of literature review

Year	Reference	Method	Remark
2009	[14]	The application of simultaneous conjugate matching to wireless power transfer links to realize maximum theoretical gain; adaptive matching circuitry to compensate for link variations; and a high efficiency rectifier was demonstrated	A tunable matching network for improving the efficiency of the power link with switched-capacitor banks involving a continuous correction algorithm was demonstrated. However, the quantitative analysis on the matching network is not provided in detail operation
2012	[16]	A diode model and the characteristic of diode HSMS-2860 which is available for low power levels. The rectifier circuits were simulated by circuit simulation and co-simulation. Then, the matching circuit was designed for optimum power rectification at a given incident power was presented.	3 different rectifiers to improve conversion efficiency were proposed. However, the parametric analysis on each rectifier design and its properties are not described in detail.
2009	[20]	The impedance transformation with high quality factor (Q) in front of a Schottky-Diode using a quartz resonator at 24 MHz was presented.	The sensitivity of the rectifier circuit using a quartz resonator was improved. However, the spurious modes in quartz resonator are not taken into account where the transmission characteristics might cause measurement error.
2012	[7]	Design of dual band rectifier by using zero bias Schottky diode HSMS-285C The voltage output is twice the input peak voltage	The DC output power (P_o) can be calculated by the multiplication of DC output voltage (V_o) and DC load current (I_o) $P_o = V_o \times I_o$ The performance of the circuit can be determine by the efficiency of the RF-to-DC power conversion that is the relative between the incident RF signal (P_{in}) at the input port

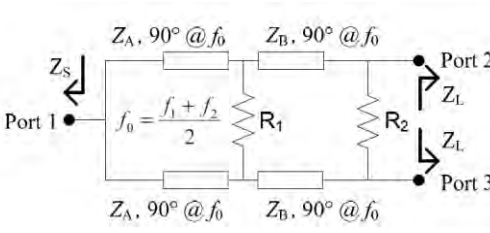
2006	[19]	<p>a dual-band power divider, designed to operate at 1 and 2.5GHz, was prototyped on a substrate with a dielectric constant of 3.38. R1 and R2 were both rounded off to the closest available resistor values of 150Ω. To improve accuracy, the layout was finely adjusted by using an electromagnetic simulator in conjunction with the high frequency models of surface-mount resistors.</p>	<p>The major difference in this design is to loosen up the return loss and port isolation in order to cover only the two pass-bands (f_1 and f_2 simultaneously) rather than at all the in-band frequencies. The advantage is an achieved wider frequency ratio (f_2 / f_1 to almost 3) than the broadband design (with upper and lower frequency ratio of less than 2), and the widest bandwidth to any existing dual-band designs</p> 
2012	[15]	<p>A design, optimization and characterization of a high-efficiency ISM band dual patch rectenna well suitable for driving smart actuators and wireless sensors or sensor nodes. Then, the circuit has been optimized to operate at 10mW RF input power which corresponds to a power density of about 100 W/cm² on the dual patch antenna and an efficiency of 87% but some results will be also given at low power (around 1 mW).</p>	<p>A dual patch rectenna capable of achieving more than 80% RF-to-DC conversion efficiency at low/medium power densities. The circuit is based on a full-wave rectifier, designed and optimized at 2.45 GHz with ADS software and the FDTD algorithm. The performances of the rectenna have been accurately predicted using the full-wave 3D-FDTD method extended to lumped linear and non-linear elements.</p>