

**EXPERIMENTAL STUDY OF SINGLE AXIS MAGNETIC ATTRACTION
FORCE**

**SHAKIRAH BINTI YUSOF
B011010291**

**Bachelor of Electrical Engineering
(Power Electronics And Drives)
June 2014**

“I hereby declare that I have read through this report entitle “Experimental Study Of Single Axis Magnetic Attraction Force” and found that it has comply the partial fulfillment for awarding the degree of Bachelor of Electrical Engineering (Power Electronics and Drives)

Signature :

Supervisor’s Name : DR. KASRUL BIN ABDUL KARIM

Date : 18 JUNE 2014

EXPERIMENTAL STUDY OF SINGLE AXIS MAGNETIC ATTRACTION FORCE

SHAKIRAH BINTI YUSOF

A report submitted in fulfilment of the requirement for the degree

Faculty of Electrical Engineering

UNIVERSITI TEKNIKAL MALAYSIA MELAKA

2014

I declare that this report entitle “Experimental Study Of Single Axis Magnetic Attraction Force” is the result of my own research except as cited in the references. The report has not been accepted for any degree and is not concurrently submitted in candidature of any other degree.

Signature :

Name : SHAKIRAH BINTI YUSOF

Date :

ABSTRACT

Magnetic levitation is the levitating process of an object by using magnetic field as the source of energy. Magnetic levitation also known as Maglev is one of the advanced technology that become phenomena that fascinated people to study about it especially in transportation industry. It is works based on magnetic attraction or repulsion in order to maintain the gap between two positions. The aim of this project is want to develop experimental set up of single axis magnetic attraction force. Besides that, the other purpose of this project is to experiment the behaviour of attraction force for the developed experimental setup. This project only covers the fundamental of single axis magnetic attraction force that can be implementing in high speed transportation and magnetic suspension. Besides that, this project wants to test the behaviour of the attraction force between two parameters which are current and distance. This project also tests the attraction force that occurs between the winding and the metal ball. From this project we can conclude that when the amount of current is directly proportional to the distance. When the distance was increased, the amount of current to attract the metal ball also increased

ABSTRAK

Daya apungan magnetik adalah satu proses mengapungkan objek dengan menggunakan medan magnet sebagai sumber tenaga. Apungan magnet yang turut dikenali sebagai maglev merupakan teknologi terkini yang menarik ramai pengkaji untuk mengkaji akan hal ini terutamanya dalam bidang pengangkutan. Maglev dapat berfungsi dalam dua keadaan sama ada menggunakan daya tolakan atau daya tarikan untuk mengekalkan jarak antara dua kedudukan. Matlamat projek ini dijalankan adalah untuk mewujudkan satu eksperimen untuk mengendalikan tarikan magnetik pada paksi tunggal. Selain daripada itu, tujuan lain adalah untuk mengenalpasti sifat-sifat tarikan magnetik pada paksi tunggal terhadap eksperimen yang dijalankan. Malah eksperimen ini turut dijalankan untuk mengenalpasti kaitan antara dua parameter iaitu bilangan arus yang mengalir dan jarak bola besi. Hipotesis awal untuk eksperimen ini adalah bilangan arus yang mengalir adalah berkadar terus dengan jarak bola besi. Apabila jarak bola besi dari lilitan adalah tinggi, bilangan arus yang mengalir untuk menarik bola turut meningkat.

ACKNOWLEDMENT

Appreciation and special thanks to the author's supervisor, Dr. Kasrul bin Abdul Karim for a chance to accomplish this thesis with title 'Single Axis Electromagnetic Attraction Force'. The cooperation, supervision and support that he gave are truly helping her to finishing this thesis. He also always allows the author to ask him any question and prompt replies for her uncertainties during completing the thesis.

Grateful thanks to the author's family because of encouragement support and always become her strength to finish her thesis. Advices and ideas from family are really helpful in order to keep going the thesis and this project.

Special thanks to all author friends that involve directly or indirectly in order to complete this thesis. Besides that, friends make she realize the value of friendship and working together as a team in order to achieve a set of goals such as the successful of the thesis. Their contribution during completing this project really author appreciates.

Great appreciation goes to the author faculty, Faculty of Electrical Engineering, Universiti Teknikal Malaysia Melaka, (UTeM) which placed her for study, gain valuable knowledge and set of skills for four years.

Finally, the author apologizes to all other unnamed person who helped her in various ways. She really appreciated for every single contribution that all of you have gave to her. Without support from them it really hard for her to finish her thesis.

TABLE OF CONTENT

CHAPTER	TITLE	PAGE
	ABSTRACT	
	ABSTRAK	
	ACKNOWLEDGEMENT	
	LIST OF TABLE	i
	LIST OF FIGURES	ii
	LIST OF ABBREVIATION	iii
CHAPTER 1	INTRODUCTION	
	1.1 PROJECT BACKGROUND	1
	1.2 PROBLEM STATEMENT	1
	1.3 OBJECTIVES	2
	1.4 SCOPE	2
	1.5 PROJECT OUTLINES	2
CHAPTER 2	LITERATURE REVIEW	
	2.2 ABOUT MAGNETIC FIELD	4
	2.1 MAGNETIC LEVITATION	5

	2.3 ADVANTAGES OF MAGNETIC LEVITATION	6
	2.4 RELATED PREVIOUS WORK	6
	2.4 SUMMARY OF REVIEW	12
CHAPTER 3	METHODOLOGY	
	3.1 RESEARCH METHODOLOGY	13
	3.1.1 FLOW CHART	13
	3.2 EXPERIMENTAL SETUP	14
	3.3 CALCULATION OF ATTRACTION FORCE	16
	3.4 EXAMPLE OF CALCULATION	17
	3.5 TESTING AND MEASUREMENT	19
	3.5.1 TESTING HARDWARE	19
CHAPTER 4	RESULT AND DISCUSSION	
	4.1 RESULTS & DISCUSSIONS	22
	4.1.1 EXPERIMENTAL SETUP	22
CHAPTER 5	CONCLUSION AND RECOMMENDATION	
	5.1 CONCLUSION	25
	5.2 RECOMMENDATION	25
	REFERENCES	
	APPENDICES	

LIST OF TABLE

Table 3.1:	Parameters for Calculation
Table 4.1:	Measurement Result for Reading I and II
Table 4.2:	Average Result

LIST OF FIGURE

Figure 2.1:	Basic Schematic System of MagLev
Figure 2.2:	Direction of Force by Using Right hand Rule
Figure 2.3:	Magnetic Levitation Sample 1 Result
Figure 2.4:	Magnetic Levitation Sample 2 Result
Figure 2.5:	Magnetic levitation Device Prototype
Figure 2.6:	Magnetic Levitation System Schematic Diagram
Figure 2.7:	Magnetic Levitation Test-Bed
Figure 2.8:	Stable Levitation of Steel Ball
Figure 2.9:	Low Cost Magnetic Levitation Kits
Figure 3.1:	Flow Chart of Project Procedures
Figure 3.2:	Experimental Setup
Figure 3.3 :	Magnetic Attarction Stand
Figure 3.4:	Copper Winding
Figure 3.5:	The Schematic Diagram
Figure 3.6:	Electromagnetic Coil Attract a Metal Ball
Figure 4.1:	Current Vs Distance Graph

LIST OF ABBREVIATION

DC	Direct Current
Emf	Electromotive force
Maglev	Magnetic Levitation

CHAPTER 1

INTRODUCTION

1.1 PROJECT BACKGROUND

Magnetic levitation is the levitating process of an object by using magnetic field as the source of energy. Magnetic levitation also known as Maglev is one of the advanced technology that become phenomena that fascinated people to study about it especially in transportation industry. It is works based on magnetic attraction or repulsion in order to maintain the gap between two positions. The aim of this project is want to develop experimental set up of single axis magnetic attraction force. Besides that, the other purpose of this project is to experiment the behaviour of attraction force for the developed experimental setup.

This project focuses on how attraction force works and to test the behaviour and the parameter involved in magnetic attraction force. The system consists of an electromagnet formed by winding the screw with and electrically conducting wire. The screw creates a magnetic field when an electrical current is passed through the wire. The formed magnetic field creates an upward attraction force on metal ball which is placed below the magnetic screw. The metal ball was placed under the winding and was tested for certain range of distance. The distance of the metal ball depends on the amount of current flow and the amount of current flow is based on the winding. If the winding is higher, the amount of current that can pass through it also increase and the distance of the metal ball can be attracted also increase. This is because, when the distance is increase, the current need to attract the ball also increases.

1.2 PROBLEM STATEMENT

Magnetic levitation is an attractive solution for high speed transportation and magnetic suspension. Magnetic levitation work based on magnetic attraction and repulsion which maintaining the gap. However maglev system is still new and unmatured especially in

Malaysia. Hence this project helps to develop the experimental setup for the magnetic attraction force. This set up will test the behaviour of the magnetic attraction force and analyse the relationship of the distance and the current.

1.3 OBJECTIVES

The objectives of this project are:

- To develop experimental set up of style axis magnetic attraction force.
- To experiment the behaviour of attraction force for the developed experimental setup.

1.4 SCOPE

This project only covers:

- The fundamental of single axis magnetic attraction force that can be implementing in high speed transportation and magnetic suspension.
- This project only to test the behaviour of the attraction force between two parameters which are current and distance. This project also tests the attraction force that occurs between the winding and the metal ball.

1.5 PROJECT OUTLINES

This project consists of five chapters. For Chapter 1, it review details about the background of this project, the problem that cause this project to be analyse, the objective and the scope of the project. In Chapter 2, it covers about the basic principles that relate with magnetic force and it applications.

In Chapter 3 is about the method and step that used to conduct this project. It covers about project methodology, analytical approach, and hardware implementation. The method was presented in flow chart because it more systematic and appropriate to understand the movement of project. The next chapter, the data are tabulate and present it in suitable form for more understanding. Then make discussion for every tabulated result. The last chapter is Chapter 5. This chapter focus on the conclusion and recommendation for future work or study based on this project. This chapter will define either our project achieve the result same as our hypothesis or not.

CHAPTER 2

LITERATURE REVIEW

2.1 ABOUT MAGNETIC FIELD

Magnets play an important role in a modern life. A huge number of devices are focus in the electromagnetic industry. Magnetic phenomena are not really modern technology because in ancient times, human beings already experienced in magnetic phenomena. This can be shown when world has produced many physics such as Oersted and Faraday that contribute in this field. Magnetic field is like gravitational fields, cannot be seen or touched. Human only can know the existence of magnetic fields by their effect object such as magnetized pieces of metal, naturally magnetic rocks like lodestone, or temporary magnets such as copper coils that carry an electrical current. Electric currents make magnetic fields, so we can define what is meant by magnetic field in terms of the electric current that generates it. It can attract ferromagnetic objects and convert electrical energy to mechanical energy. This physical force exerted by a magnet can be described as lines of flux originating at the north pole and terminating at the south pole of the magnet [1]. An electric current flowing through a loop of wire generates magnetic field and its strength depends on the current and the area of the wire loop. The magnetic field strength or also known as magnetic flux density is directly proportional to the linear current density. The concept of flux density is used to describe the intensity of the magnetic field at particular point in space. Magnetic field density is a measure of the amount of magnetic flux in a unit area perpendicular to the direction of magnetic flow. On the other hand, it also measures the amount of magnetism induced in a substance placed in the magnetic field. Below is the relationship between magnetic field strength, (H) and magnetic flux density, (B). [1]

$$B = H \times \mu$$

2.2 MAGNETIC LEVITATION

The name of Maglev extract from the word magnetic levitation. Magnetic levitation is an extremely advanced technology that various uses. This advanced technology increase energy efficiency, reduce maintenance cost, and it can be implement in various industries.

Magnetic levitation is the process of levitating metal object by overcomes the gravitational force of an object by applying opposite or counteracting magnetic force. There are divided into two types which are magnetic suspension and magnetic levitation. Magnetic suspension is a process of force attraction while magnetic levitation uses repulsion force.

Based on Earnshaw's theorem, he has said that system that using permanent magnet or electromagnets without control the current, the system is inherently unstable. Therefore, in order to achieve the stable levitation, it is necessary to control the current in an electromagnet by using position feedback of the object to levitate. Force of attraction and the distance of air gap will affect from the modification of the current.[2]

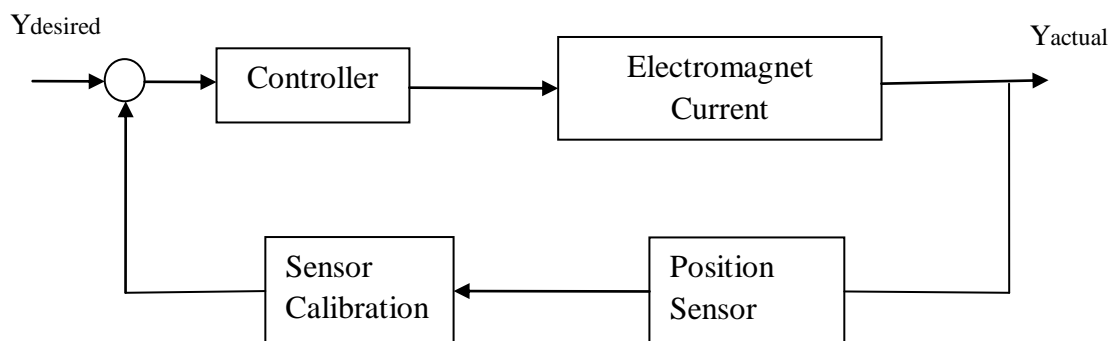

Figure 2.1: Basic Schematic System of MagLev

Y in the Figure 2.1 refers to the position. Basic schematic above shows that the position sensor as a feedback that will adjust the current to keep the object precisely centred at the desired position. When sensor detects the position of the ball it will send the information to the controller. The controller will adjust the amount of current flow through the electromagnet.

The direction of the forces created by Faraday's Law was discovered by a man named Heinrich Lenz. His theory states that "The emf induced in an electric circuit

always acts in such a direction that the current it drives around the circuit opposes the change in the magnetic flux which produces the emf.” In other words, this is stating that if there was a current that was created in a coil of wires, then the magnetic field that is being produced will be perpendicular the current direction.[3]

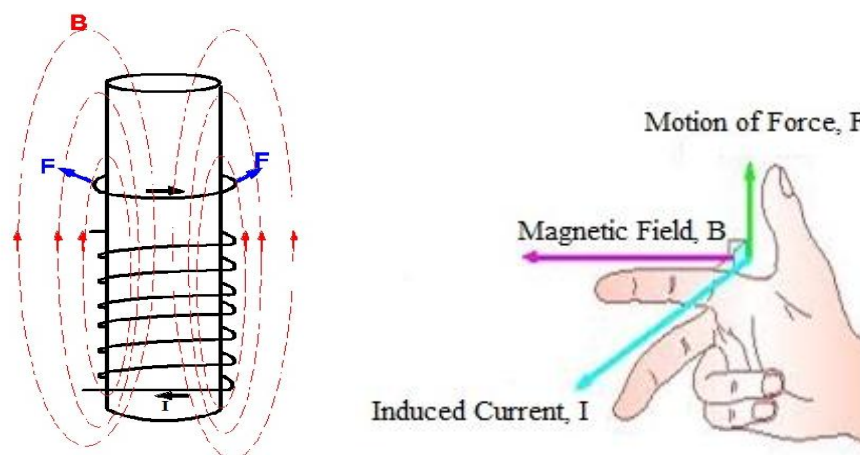

Figure 2.2: Direction of Force by Using Right hand Rule

2.3 ADVANTAGES OF MAGNETIC LEVITATION

Every single thing in the world must have their special characteristics that can make it different from others. Same as Maglev but in applications, there are more focusing maglev technology in transportation especially high speed train. Hence, the advantages and disadvantages also more focuses in that application. In motor design, the common advantage of Maglev system is they are frictionless. Because of frictionless, the motor will move smoothly in high speed. Besides that, with maglev system, the movement of motor will be more efficient and high technology implementation. It also saves energy because the movement is without friction and environmental friendly too.

2.4 RELATED PREVIOUS WORK

For previous work, there are about five sources include thesis articles, journals and conference paper that relate in this topic, Magnetic Levitation Force. First source is thesis from with project title “Magnetic Levitation on a Steel Ball”. Based on this thesis, it involves the design and implementation of a Maglev device appropriate to be

included as hardware implementation in Control System. In this thesis, the student is using an infrared emitter and detector is mounted as light transmitter and light receiver to create an invisible beam for the control circuit. Once the magnetic attract the metal ball, the ball rises towards the coil and blocks the beam. To control the circuit, feedback from infrared detector is used to adjust the current to keep the object precisely centred in the infrared beam. From this thesis, it shows that the researcher is using lead compensator control circuit for equilibrium between the magnetic attraction force and the gravity force. When both forces are in balanced condition, the ball will remain suspended without support. In this project, he used photodiode sensor based on certain criteria such as stability, sensitivity, linearity and cost. Photodiode sensor is selected because it has a peak sensitivity which is at 950nm with visible light being in the range of 400- 700 nm. This selection minimized the affects of ambient light on the magnetic levitation device.[4]

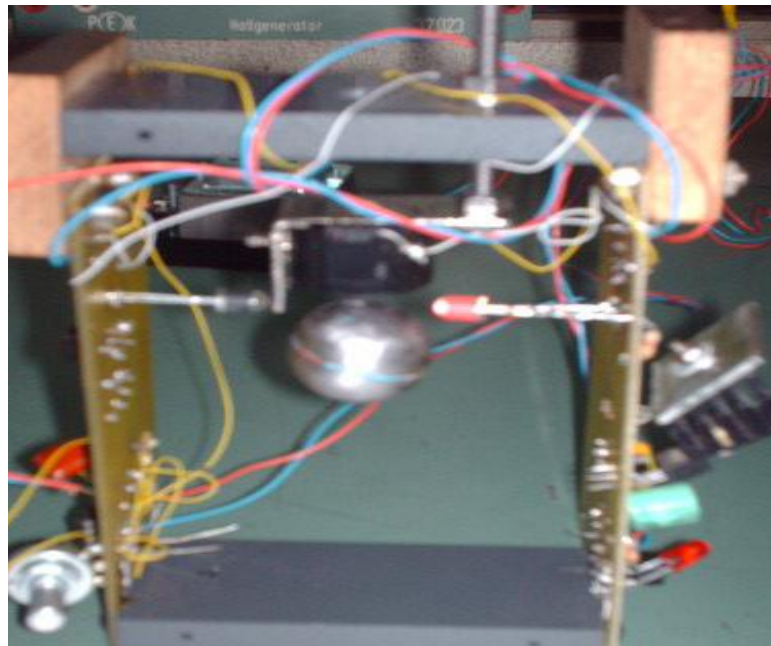

Figure 2.3: Magnetic Levitation Sample 1 Result

For sample 1, the coil can hold the steel ball with 5 gram mass about 3mm below the coil and the equilibrium current becomes 0.5A.



Figure 2.4: Magnetic Levitation Sample 2 Result

This coil can hold the steel ball with 14g mass for about 9mm below the coil and the equilibrium current is 1.5A.

Second title is about “Magnetic Levitation Testbed for Controls Student” source from paper conference. This paper focussed on how to demonstrate the levitation force by using electromagnetic coil to create the magnetic field, a ferrous object to levitate, a position sensor for height detection and a controller for feedback adjustment of the current. In this project, they are using infrared (IR) emitter-photo detector pair. The sensor work same like variable resistance and the output from this sensor is directly proportional to the amount of IR light receive. As the amount of detected light increases, the output photodetector also increase and vice versa. For design of this project, they are use PVC pipe and other PVC fittings, forming inverted U and mounted on wooden base while the electromagnet is mounted on the top centre and the position sensors on the legs of structure. The physical structure of the prototype is small (<30cm high) and portable. The structure consist of a stand which is mounted both the electromagnet and the sensor. The stand made from standard aluminium stock, a square base plate and the three machined aluminium rectangles. The structure for the maglev

device in Figure 2.3.2 is made from PVC pipe and various PVC fittings, forming an inverted U, mounted on a wooden base. [5]

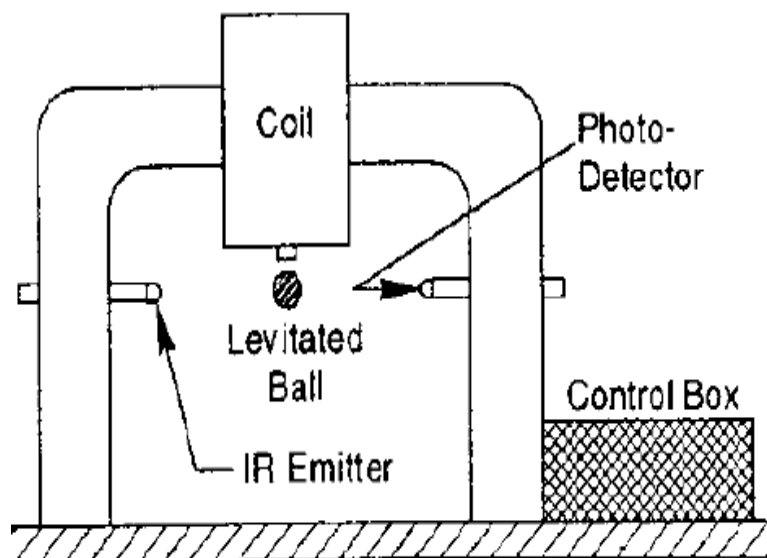

Figure 2.5: Magnetic levitation Device Prototype

Third is an article from Electrical Eng. & Technology and the title is about “A New Model of magnetic Force in Magnetic Levitation Systems”. From this paper, they are proposing a new model of magnetic control force exerted on the levitation object in magnetic levitation systems. That new model is represented numerically using 2D lookup table and that model has a feature that can show the global characteristics of the magnetic force satisfactorily compared to conventional model. The proposed model, assumes that the magnetic force is a function of the voltage applied to an electromagnet and the position of suspended object. Based on the experimental prototype, it shows that they are using cylindrical aluminium block with a strong magnet embedded on it. Besides that, they also used IR emitter and phototransistor to determine the position of levitate object. They used five phototransistors in order to make a wide range of sensing. [6]

Next sources are from research paper from University of Engineering & Technology, Taxila Pakistan. The purposes for this paper are to develop of non linear dynamic model for Maglev System and proposed linear and non linear state space controller. The basic design and concept for this Maglev project are mostly same like others project. The coil act as electromagnetic actuator and optoelectronic sensor is used to determine the position of the ferromagnetic ball. To levitate the ball in equilibrium

state, the current is regulating through the controller and electromagnetic force can be adjusted to be suitable for the weight of the steel ball. [7]

The title about “Design, Fabrication, and Control of a Single Actuator Magnetic Levitation System” study about the levitation process occurs when photocell with an incandescent light bulb is used as a medium to sense the metal ball. The displacement of the ball is measured by sensor configuration through exposing of the photocell to the light. A tube is used to ensure the ambient light does not affect the sensor measurement and it completely closed to external light except for a vertical slit located along the tube. The controller used in this thesis is lead-lag controller because that controller is made levitation of a steel ball more stable. [8]

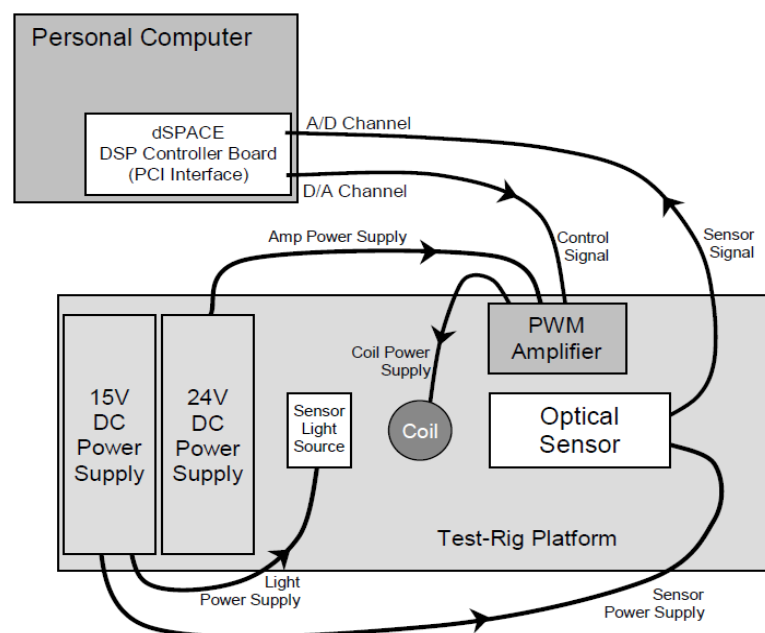

Figure 2.6: Magnetic Levitation System Schematic Diagram

From the figure above, this project consist of the basic system setup with physical sub-system interfaces. The system consists of a platform test bed and a PC with a DSP controller board. It contains electromagnet actuator, optical sensor, electromagnet PWM amplifier, and 24V and 15V DC power supply.

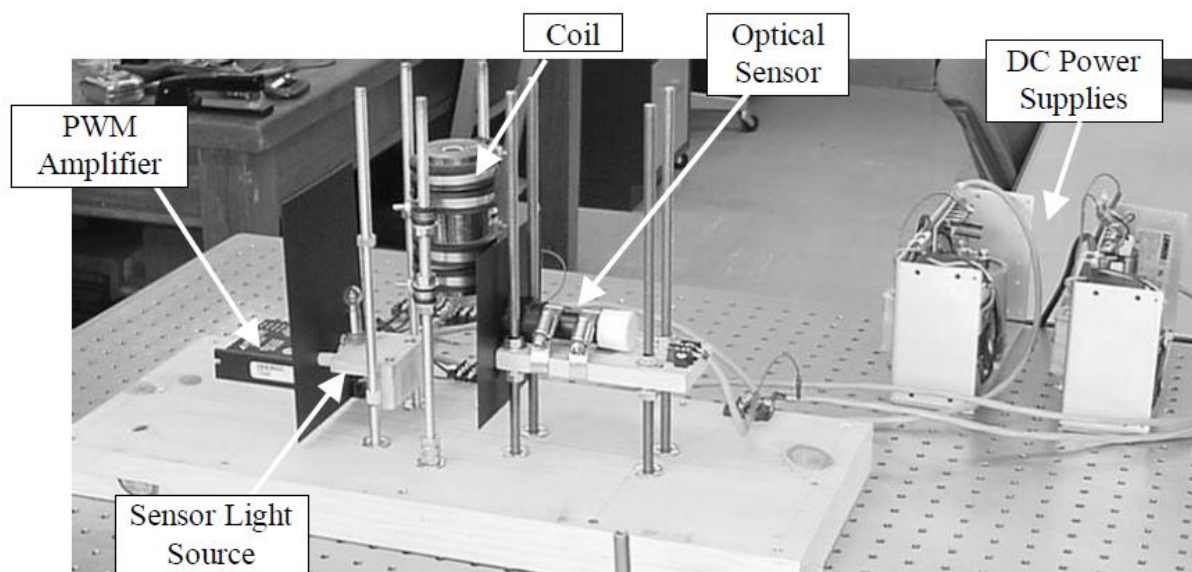

Figure 2.7: Magnetic Levitation Test-Bed

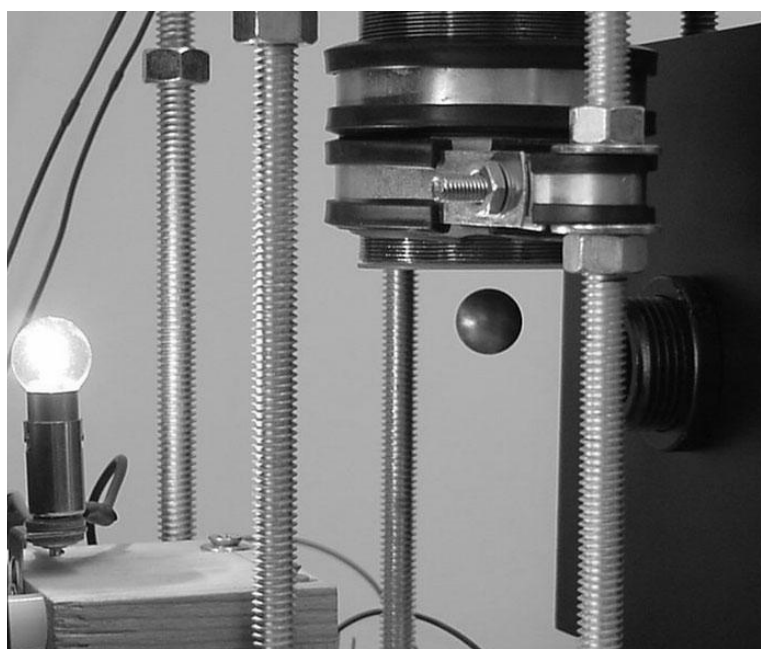

Figure 2.8: Stable Levitation of Steel Ball

The steel ball levitates when the actuator creates a magnetic field when an electrical current is passed through the wire. Upward attraction force of magnetic field will produced and passes the information to the controller. The controller will adjust the current flow to electromagnet actuator based on the position of the steel ball to create stable levitation. The controller used is lead-lag controller because it is useful to know the steady state position error when the ball levitates. [9]

The last source is from Department of Electrical Engineering and Computer Science Massachusetts Institute of Technology. Based on this project, they are developed a low cost magnetic levitation project kits for teaching system in an introductory undergraduate control system course. In this system, the position of the levitated object was detected by using Hall Effect sensor. The output voltage of the sensor drives the input of a low cost fan management which produce a pulse width modulation, PWM signal to a motor drive. Then, the signal adjusts the average current in the solenoid which control the magnetic field. Figure below shows the sample of low cost magnetic levitation force. [10]



Figure 2.9: Low Cost Magnetic Levitation Kits

2.5 SUMMARY OF REVIEW

From the previous work, it shows that almost project are same in procedure and the difference between the projects are the type of sensor used, design controller and the design of model. The controller are used to stabilize the levitate object while the sensor is used to detect the position of object and send the information to the controller. Then the controller will control the current to form a stable magnetic levitation system.

Based on their project, the idea also can be implementing in this project such as the levitate object and stand design. For this experimental project stand design, these projects also use steel (screw pole) because it is suitable and can easily adjust the height of the stand. The metal ball is used in this project and it will be attracted to the winding when current pass through it. The attraction will be made for certain distance only based on the amount of current that can pass through the winding. Higher current can pass through it; higher distance the metal ball can be attracted.