

**THE DEVELOPMENT OF PEAK CURRENT MODE CONTROL OF
BUCK CONVERTER**

Farah Atika Binti Ahmad Azam

Bachelor Of Electrical Engineering (Power Electronic & Drive)

May 2014

ABSTRACT

One of the reasons why DC-DC converter is widely used in industry nowadays is due to important of stable voltage or regulated voltage because the purpose of DC-DC converter is to stabilize the voltage. The step-down converter or buck converter will produce the output voltage less than the input voltage. As generally, the control topology that commonly used is voltage-mode control and current-mode control. In this project, the control method used is current-mode control of buck converter because this control mode is more accurate than voltage-mode control. The current-mode control is more accurate because it has better response. Current-mode control has better response because in current-mode control the sensor has sense change in load current directly so voltage error amplifier does no need to react and make a correction before producing the control voltage. The main objective and scope of the project is to design peak current-mode control of buck converter. This project also will study on this buck converter peak current-mode control and then it will be simulated using Pspice software. The project is conducted under several phases. Phase 1 is the introduction and understanding about current-mode control with simulation and modelling mathematical equation. Phase 2 is about understanding voltage- mode control with simulation. The comparison will be made between the current-mode control and voltage-mode control and the validation of simulation result is in Phase 3. The last phase is analyzing the result and makes certain conclusion based on the findings. In addition, other control topologies are also compared like the hysteresis controller. Even though hysteresis is advance and complex, this project just put more focus on current-mode control. As a conclusion, the current-mode control is better than voltage-mode control in term of voltage ripple and inductance current ripple.

ABSTRAK

Salah satu sebab mengapa DC -DC penukar digunakan secara meluas dalam industri pada masa kini adalah kerana pentingnya voltan yang stabil atau voltan terkawal bertujuan untuk DC -DC penukar menstabilkan voltan. Penukar langkah-turun (step-down converter) atau penukar buck akan menghasilkan voltan keluaran yang nilainya kurang daripada nilai voltan masukkan. Secara lazimnya , topologi kawalan yang biasa digunakan ialah kawalan voltan mod dan kawalan arus mod. Dalam projek ini , kaedah kawalan yang digunakan adalah kawalan semasa mod penukar buck kerana mod kawalan ini adalah lebih tepat nilai simulasinya berbanding kawalan voltan mod. Kawalan semasa mod adalah lebih baik dan tepat kerana ia mempunyai tindak balas yang lebih baik. Kawalan semasa mod mempunyai tindak balas lebih baik kerana dalam kawalan semasa mod sensor mempunyai perubahan rasa beban semasa terus jadi ralat voltan penguat tidak ada keperluan untuk bertindak balas dan membuat pembetulan sebelum menghasilkan voltan kawalan. Objektif utama dan skop projek ini adalah untuk mereka-bentuk puncak kawalan semasa mod penukar buck . Projek ini juga akan mengkaji mengenai penukar buck puncak kawalan semasa mod dan kemudian ia akan simulasi menggunakan perisian Pspice. Projek ini dijalankan di bawah beberapa fasa . Fasa 1 adalah pengenalan dan pemahaman mengenai kawalan semasa mod dengan simulasi dan pemodelan persamaan matematik . Fasa 2 adalah mengenai pemahaman kawalan voltan mod dengan simulasi. Perbandingan akan dibuat antara kawalan semasa mod dan kawalan voltan mod dan pengesahan keputusan simulasi adalah dalam Fasa 3. Fasa terakhir adalah menganalisis keputusan dan membuat kesimpulan tertentu berdasarkan dapatan kajian. Di samping itu, topologi kawalan lain juga seperti topologi histeresis juga turut sama dibuat perbandingan . Walaupun histeresis adalah lebih moden dan kompleks , projek ini hanya meletakkan tumpuan lebih kepada kawalan semasa mod. Kesimpulannya, kawalan semasa mod adalah lebih baik daripada kawalan voltan mod dari segi riak voltan dan riak semasa aruhan .

TABLE OF CONTENT

CHAPTER	TITLE	PAGES
	SUPERVISOR APPROVAL	i
	STUDENT DECLARATION	ii
	STUDENT DEDICATION	iii
	ACKNOWLEDGEMENTS	iv
	ABSTRACT	v
	ABSTRAK	vi
	TABLE OF CONTENT	vii
	LIST OF TABLES	x
	LIST OF FIGURES	xi
	LIST OF APPENDICES	xiv
CHAPTER 1	INTRODUCTION	
1.1	Project Background	1
1.2	Problem Statement	2
1.3	Objectives	3
1.4	Scope	3
1.5	Report Outlines	3
CHAPTER 2	LITERATURE REVIEW	
2.1	Theory and Basic Principle	5
2.1.1	DC-DC Converter	5

2.1.1.1	DC-DC Converter- Buck Converter	7
2.1.1.2	Operation of Buck Converter	8
2.1.1.3	Design of Buck Converter	12
2.1.2	Voltage-Mode Control	14
2.1.3	Current-Mode Control	15
2.1.4	Compensator	19
2.1.4.1	Type II Compensator	19
2.1.4.2	Type III Compensator	23
2.1.4.3	The K-Factor Concept	25
2.2	Previous Problem	26
2.3	Summary of Review	29

CHAPTER 3

DESIGN METHODOLOGY

3.1	Project Activity	30
3.1.1	Flowchart	33
3.2	Simulation	34
3.2.1	Mathematical Modeling	34
3.2.1.1	Buck Converter State Equation	36
3.2.2	Power Stage Design	43
3.3	Simulation Design of Buck Converter Power Stage	46
3.4	Type II Compensator Design Procedure	47
3.5	Simulation Design Peak Current-Mode Control Of Buck Converter	52
3.6	Simulation Design Voltage-Mode Control Of Buck Converter	54

CHAPTER 4

RESULT AND DISCUSSION

4.1	Power Stage Buck Converter Result	56
4.2	Power Stage Buck Converter Compensator Result	60

4.3	Closed-Loop Buck Converter: Peak Current-Mode Control Result	66
4.4	Closed-Loop Buck Converter: Voltage-Mode Control Result	70
4.5	Discussion Of Buck Converter Simulation Result	74
CHAPTER 5	CONCLUSION AND RECOMMENDATION	76
5.1	Conclusion	76
5.2	Recommendation	78
	REFERENCES	79
	APPENDIX	80

LIST OF FIGURES

CHAPTER	TITLE	PAGES
CHAPTER 2	LITERATURE REVIEW	
Figure 2.1	DC-DC Converter Block Diagram	6
Figure 2.2	Buck Converter Stage Schematic	7
Figure 2.3	Basic Circuit Of Buck Converter	8
Figure 2.4a	ON State Of Buck Converter in Continuous Mode Operation	9
Figure 2.4b	OFF State Of Buck Converter in Continuous Mode Operation	9
Figure 2.5	Continuous Current Mode Buck Converter Power Stage Waveforms in term of Voltage and Current	10
Figure 2.6	Circuit Of Discontinuous Mode Buck Converter Power Stage	11
Figure 2.7	The Continuous Mode Of Buck Converter Power Stage Waveforms in term of Voltage and Current	11
Figure 2.8	The Buck Converter Power and Control Stage	14
Figure 2.9	Block Diagram Of Current-Mode Control	16
Figure 2.10	Type-II Compensator Circuit and Transfer Function	19
Figure 2.11	Type-II Compensator Bode Plot	20
Figure 2.12	Closed Loop System with Type II Network	21
Figure 2.13	The Asymptotic Bode Gain Plot and The Actual Gain And Phase Equations for the Type II Compensator	22

Figure 2.14	Generic Type III Compensator and Transfer Function	23
Figure 2.15	Type III Compensator Bode Plot	24
Figure 2.16	The Asymptotic Bode Gain for the Type III Compensated System and the Gain and Phase Equations	25
Figure 2.17	Plant Transfer Function for Buck Converter Using Voltage-Mode Control	26
Figure 2.18	Plant Transfer Function for a Buck Converter Using Current-Mode Control	28
CHAPTER 3	DESIGN METHODOLOGY	
Figure 3.1	Flowchart of Project Activity	33
Figure 3.2	Buck Converter Switch Closed Equivalent Circuit	37
Figure 3.3	Buck Converter Switch Open Equivalent Circuit	37
Figure 3.4	Power Stage Construction Circuit of Buck Converter	46
Figure 3.5	Open-Loop Response Transfer Function for Buck Converter from Command Window Matlab Software	50
Figure 3.6	Open-Loop Response Transfer Function At Crossover Frequency from Command Matlab	51
Figure 3.7	Peak Current-Mode Control of Buck Converter Construction Circuit Using Pspice Software	52
Figure 3.8	Voltage-Mode Control of Buck Converter Construction Circuit Using Pspice Software	54
CHAPTER 4	RESULT AND DISCUSSION	
Figure 4.1	Power Stage Buck Converter Result	58

Figure 4.2	Output Voltage Of Power Stage Buck Converter Result From Pspice Simulation Software	59
Figure 4.3	Output Current Of Power Stage Buck Converter Result From Pspice Simulation Software	60
Figure 4.4	Open-Loop Response for Buck Converter Result Bode Plot From Matlab Simulation Software	62
Figure 4.5	The Open-Loop Response for Buck Converter Result Bode Plot Read at Crossover Frequency	63
Figure 4.6	Output Result of Peak Current-Mode Control Of Buck Converter	66
Figure 4.7	Output Current Result Of Peak Current-Mode Control Buck Converter	67
Figure 4.8	Output Voltage Result Of Peak Current-Mode Control Buck Converter	68
Figure 4.9	Output Result of Voltage -Mode Control Of Buck Converter	70
Figure 4.10	Output Current Result Of Voltage-Mode Control Buck Converter	71
Figure 4.11	Output Voltage Result Of Voltage-Mode Control Buck Converter	72

CHAPTER 1

INTRODUCTION

This chapter describes the project background, problem statements, project objectives and project scope. In this project background, it will brief the description of the buck converter, peak current-mode control and voltage-mode control of buck converter as well as the project objectives and project scopes.

1.1 Project Background

The switched mode dc-dc converters are widely used to provide power processing for many applications because of the switched mode dc-dc converters are able to convert one level of electrical voltage into another level by switching action that some of simplest power electronic circuits. For dc-dc converter the main objectives are stability, zero steady-state error, specifies transient response to step change in reference and step change in disturbance inputs which are load and input voltage. There have several dc-dc converter switching controller topologies named as current-mode control and voltage-mode control. Every topology has some advantages and disadvantages, surely the simple, excellent performances under any condition and low cost structure of controller will be chosen.

The main idea of this report is to develop peak current-mode control of buck converter. Current-mode control has a fast response and divided to two types of control mode which are peak current-mode control and average current mode control. Average mode-current control is

better than peak current-mode control in term of accuracy which average current-mode control more accurate. In this project, peak current-mode control will be chosen because of low cost and simple circuit design. To make the controller become more stable, type II compensator has been chosen in circuit structure. To enhance the research, by in the end of project peak current-mode control will be compared with voltage-mode control of buck converter in term of output voltage ripple and inductance output current ripple. Simulation of circuit will be done by using Pspice simulation software.

1.2 Problem Statement

DC –DC converter switching controller consists of many control topologies to generate switching signal. Some of the switching signals includes of voltage-mode control or current-mode control. Current-mode control has better respond than voltage-mode control because has sense change in load current directly so that voltage error amplifier does no need to react and make a correction. Meanwhile voltage-mode control has slow response because a load current change on the output voltage so that voltage error amplifier can react and make correction. Sensing of voltage-mode control is poorer compare to sensing of current-mode control because in voltage-mode control is only containing single feedback loop from output voltage which is outer loop. This also called single sensing. Current-mode control have double sensing and double loop called outer loop which is slower compare to inner loop. Inner loop is controlled by inductor current in current-mode control which does not exist in voltage-mode control Current-mode control can be divided into two which are peak current-mode control and average current-mode control. Peak current-mode control is easy to design and has low cost implementation compare to the average current-mode control.

1.3 Objectives

The objectives of the projects are:

- i. To design peak current-mode control of buck converter
- ii. To do the simulation for peak current-mode control of buck converter circuit using Pspice software
- iii. To do comparison of performance between peak current-mode control and voltage-mode control in term of voltage ripple and inductance current ripple.

1.4 Scope

- i. In this project, the power stage converter that will be designed is buck converter circuit which the input will be 30V and the output is 15V. Controller mode that will be used for the buck converter circuit is peak current-mode.
- ii. Type II compensator will be used as error amplifier for the circuit.
- iii. The circuit is simulated by using Pspice software and its performance will be compared with voltage-mode control buck converter in terms of voltage ripple and inductance current ripple.

1.5 Report Outline

Chapter 1

This chapter will discuss and explain the background of the project with problem statements, objectives and also the scope. Peak current-mode control, voltage-mode control and Pspice software are the main essential in this project.

Chapter 2

This chapter will focus on literature review for those there parts that have been explain in Chapter 1. All the journals and books that have some attachment to this project are used as a reference to guide and help to completing this project. Each of this part is explained based on this finding.

Chapter 3

This chapter will discuss and explain about the methodology that has been used in order to complete this project. The project activity is to describe the flow of whole project as stated in the project flowcharting. The major part in this chapter which is the software simulation designed. The discussion will be focused on how to design and simulate in Pspice software of the buck converter, using current-mode and voltage-mode control. Another area is the compensator design through Matlab simulation software.

Chapter 4

Discuss about the result obtained and limitation of the project. All discussion are concentrating on the result and comparing with the simulation between current-mode control and voltage-mode control.

Chapter 5

This chapter will discuss about the conclusion of the development of the project. This chapter also discusses the recommendation for this system for future development or modification and discuss about costing and commercialization.

CHAPTER 2

LITERATURE REVIEW

This chapter describes all of the related theories and literature reviews of the buck converter, peak current-mode control and voltage-mode control of the buck converter. This chapter also discuss about previous problem of the current-mode control and voltage-mode control of buck converter.

2.1 Theory and Basic Principle

2.1.1 DC-DC Converter

DC-DC converter is one of electronic devices used to change DC electrical power efficiency from one voltage level to another. DC-DC converter is need because it is not same like AC which DC cannot simply be stepped up or down using a transformer. In many ways, a DC-DC converter is the DC equivalent of a transformer [1]. Almost DC-DC converters have same function as transformer that essentially just change the input energy into a different impedance level. The output power all comes from the input and there is no energy manufactured inside the

converter no matter what the output voltage level. The converter often includes one or several transistor in order to control the output voltage. The transistor is not operated in its linear interval because the converters are desirably made with low losses. When time the transistor is off, the current through it is low and the power loss is also low. Resistors are avoided in the converters when to obtain low losses.

Capacitors and inductors are used since it ideally does not have any losses. Figure 2.1 shows the DC-DC converter blocks diagram. To step up or stepped down the voltage, the non-isolating type of converter is generally used by a relatively small ration and there is no problem with the output and input having no dielectric isolation. There are five main types of converter in this non-isolating group usually called the buck, boost, buck-boost, and Cuk and charge-pump converters. The buck converter is used for voltage step-down or reduction while the boost converter is used for voltage step-up. The Cuk and Buck-Boost converters can be used for either step-up or step-down but are essentially voltage polarity reverses or inverters as well. The charge-pump converter is used for either voltage inversion or voltage step-up but only in relatively low power applications [1].

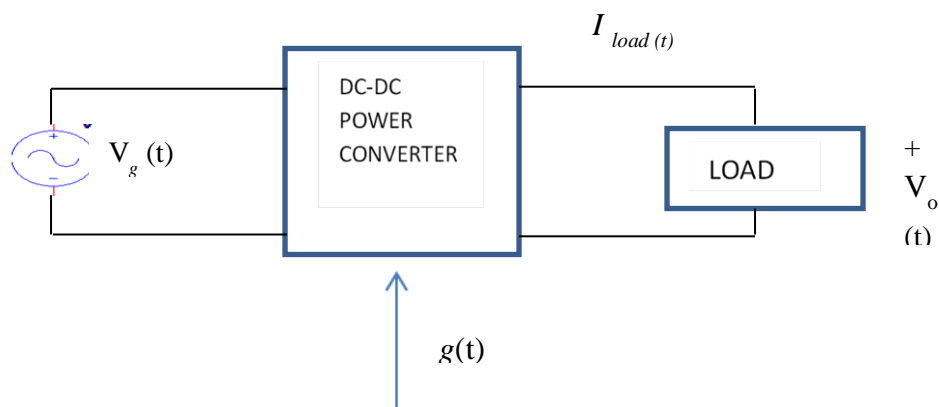

Figure 2.1: DC-DC Converter Block Diagram [1]

2.1.1.1 DC-DC Converter- Buck Converter

The popular non-isolated power stage topology which is buck converter, sometimes called a step-down power stage. Buck power stage is suitable for any design because the required output is always less than the input voltage [2]. The input current for a buck power stage is pulsating or discontinuous because the power switch current that pulses from zero input output every switching cycle. The output current for a buck power stage is non-pulsating or continuous because the output current is supplied by the output inductor or capacitor combination. Figure 2.2 shows a simplified schematic of the buck power stage. Capacitor and inductor, L makes up the effective output filter. The inductor dc resistance and the capacitor equivalent series resistance are included in the analysis. Resistor represents the load seen by the power supply output. The diode is usually called the freewheeling diode or catch diode.

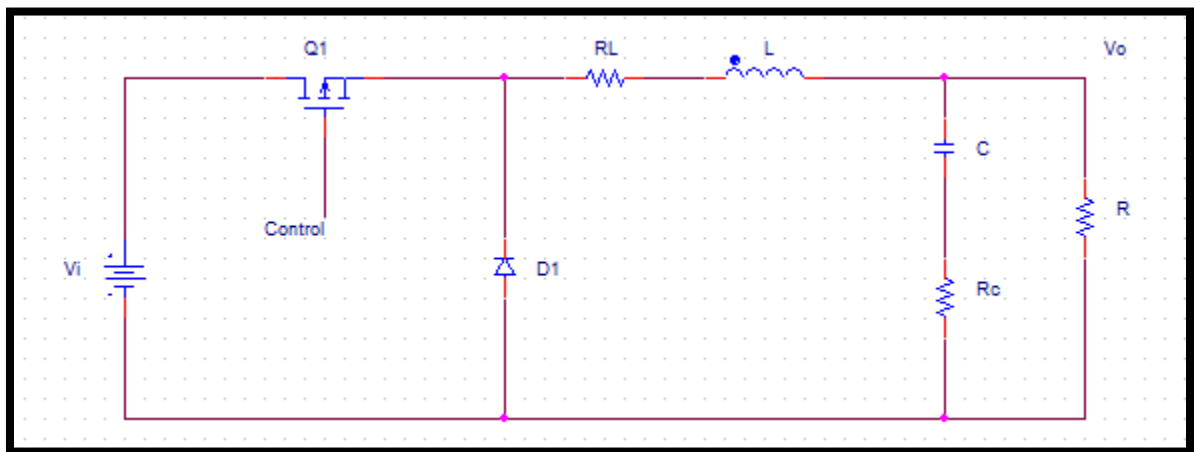

Figure 2.2: Buck Power Stage Schematic [2]

A power stage can operate in discontinuous or continuous inductor current mode [2]. Current flows continuously in the inductor during the entire switching cycle in steady-state operation in continuous inductor current mode. While in discontinuous inductor current mode, inductor current is zero for a portion of the switching cycle. This cycle starts at zero, reaches peak value and return to zero during each switching cycle. It is desirable for a power stage to

stay in only one mode over its expected operating conditions because the power stage frequency response changes significantly between the two modes of operation.

2.1.1.2 Operation of Buck Converter

Buck converter is able to produce a dc output voltage smaller in magnitude than the dc input voltage level with minimal ripple. It is a switched-mode power supply that uses two switches like a diode and transistor as well as a capacitor and inductor. The basic circuit of buck converter shows in Figure 2.3 [3].

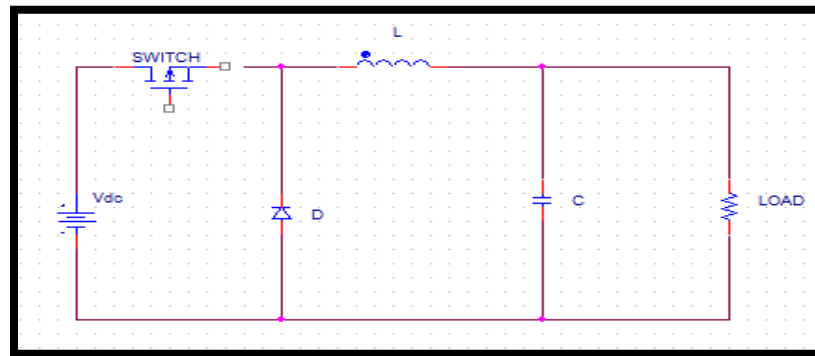
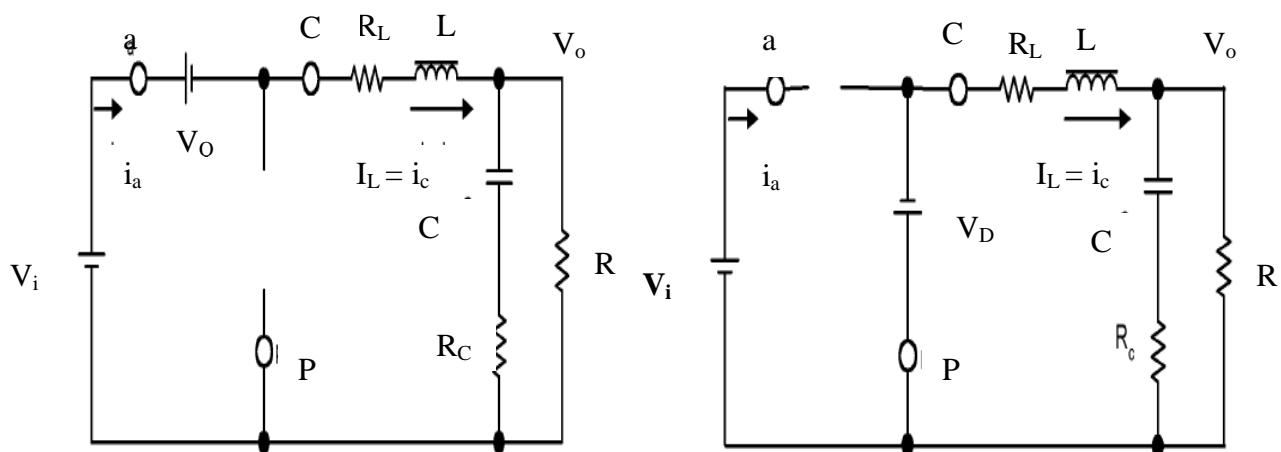

Figure 2.3: Basic circuit of Buck Converter [3]

Current in the circuit is zero at early because of the switch in the circuit in open position. When switch is closed, the current begin increase. During that time the inductor doing its job by storing energy in form of magnetic field, at the same time the inductor decreasing the voltage same as net voltage seen by the load. Then the switch is opened before the voltage drop to zero because of inductor allowed all of the current to pass through. At this time the inductor will be acting like a voltage source in order to maintain the current and also to provide the same net voltage to the load when the input source is not connected into the circuit and current will drop. If the switch is closed again before the inductor fully discharges, the load will not see a non-zero voltage [3].

The operation of buck converter has two modes which is discontinuous and continuous mode. The buck power stage assumes two states per switching cycle in continuous current mode. In the ON state, Q1 is on and D1 is off. In the OFF state, Q1 is off and D1 is on. Each of the two states of buck converter can be representing in a simple linear circuit where the switches in the circuit are replaced by the equivalent circuit during each state. Figure 2.4 shows the linear circuit diagram for each of the two states and Figure 2.5 shows the continuous current mode buck power stage waveforms in terms of voltage and current [3].



2.4 a: ON state of Buck converter in Continuous mode operation [3]

2.4 b: OFF state of Buck converter in Continuous mode operation [3]

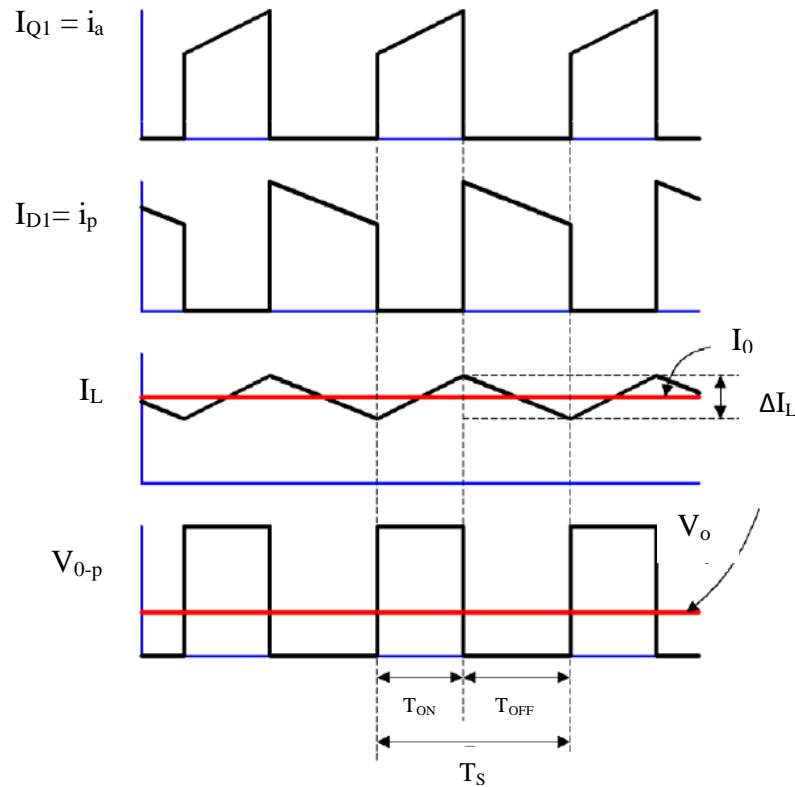

Figure 2.5: Continuous current mode buck power stage waveforms in terms of voltage and current [3]

It occurs for light loads or low operating frequencies where the inductor current eventually hits zero during the switch open state in discontinuous mode. To prevent backward current flow, the diode will open. The small capacitances of the diode and MOSFET, acting in parallel with each other as a net parasitic capacitance, interact with inductor to produce an oscillation. The output capacitor is in series with the net parasitics capacitance but the capacitor is so large. When the capacitor is so large, it can be ignored in the oscillation phenomenon. Figure 2.6 shows the circuit of discontinuous mode of buck power stage converter and Figure 2.7 shows the discontinuous mode buck power stage waveforms in terms of voltage and current [3].

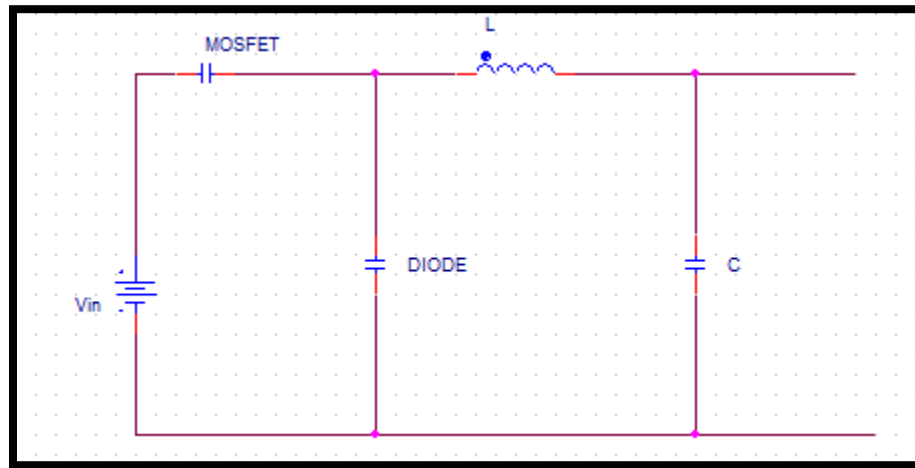

Figure 2.6: Circuit of discontinuous mode of buck power stage converter [3]

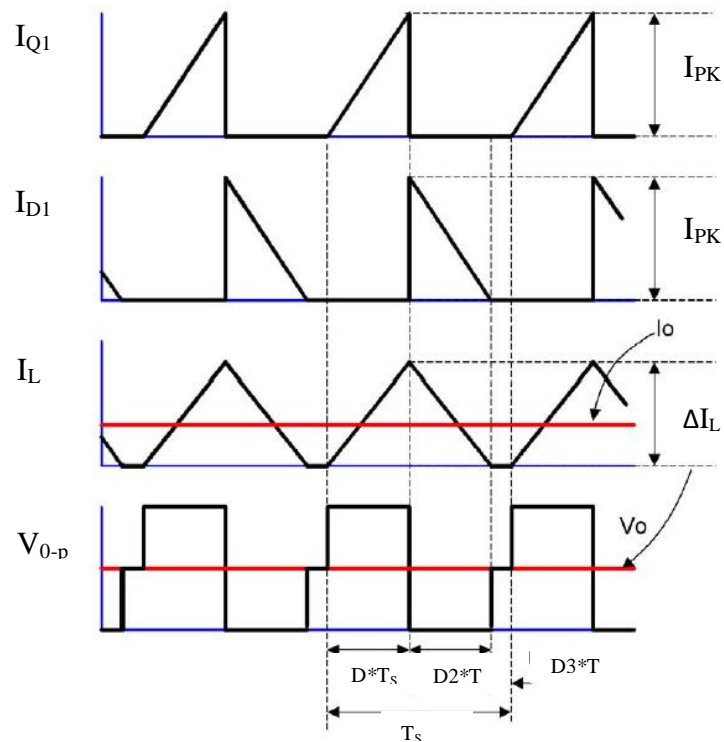

Figure 2.7: The discontinuous mode buck power stage waveforms in terms of voltage and current [3]

2.1.1.3 Design of Buck Converter

A few considerations must be noted in order to design buck converter. Most buck converters are designed for continuous-current operation. When the switching frequency increases, the minimum size of the inductor to produce continuous current and the minimum size of capacitor to limit output ripple both decrease. At the same time, high switching frequencies are desirable to reduce the size of both the inductor and the capacitor. The tradeoff for high switching frequencies is increased power loss in the switches. Increased power loss in the switches means that heat is produced. This heat produced will decrease the converter's efficiency and may require a large heat sink, offsetting the reduction in size of the inductor and capacitor. Typical switching frequencies need to avoid audio noise. For high-current and low-voltage applications, the synchronous rectification is preferred over using a diode for the second switch.

The voltage across the conducting MOSFET will be much less than that across a diode and resulting in lower losses. To ensure continuous current operation, the inductor value should be larger than minimum inductor. The inductor wire must be rated at the rms current and the core should not saturate for peak inductor current. To the design specification to withstand peak output voltage and to carry the required rms current, the capacitor must be selected to limit the output ripple. The diode and switch must withstand maximum voltage stress when off and maximum current when on. The temperature ratings must not be exceeded often requiring a heat sink. Assuming ideal switches and an ideal inductor in the initial design is usually reasonable. In addition, the equivalent series resistance (ESR) of the capacitor should be included because it typically gives a more significant output voltage ripple than the ideal device and greatly influences the choice of capacitor size [4].

Important part in design this converter is by specifying the input and output voltage of converter. Then find the duty ratio, D by using Equation 2.1 [5]

$$V_O = V_S D \quad (2.1)$$

The next step is finding the average inductor current which is same with average current in the load resistor as Equation 2.2 [5]

$$I_L = I_R = \frac{V_o}{R} \quad (2.2)$$

Since the value of inductor current is known at Equation 2.2, the minimum and maximum values of inductor current are calculated as

$$I_{MAX} = I_L + \frac{\Delta i_L}{2} = \frac{V_o}{R} + \frac{1}{2} \left[\frac{V_o}{L} (1-D) T \right] \quad (2.3)$$

$$I_{MIN} = I_L - \frac{\Delta i_L}{2} = \frac{V_o}{R} - \frac{1}{2} \left[\frac{V_o}{L} (1-D) T \right] \quad (2.4)$$

The next step in design buck converter is by calculating the minimum inductance that required for continuous current.

$$L_{MIN} = \frac{(1-D)R}{2f} \quad (2.5)$$

The value of inductance must greater than L_{MIN} because to make sure that continuous current occurred in practical. Value of inductor current must be 25% of value minimum inductor. Assuming all the inductor ripple current flows through output capacitor and equivalent series resistor for output capacitor is zero and the value of capacitor can be calculated by Equation 2.6 [5]

$$C = \frac{(1-D)}{8L \left(\frac{\Delta V_o}{V_o} \right) f^2} \quad (2.6)$$

2.1.2 Voltage-Mode Control

Voltage-mode control is also known as the voltage feedback arrangement when applied to DC-DC converter. Voltage mode control is an easy way to design and implement and has good element to disturbance at the references input and it only contain single feedback loop from output voltage. Figure 2.8 shows the buck converter power and control stage [6].

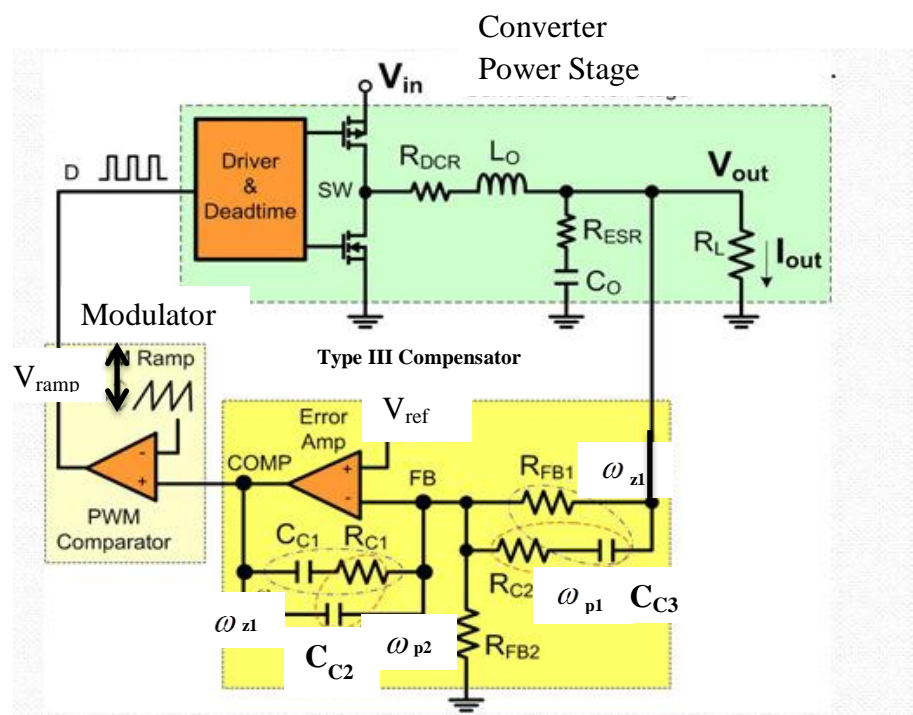

Figure 2.8: The Buck Converter Power and Control Stage [6]

Non-ideal power train components are shown with parasitics such as capacitor equivalent series resistance, R_{ESR} denoted explicitly and inductor DC resistance, R_{DCR} . Second order parasitics such as interconnection impedances and capacitor equivalent series inductance (ESL) are not represented. The high side switch is driven by a PWM signal for time t_{on} in each switching period of duration T_s . The duty cycle ration, D is given by Equation 2.7 [6]

$$D = \frac{t_{on}}{T_s} \approx \frac{V_{out}}{V_{in}} \quad (2.7)$$

The low side switch is driven complementarily with duty cycle $D' = 1 - D$. Both switches of voltage-mode operate at fixed switching frequency $f_s = 1/T_s$. The output filter consists of capacitor, C_o and inductor, L_o . A conventional operational amplifier type voltage error amplifier represents the epicenter of the control loop structure. The divided down output voltage at the error amplifier inverting input is usually termed the feedback node is compared to a fixed reference voltage and a compensated error signal is generated at the compensation node. This error signal is compared to a saw-tooth ramp voltage at the pulse width modulator comparator like an increase in compensation node leads to a commensurate increase in duty cycle command for the power stage. [7].

2.1.3 Current-Mode Control

There are three things to consider which current-mode operation, modulator gain is and slope compensation in current-mode control. Current-mode operation is an ideal current mode converter is only depending on the average or dc inductor current. The inner current loop turns the inductor into a voltage-controlled current source and effectively removing the inductor from the outer voltage control loop at dc and low frequency.

Modulator gain is dependent on the effective slope of the ramp presented to the modulating comparator input. Each modulating gain operating mode will have a unique characteristic equation for the modulator gain. Slope compensation is about the requirement for slope compensation which is dependent on the relationship of the average current to the value of current at the time when every sample is taken. In fixed-frequency operation, if the sampled current were equal to the average current, there would be no requirement for slope compensation.

The current-mode converter which uses peak, valley, average or sampled-and-hold can be categorized as secondary to the operation of current loop. As long as the dc current is sampled, current-mode operation will still maintained. The current-loop gain splits the complex-conjugate