

**WIRELESS POWER TRANSFER  
MONITORING**

**Ahmad Faiz Bin Ahmad Azahar**  
**Bachelor of Electrical Engineering**  
**(Control, Instrumentation & Automation)**

**JUNE 2014**

## SUPERVISOR'S ENDORSEMENT

“I hereby declare that I have read through this report entitle “*Wireless Power Transfer Monitoring*” and found that it has complied the partial fulfillment for awarding the Degree of Bachelor of Electrical Engineering (Control, Instrumentation and Automation)”

Signature : .....

Supervisor's Name : .....

Date : .....

**WIRELESS POWER TRANSFER MONITORING**

**AHMAD FAIZ BIN AHMAD AZAHAR**

**A report submitted in partial fulfilment of the requirements for the degree  
Of Electrical Engineering (Control, Instrumentation and Automation)**

**Faculty of Electrical Engineering**

**UNIVERSITI TEKNIKAL MALAYSIA MELAKA**

**2014**

## STUDENT DECLARATION

“I declare that that this reports entitle “*Wireless Power Transfer Monitoring*” is the result of my own research expect as cited in the references. The report has not been accepted for any degree and is not concurrently submitted in candidature of any other degree.

Signature : .....

Name : .....

Date : .....

## ACKNOWLEDGEMENT

In preparing this report, I was in contact with many people, researchers, academicians and practitioners. They have contributed towards my understanding and thought. In particular, I wish to express my sincere appreciation to my main project supervisor, Encik Ahmad Fairuz Bin Muhammad Amin, for encouragement, guidance critics and friendship. I am also very thankful to my lecturers who have been giving me guidance, advices and motivation. Without their continued support and interest, this project would not have been same as presented here.

I am also want to thanks my family whom giving support all the way of my studies and my University also deserve special thanks for their assistance in supplying the relevant literatures. My fellow friends should also be recognised for their support. My sincere appreciation also extends to all who have provided assistance at various occasions. Their views and tips are useful indeed. Unfortunately, it is not possible to list all of them in this limited space.

## **ABSTRACT**

Wireless power transfer is the transmission of electrical energy from power source to an electrical load without conductor attached to them. Wireless transmission is useful in case where interconnecting wire is inconvenient. The problem of wireless power transfer is different from wireless telecommunication such as radio. The proportions of energy received become critical only if it is too low for signal. The most common form of wireless power transfer is carried out using direct induction follow by resonant magnetic induction. In this project we are using resonant magnetic induction as coil of wireless power transfer. By using two types of wires, we need to see the performance transferring power each type of wire. We will only using copper wire and enamel copper wire.

## ABSTRAK

Penghantar kuasa tanpa wayar adalah penghantaran tenaga elektrik dari sumber kuasa kepada beban elektrik tanpa konduktor yang menyambung antaranya. Penghantar kuasa tanpa wayar berguna dalam kes di mana wayar bersambung adalah menyusahkan. Masalah pemindahan kuasa tanpa wayar berbeza daripada telekomunikasi tanpa wayar seperti radio. Perkadaran tenaga diterima menjadi kritikal hanya jika ia terlalu rendah untuk isyarat. Kebiasaannya, pemindahan kuasa tanpa wayar dijalankan menggunakan induksi sendiri dan diikuti salunan aruhan magnet. Dalam projek ini, kita menggunakan salunan aruhan magnet dengan menggunakan dua jenis wayar iaitu wayar tembaga biasa dan wayar enamel tembaga. Dengan menggunakan dua jenis wayar ini, kita perlu melihat prestasi pemindahan kuasa setiap wayar.

## TABLE OF CONTENT

<b>CHAPTER</b>	<b>TITLE</b>	<b>PAGE</b>
	<b>ACKNOWLEDGEMENT</b>	<b>IV</b>
	<b>ABSTRACT</b>	<b>V</b>
	<b>TABLE OF CONTENT</b>	<b>VII</b>
	<b>LIST OF TABLE</b>	<b>IX</b>
	<b>LIST OF FIGURE</b>	<b>X</b>
<b>1</b>	<b>INTRODUCTION</b>	
	1.1 Overview	1
	1.2 Project Motivation	2
	1.3 Problem Statement	2
	1.4 Objective	3
	1.5 Scope Of Project	3
	1.6 Report Outline	4
<b>2</b>	<b>LITERATURE REVIEW</b>	
	2.1 Overview	6
	2.2 Early History Of Wireless Power Transfer	6
	2.2.1 Heinrich Hertz	7
	2.2.2 Nikola Tesla	7
	2.3 Basic Principle Of Wireless Power Transfer	8



<b>3</b>	<b>METHODOLOGY</b>	
3.1	Overview	9
3.2	Project Flow Chart	10
3.3	Operating Principles	11
3.4	Magnetic Resonance Coupling	12
3.5	Labview	16
3.6	Wireless Power Transfer Circuit	17
3.7	Type Wire For Wireless Power Transfer Coil	18
3.7.1	Copper Wire Coil	18
3.7.2	Enamel Copper Wire Coil	19
<b>4</b>	<b>RESULT</b>	
4.1	Overview	20
4.2	Experiment Transfer Power Using Normal Copper Wire	20
4.3	Experiment Transfer Power Using Enamel Copper Wire	26
<b>5</b>	<b>ANALYSIS AND DISCUSSION</b>	
5.1	Overview	32
5.2	Analysis Of Power Transfer	32
5.3	Efficiency Of Resonance Coil	36
5.3.1	Percentage Normal Copper Coil	36
5.3.2	Percentage Enamel Copper Coil	37
<b>6</b>	<b>CONCLUSION AND RECOMMENDATION</b>	
6.1	Overview	39
6.2	Conclusion	39
6.3	Recommendation	40
	<b>REFERENCE</b>	<b>41</b>

**LIST OF TABLES**

<b>TABLE</b>	<b>TITLE</b>	<b>PAGE</b>
Table 4.1	Voltage vs Distance for normal copper wire.	21
Table 4.2	Voltage vs Distance for Enamel Copper Wire.	26
Table 5.1	Voltage vs Distance for Normal Copper Wire Coil.	32
Table 5.2	Voltage vs Distance for Enamel Copper Wire Coil.	33
Table 5.3	Difference Voltage between the Coils.	34
Table 5.4	Efficiency of Copper Wire Coil vs Distance	36
Table 5.5	Efficiency of Enamel Copper Wire Coil vs Distance.	37

## LIST OF FIGURES

<b>FIGURE</b>	<b>TITLE</b>	<b>PAGE</b>
Figure 1.1	Comparison of using wire charging and wireless power transfer charging.	3
Figure 2.1	Basic Block Diagram of Wireless Power Transfer.	8
Figure 3.1	Flow chart for the methodology of the Project.	10
Figure 3.2	Block diagram of wireless power transfer system	11
Figure 3.3	Example of a resonator	12
Figure 3.4	Solenoid form for coil	13
Figure 3.5	Equivalent circuit for the couple resonator	15
Figure 3.6	Example UI component in LabVIEW.	16
Figure 3.7	Circuit from Proteus before etching.	17
Figure 3.8	Circuit receiver from Proteus before etching.	17
Figure 3.9	Circuit for wireless power transfer.	18
Figure 3.10	Normal Copper Wire	19
Figure 3.11	Enamel Copper Wire	19
Figure 4.1	Copper wire at transmitter using LabVIEW.	21
Figure 4.2	Copper wire at receiver using LabVIEW.	22
Figure 4.3	Copper wire at transmitter.	22
Figure 4.4	Copper wire at receiver at distance 0cm.	23
Figure 4.5	Copper wire at receiver at distance 2 cm.	23
Figure 4.6	Copper Wire at receiver at distance 4 cm.	24
Figure 4.7	Copper Wire at receiver at distance 6 cm.	24

Figure 4.8	Copper Wire at receiver at distance 8 cm.	25
Figure 4.9	Copper Wire at receiver at distance 10 cm.	25
Figure 4.10	Enamel wire at transmitter using LabVIEW.	27
Figure 4.11	Enamel wire at receiver using LabVIEW.	27
Figure 4.12	Enamel wire at transmitter.	28
Figure 4.13	Enamel wire at receiver at distance 0 cm.	28
Figure 4.14	Enamel wire at receiver at distance 2 cm.	29
Figure 4.15	Enamel wire at receiver at distance 4 cm.	29
Figure 4.16	Enamel wire at receiver at distance 6 cm.	30
Figure 4.17	Enamel wire at receiver at distance 8 cm.	30
Figure 4.18	Enamel wire at receiver at distance 10cm	31
Figure 5.1	Visual Difference Voltage from Table 5.3.	35
Figure 5.2	Different Voltage at receiver of two type wire coil.	35
Figure 5.3	Efficiency of Copper Wire Coil vs Distance	37
Figure 5.4	Efficiency of Enamel Copper Wire Coil vs Distance.	38
Figure 5.5	Difference Efficiency of Each Type of Coil.	38

## CHAPTER 1

### INTRODUCTION

#### 1.1 Overview

Nowadays technologies growing rapidly and many of the companies produce the latest gadget that suits in modern world. People will buy the gadget to make their life comfortable. Many of gadgets at certain area will face a problem of having many wires that sharing a limited amount of power socket, it also will make the wires become unmanageable and scattered. Hence, with the idea of Nikola Tesla, wireless power transfer is invented.

Wireless power transfer can be applied or used in our daily live to get more manageable or tidy area that free of wires. It also can be used in other area such as medical machine, industrial machine, electric car and other things. Wireless power transfer is easy to manage without affecting user health.

In this chapter will be discussing on project motivation, project objective, problem statement, scope of project.

## 1.2 Project Motivation

The motivation for wireless power transfer system comes from wires complex and untidy. With a large number of gadgets are using nowadays that focus on smartphone, there are demands for convenience in managing their power supplies. Other than that, it can help user easily to use technology at anywhere and anytime without worrying their battery draining quickly on their smartphone.

## 1.3 Problem Statement

Most of the people use gadgets to improve their daily routine work. Most of the gadget are using power socket as their power supply. If they use too many gadgets in their daily life it will cause lack of power socket. Nowadays, people are using smartphone to make their life easier. The problem they facing are the life time or standby time of smartphone battery is draining quickly with using multi-application usage. To overcome the problem is wireless power transfer were invented by Nikola Tesla in 1893, where he demonstrate the illumination of vacuum bulb without using wires. Wireless power transfer is used for exchanging the power through the resonance coil. Figure 1.1 shows the comparison of using wire charging and wireless power transfer charging. The difference is the wireless power transfer charging is more tidy and manageable, it also make user more comfortable to using smartphone without charging using wires.

The problem need to be highlight in this project are does the wireless power transfer can transferring power in the long range or only for a short range. Then, the performance of wireless power transfer can be effect from the material that been used in coil.

Wireless power transfer needs to be implemented in our life. It will make people use gadget for better life. In this project, an experiment need to carried out on analytical and prove the wireless power transfer can be used and also to get the efficiency of wireless power transfer.

In other hand, we need to consider the health environment of radiation of wireless power transfer.



Figure 1.1: Comparison of using wire charging and wireless power transfer charging.

## 1.4 Objective

There are several objectives that need to be achieved in order to make this project successfully.

- To investigate a wireless power transfer system using a resonant coil.
- To develop and study the system and test it to establish its functionality.
- To validate the performance coil of wireless power transfer using LabVIEW Software.

## 1.5 Scope of the project

The scope of this project is:

- Using only normal copper wire and enamel copper wire to do resonant coil on the existing circuit that had been commercialized.

- Develop the wireless power transfer system using a hardware and analytical by using existing circuit that had been commercial.
- The project only focused performance of the system with two type of material on the coil.

## 1.6 Report Outline

In this section, the outline of project report is presented. This report includes of five chapters and each chapter is explained.

**Chapter 1** discusses on introduction regarding to the wireless power transfer system. The problem statement, objectives and significant of project are stated briefly and clearly.

**Chapter 2** discusses the literature review on wireless power transfer systems. History of wireless power transfer.

**Chapter 3** discussing more about the methodology of wireless power transfer system. The flow charts of project are listed by following the sequence in phase 1 and phase 2.

**Chapter 4** representing the result from an experiment of normal copper wire coil and enamel copper wire coil.

**Chapter 5** representing the analysis of result by functionality and validate the performance using an LabVIEW that will be represent in graph (Voltage vs. Distance)



**Chapter 6** is the conclusions on the whole project done and also the recommendation for improving the future works.

## CHAPTER 2

### LITERATURE REVIEW

#### 2.1 Overview

Wireless power transfer system has been attempted many times throughout the last past centuries. The concept ideas were began from the experimented of Heinrich Hertz and Nikola Tesla around year 1890's and has continued until this day. Although Nikola Tesla was confident with his hypothesis to transfer power and nobody has been able to validate the idea. Nowadays, wireless power transfer is largely exhibited through induction. Although the functional of wireless power transfer through induction is constrained to a very small distances. In this chapter provides a literature review of history of wireless power transfer.

#### 2.2 Early History of Wireless Power Transfer

The early history of wireless power transfer involves of two main inventors namely Heinrich Hertz and Nikola Tesla.

### 2.2.1 Heinrich Hertz

Heinrich Hertz was born in Hamburg, Germany on 22<sup>th</sup> February 1857. Heinrich Hertz was gifted not only in school but also as a mechanic, sculptor, draftsman, linguist, and athlete (Susskind 1988). Heinrich Hertz studied at numerous university, most prominently studying at the university of Berlin under Hermann Helmholtz (Susskind, 1988). Hertz proved that electricity can be transmitted in electromagnetic waves. Heinrich Hertz died on 1<sup>st</sup> January 1894 at the age of 36. [2]

### 2.2.2 Nikola Tesla

Nikola Tesla was born in the stroke of midnight 9<sup>th</sup> July 1856 in Yugoslavia. Nikola Tesla had a special give of being able to imagine things so well that they seemed real. This allows him to build mental rather than physical prototypes that led to successful finished designs. The downside to this was that Nikola Tesla took very poor notes, he only wrote down those things that he deemed absolutely necessary. Nikola Tesla was far beyond his time in his experimentations. It wasn't until 1970 that Robert Golka became the first to replicate the Tesla coil.

In 1899, Nikola Tesla went to Colorado Springs to build a laboratory and try out some new ideas. One of these ideas was the wireless transmission of power. In his experiment he was able to light 20 lamps, 26 miles away from his lab.

Nikola Tesla theory of wireless transmission of power was a little different than today's vision; it was centred on his consideration of the earth as a giant conductor. Nikola Tesla died on 7<sup>th</sup> January 1943. [3]

### 2.3 Basic Principles of Wireless Power Transfer.

Radio was invented by a person name Nikola Tesla also known “Father of Wireless”, [1] he is the one who the first person that conceived the idea of transmitting power through the air has been around for over century, with the Nikola Tesla’s pioneer idea and his experiments attempts to do so. Most of the approaches to wireless power transfer are using an electromagnetic (EM) field of some of frequency as the means by which the energy is sent. [1] Figure 2.1 shows the simple block diagram of wireless power transfer.

There are three type of wireless power transfer that can use in wireless power transfer that is radiative transfer, inductive coupling and resonant coupling. [4] Radiative transfer are suitable to exchange information and transfer a small power in miliwatts, most of it were wasted into free space. For inductive coupling, it can be transmitted the power with high efficiency but in very short distance.

Last type is resonant coupling, it can transfer high power at medium distance. Basic principle is that two separate coils with the same resonant frequency are possible to form a resonant system based on high frequency magnetic coupling and exchange power in high efficiency. [4]

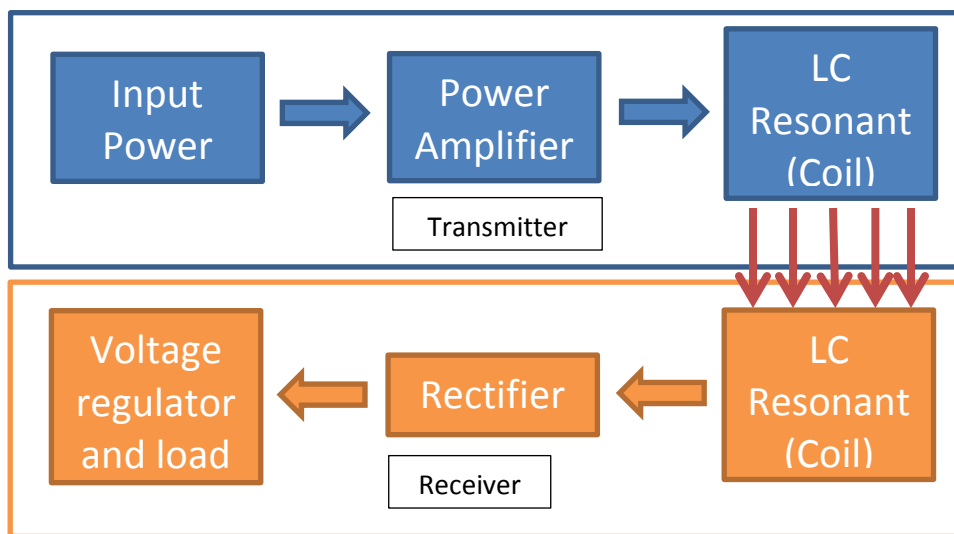

Figure 2.1: Basic Block Diagram of Wireless Power Transfer.

## CHAPTER 3

### METHODOLOGY

#### 3.1 Overview

In this chapter the main topics that will be discussed is the methodology and approaches used to complete this project. In this experiment, loop coils, and the performance wireless power transfer system will be analysed. This topic will consist:

- i. Project flow chart
- ii. Case study wireless power transfer using magnetic resonance coupled.
- iii. Experiment on wireless power transfer coils
- iv. Develop the system and validate the performance.
- v. Analyse result
- vi. Result and analysis

### 3.2 Project Flow Chart

Figure 3.1 show the project flow chart used to make sure this project is successfully done before the due date of this project:

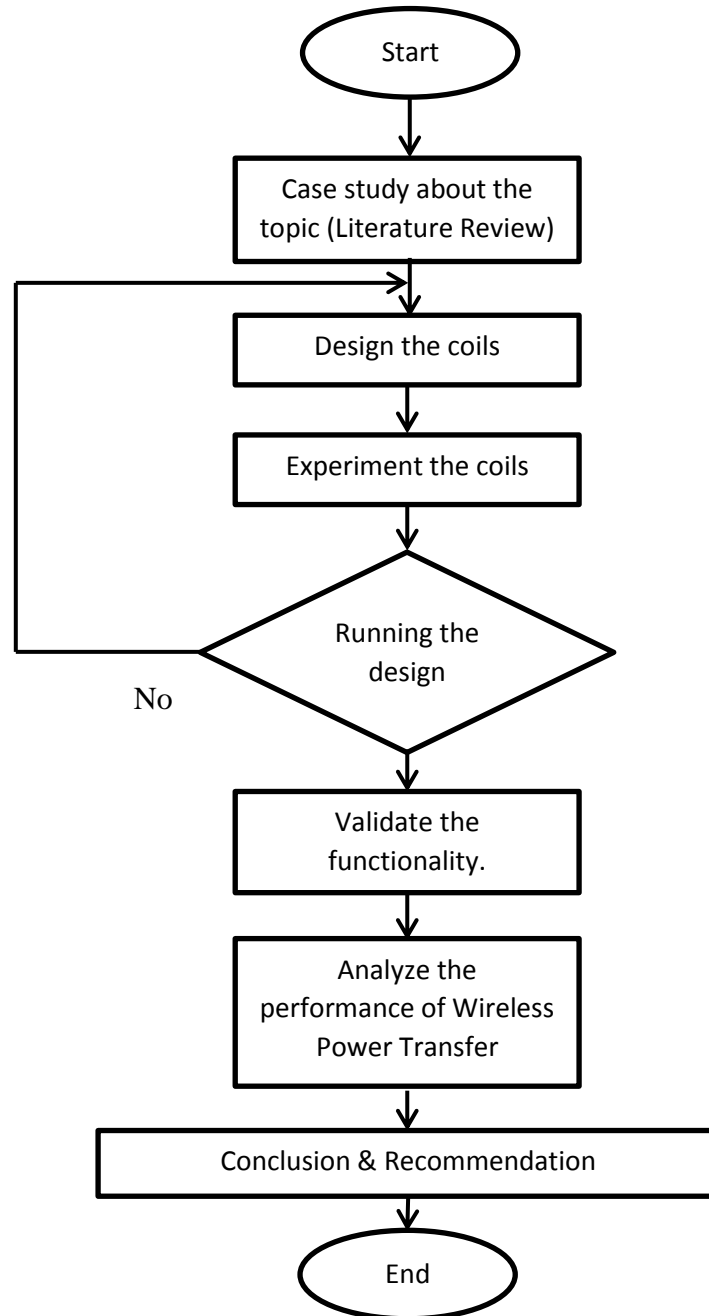

Figure 3.1: Flow chart for the methodology of the Project.

### 3.3 Operating Principles

The principles of operation of wireless power transfer system are very similar to the surface based wireless power transmission system used for communication within robot swarms [9]. In a resonant system, the circular current in the resonant coil is greater than the drive coil by the quality factor,  $Q$ . Wireless power transfer system circuit use power MOSFET to get a desired transfer frequency. Figure 3.2 show the block diagram of wireless power transfer transmitter.

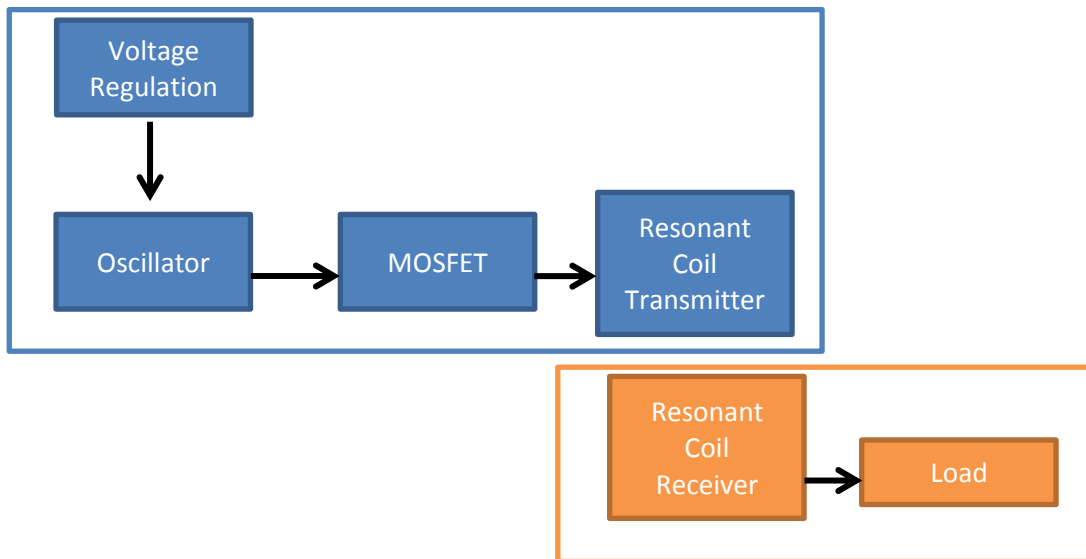

Figure 3.2: Block diagram of wireless power transfer system

A time varying current flows in a coil transmitter that is coupled with a resonance LC receiver coil. Current is induced in receiver coil at the transmission frequency, which set as resonance frequency. The resonance frequency can be calculated from the inductance and capacitance of LC circuit.

### 3.4 Magnetic Resonance Coupling

Resonance is a phenomenon that occurs in nature in many different forms, it involves energy oscillating between two modes. In a system at resonance, it possible to have large build-up of stored energy having only a weak excitation to the system and it occurs if the rate energy inject into the system is greater than the rate of energy loss by the system.[6] Figure 3.3 is the example circuit for resonator

The behaviour of an isolated resonator can be defined by two fundamental parameters, its resonance frequency,  $\omega_0$  and its intrinsic loss rate,  $\Gamma$ . The ratio of these two parameters define the quality factor or Q of the resonator ( $Q = \omega_0/2 \Gamma$ ) a measure of how well it stores energy.

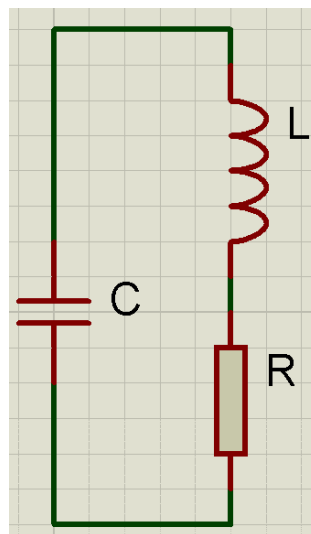

Figure 3.3: Example of a resonator

In this wireless power transfer will use magnetic resonance coupling method, this method has an advantage of transmit power in a long distance with a highly efficiency and robust to positional shift of transmitting and receiving antenna or also known coil. [4] The coil concept will be designed is solenoid.