



UNIVERSITI TEKNIKAL MALAYSIA MELAKA

**SIMULATION OF AUTOMATION OF PEN CAPPING
PROCESS FOR EK300 AT SPARKLE PRECISION SDN.
BHD.**

This report submitted in accordance with requirement of the Universiti Teknikal Malaysia Melaka (UTeM) for the Bachelor Degree of Manufacturing Engineering (Bachelor Degree of Manufacturing Engineering Process) (Hons.)

NOR MOHD UZAIR BIN NORSAHPERI

B051010229

890327045145

FACULTY OF MANUFACTURING

2014

“I hereby declare that I have read this thesis and in my opinion this thesis is sufficient in terms of scope and quality for the award of Bachelor of Engineering Manufacturing (Process)”.

Signature :

Name : Prof. Madya Dr Md Nizam Bin Abd Rahman

Date :

“I declare that this is my own work except for excerpts and summaries of each every one of them was me explain the source”.

Signature :

Name : Nor Mohd Uzair Bin Norsahperi

Date : 23 May 2014

DEDICATION

For my beloved family:

Norsahperi Bin Johari

Noor Hayah Bte Jantan

Nor Ashraf Bin Norsahperi (Brother)

Nor Ashafiq Bin Norsahperi (Brother)

Nor Mohd Haziq Bin Norsahperi (Brother)

And

BMFP's Students

ACKNOWLEDGEMENTS

First of all, I would like to express my appreciation and gratitude to Allah S.W.T for giving me the strength and ability to carry out the entire task and work given. It is with great pleasure and gratitude that I knowledge the many people whose expertise, advice, and encouragement contributed immensely toward the completion of my Final Year Project.

Many people have contributed to the success of my Final Year Project program. To begin with, I would like to thank my supervisor Prof Dr Md Nizam Bin Abd Rahman, factory supervisor, Mr Mohd Ali Hanapiah Mohamad Nor, like as Manager, Production SPSB and Assistant Manager, Production SPSB, Mr Nizaruddin Bin Haji Zakaria, who gave the most thorough and constructive support of my project.

My thanks and appreciation also goes to all technicians, my training friends and other SPSB staff, that had supplied thought, advice, challenges, criticism, help and suggestions that have influenced my performance and increase my knowledge and understanding upon completing my Final Year Project.

I would like to conclude this section by recognizing and thanking the many people in SPSB who had involved whether directly or indirectly towards the completion of my training.

ABSTRAK

Sparkle Precision Sdn Bhd menghasilkan alat-alat tulis untuk kegunaan pejabat. Antara produknya ialah setem dakwat, penanda , dan Penyerlah. Walau bagaimanapun, pengeluaran baris EK300 penanda pen boleh dijalankan dengan lebih cekap apabila dengan beberapa penambahbaikan. Barisan pemasangan untuk EK300 penanda pen terdiri daripada mesin automatik dan manual. Mesin manual pada barisan pemasangan kini tersekat operasinya. Dalam kajian ini , peningkatan dalam reka bentuk mesin dan, sistem mesin untuk mesin manual telah dicadangkan. Penambahbaikan yang dicadangkan dalam reka bentuk dan sistem menghasilkan penukaran kepada sistem automatik sepenuhnya. Cadangan kajian ini reka bentuk mesin baru dengan menggunakan perisian Solidwork . Simulasi sistem automatik yang dicadangkan baru telah dijalankan juga menggunakan Solidwork yang mana masa kitaran dianggarkan . Reka bentuk sistem mesin yang dicadangkan telah simulasi menggunakan perisian CX Programmer . Berdasarkan simulasi, masa kitaran telah dikurangkan sebanyak 53%. Berdasarkan analisis ROI , pelaburan dapat dipulihkan dalam tempoh sebulan hasil pengeluaran menggunakan sistem automatik yang dicadangkan baru.

ABSTRACT

Sparkle Precision Sdn Bhd manufactures stationeries for office usage. Some of its products are ink stamp, marker, and highlighter. However, production line of EK300 marker pen can be run more efficiently when with some improvement. Current assembly line for EK300 marker pen consists of automated and manual machines. The manual machine on the assembly line is currently the bottleneck of the operation. In this research, improvement in machine design and machine system for the manual machines was proposed. The proposed improvement in design and system resulted in a conversion to a fully automated system. The study proposed the new machine design by the use of Solidwork software. Simulation of the new proposed automated system was carried out also using Solidwork by which the cycle time was estimated. The proposed machine system design was simulated using CX Programmer software. Based on the simulations, the cycle time was reduced by 53%. Based on the ROI analysis, the investment can be recovered within a month of production run using the new proposed automated system.

TABLE OF CONTENT

SUPERVISOR DECLARATION	i
STUDENT DECLARATION	ii
DEDICATION	iii
ACKNOWLEDGEMENT	v
ABSTRACT	vi
ABSTRAK	vii
TABLE OF CONTENT	viii
LIST OF TABLE	xi
LIST OF FIGURE	xii
CHAPTER 1: INTRODUCTION	1
1.1 Introduction.	1
1.2 Problem Statement	1
1.3 Objective	2
1.4 Scope	2
1.5 Gant Chart	3
CHAPTER 2: LITERITURE REVIEW	5
2.1 Company Background	5
2.2 Assembling Process of EK300	6

2.3	Approaches in Capping Process Implementation	10
2.3.1	Summary of Capping Process Implementation	12
2.4	Approaches in Automation Implementation	12
2.4.1	Summary of Automation review	14
2.5	Modelling of Automation System	14
2.5.1	Summary of Motion Design	17
CHAPTER 3: METHODOLOGY		18
3.1	Flow Chart of Methodology	18
3.2	Industrial Visit	20
3.3	Machine Design	22
3.4	PLC System Developing	23
3.5	Return of Investment Analysis	25
CHAPTER 4: RESULT AND DISCUSSION		26
4.1	Machine Design	26
4.2	Motion Study	27
4.3	PLC Programming Developing	28
4.4	Cycle Time Analysis	45
4.5	ROI Analysis	46
CHAPTER 5: CONCLUSION AND RECOMMENDATION		47
REFERENCE		49
APPENDIX		50

LIST OF TABLES

1.1: Activities Schedule	3
1.2: Graphical Process Description in Product Assembly Using EK300	7
2.3: Data Collection during Motion Study	16
4.1: Stopwatch Study in Single Cycle of Pen Assembly	46

LIST OF FIGURES

2.1: Flow Chart of Work To produce EK300	5
2.2: Part of EK300	6
2.3: Part of the Machine	6
2.4: Fixture for Pen Assemble Process	10
2.5: Figure 2.5: Fixture of Pen Assembly	10
2.6: Computer Vision during Quality Inspection	12
2.7: Blending System for Concrete Blending Process	12
2.8: Motion in Virtual Reality Box	14
2.9: Piston Motion Study In Solidwork	15
3.1: Flow Chart for Research	18
3.2: Flowchart of Solidwork Motion Study	20
3.3: Flowchart of Developing PLC Ladder Diagram.	21
4.1: Machine Body	22
4.2: Belt	23
4.3: Pulley	23
4.4: Cylinder	24
4.5: Assemble of Machine	24
4.6: First Motion of EK300	25
4.7: Inserting Filter, Plug, Nib and Cap into Body	26
4.8: PLC Programming of Assembly Machine	27
4.9: Simulation of Programming (Switch on)	28
4.10: Simulation of Cylinder 1 (Extract)	29
4.11: Simulation of Cylinder 1 (Fully Extract)	30
4.12: Simulation of Cylinder 1 (Retract)	31
4.13: Simulation of Cylinder 1 (Fully Retract)	32
4.14: Simulation of Cylinder 2(Extract)	33
4.15: Simulation of Cylinder 2(Fully Extract)	34
4.16: Simulation of Cylinder 2 (Retract)	35
4.17: Simulation of Cylinder 2 (Fully Retract)	36
4.18: Simulation of Cylinder 3(Extract)	37

4.19: Simulation of Cylinder 3 (Fully Extract)	38
4.20: Simulation of Cylinder 3 (Retract)	39
4.21: Simulation of Cylinder 3 (Fully Retract)	40
4.22: Simulation of Cylinder 4 (Extract)	41
4.23: Simulation of Cylinder 4 (Fully Extract)	42
4.24: Simulation of Cylinder 4 (Retract)	43
4.25: General Order of EK300 per 6 Month	45

CHAPTER 1

INTRODUCTION

1.1 Introduction

Sparkle Precision Sdn Bhd is a company that manufactures office stationary such as highlight, marker pen and ink. This company main process is shaping plastic using Injection Molding Process. This company also partners with Shachihata (Malaysia) Sdn. Bhd. Sparkle Precision Sdn. Bhd. divides its operation into three departments which are molding department, assembly department and ink department.

One of Sparkle Precision Sdn. Bhd.'s products is pen model EK 300. The manufacturing line to produce this product consists of automated and manual manufacturing cells. The entire line is manned by two operators. Since the assembly line is not fully automated, the output for manual cell of the line is significantly less than that of the automated parts of the manufacturing cell. Because of that, the manual cell becomes the bottleneck of the manufacturing lines causing intermittent stoppage of the automated line. In addition to that, the manual cell also causes high rejection since the pen capping process was in manual approached.

1.2 Problem Statement

The pen assembly line can be divided into automated and manual sections. Ink injected process is fully automated but the pen capping process is manually operated. Since the pen capping process is manually operated, it becomes the bottleneck, causing the upstream automated process need to be stopped intermittently. Due to

this, the operator has to work faster, causing fatigue and carelessness which contributed to high product defects.

1.3 Objective

In order to solve the imbalance between manual and automated sections of the manufacturing lines, the overall aim of this project is to resolve the bottleneck issue at manual capping process. The specific objectives of this project are

- To design the automated capping process
- To simulate the automated capping process
- To perform the ROI analysis of the automated line proposal.

1.4 Scope

The automation system design was carried out for EK300 marker pen capping process at Sparkle Precision Sdn Bhd. The design work included the mechanical, pneumatic, and a PLC ladder diagram. Simulation of the proposed automation system was carried out using Solidworks and CX Programmer.

CHAPTER 2

LITERITURE REVIEW

This chapter provides the basic knowledge for the project finding by researchers and the methodology used by other researchers was summarized. This chapter also includes a SPSB background.

2.1 Company Background

SPSB was established on 20 August 1996 with factory area of 3000 sq ft. It operates at Teaching Factory, Industrial Center Park, UTM. Teaching Factory is a zone for manufacturing or business operations, which is being nurtured through entrepreneurial development programs. It acts as a source base to firm and institution for technology transfer. The 'hands on' short term programs conducted also aimed to address current and future skilled labor shortage in the industries. UTM Teaching Factory was established under the Techno Skill Program funded by Ministry Youth & Sport Malaysia. The core actions are injection of plastic components, provide a technical assistant service to industry and skills training center.

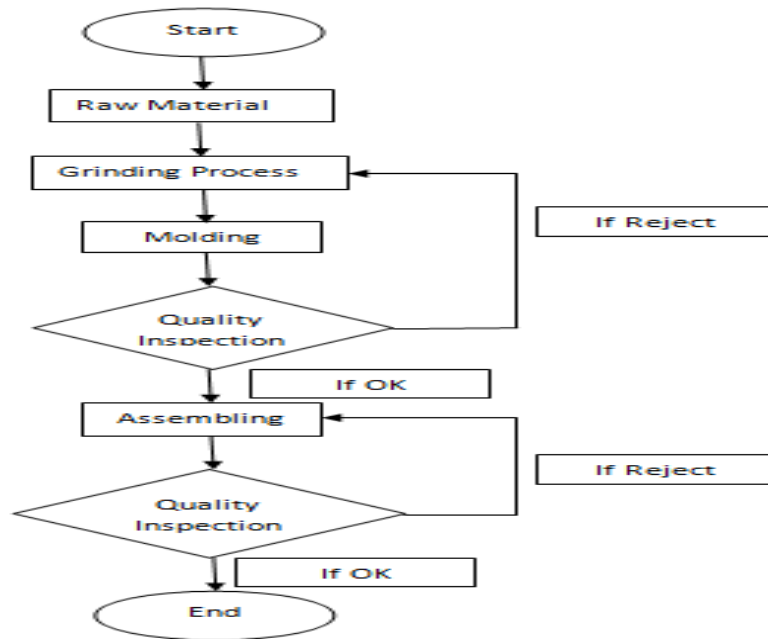

Figure 2.1: Flow Chart of Work To produce EK300

Figure 2.1 shows the process for EK300. During the manufacturing and assembling process, quality inspections were done twice in order to make sure that the marker pens produced are of high quality and fulfill customer requirement. In assembly team, a multiple sub process was involved in order to produce EK300. All process has a standard procedure to prevent unsystematic work flow and decrease reject.

2.2 Assembling Process of EK300

EK300 is a marker pen designed by Shachihata (M) Sdn Bhd. Some of the assembling process utilized automated machine in order to increase productivity and reduce manual labor dependency.

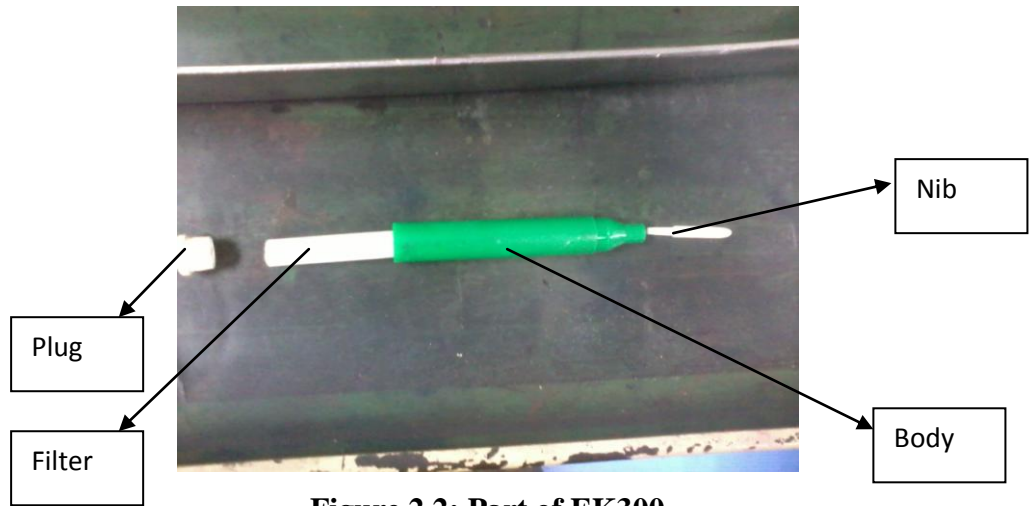

Figure 2.2: Part of EK300

Figure 2.2 shows six components of EK300 product. All the components were assembled using the automated assembling machine. The automated assembly station assembles plug, filter and nib to the body of the marker pen. The capping process utilizes manual system.

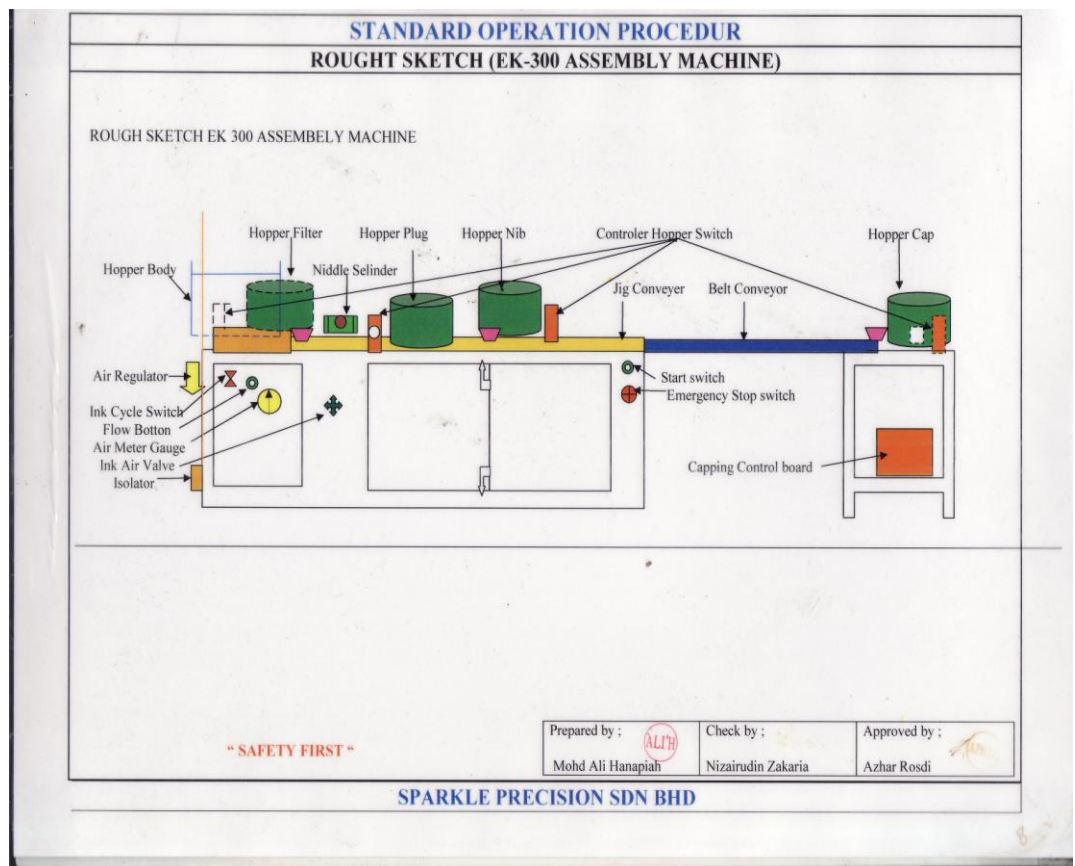



Figure 2.3: Part of the Machine

Figure 2.3 shows a layout of EK300 assembly line. Hopper body is used as a body storing part. Conveyor duty is to be transported body from one process to another process. Hopper nib, plug, filter and cap are used to storing each part based on their part. Automated assembly machine is utilized up to the nib assembly only. The capping process is manually done.

Table 2.1: Graphical Process Description in Product Assembly Using EK300

Figure	Procedure
	<p>Pen body in machines hopper. This process is fully automated system.</p>
	<p>Body transports to filter and nib assembler to assembling that part. This process is fully automated system</p>





Body transports to the plug by conveyor.

This is fully automated system



Body transports to cap operator.

This is fully automated system.

	<p>Cap assemblies by operator. This is a fully manual system.</p>
	<p>EK300 ready for packing and send to the customer.</p>

2.3 Approaches in Capping Process Implementation.

This review summarized studies on capping process implementation in manual and automated mode for various products in relation to this research. Journal and article from another researcher were studied in order to identify possible approach that can be adopted for this research.

Andrew D. (2008) studied to the assembly of pen parts using semi automated system. This device used electric motor energy to move the cylinder to assemble the pen parts. In the proposed procedure pen parts were placed at the locator manually by operator as shown in Figure 2.4 shows the design of the semi-automated system for

the pen assembly process. The locator has a fool proving design for preventing orientation mistake by the operator.

According to Andrew D. (2008), the method to assemble pen parts is using semi automated system. This device uses electrical energy to move the cylinder to assemble the pen parts. The manual procedure in this method is all pen parts need to place at the locator by the operator.

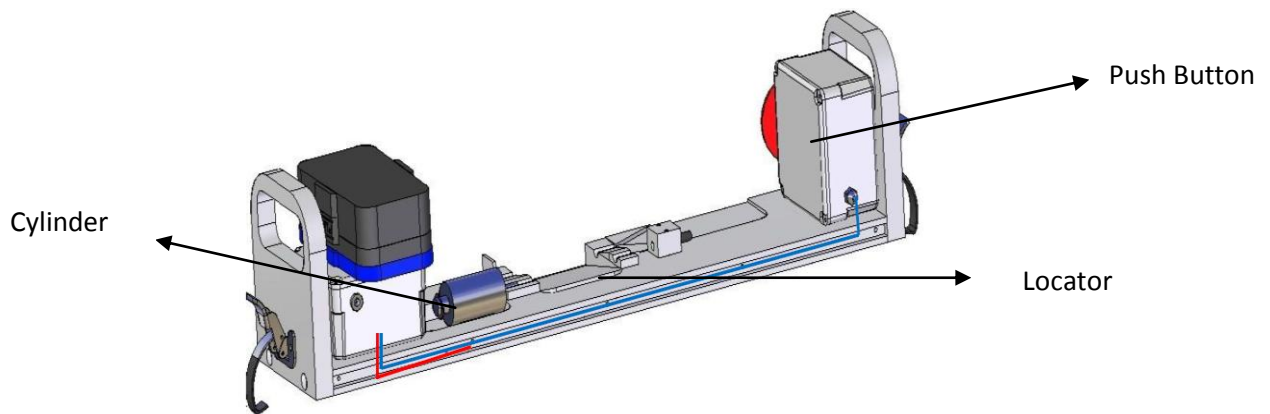

Figure 2.4: Fixture for Pen Assemble Process (Andrew, 2008)

Bella V. (2009) studied a manual assembly of the pen using special fixtures as shown in Figure 2.5.

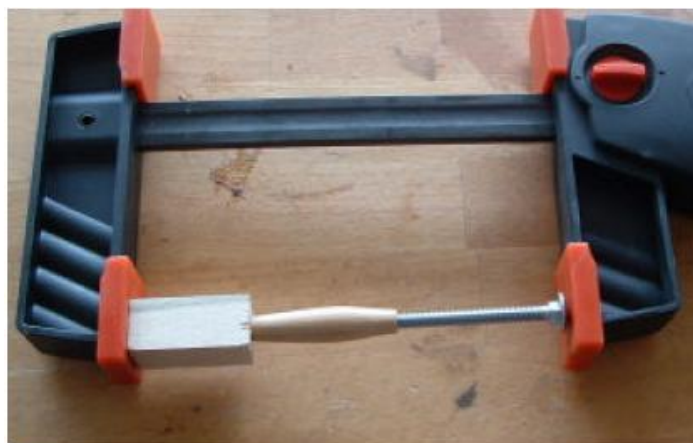

Figure 2.5: Fixture of Pen Assembly (Bella, 2009)

Figure 2.5 shows the fixture of pen assembly by Bella V. This fixture was designed with locator and fool proving to prevent the operator place the pen in the wrong orientation.

Jeremy L.Z. (2008) studied a fully automated system by inserting ink in cartridge processing. Based on time study done after the implementation of the automation system, output for ink cartridge insertion process improved by 64 units per minute. The automated system has been designed using components such as sensor, cylinder, coil relay and limit switch.

2.3.1 Summary of Capping Process Implementation

After studying a journal and paper base on time study, the automated system was selected in order to fulfil the objective of this research. The automated system can increase the output of the capping assembly process.

2.4 Approaches in Automation Implementation

According to Groover P.M. (2008), automated can be explained by some system that can run the process or procedure without human assistance. Automated technology can be divided by 3 types which is numerical control, robotic technology and programmable logic controller.

According to Gunasekaran, S. (2005), robotic system for the food industry is good for mass production and prevents the chemical exposed. Robotic system was improved quality of the product, output and safety of operator. Since the robotic system is used, the huge cost and highly skilled operator are needed.

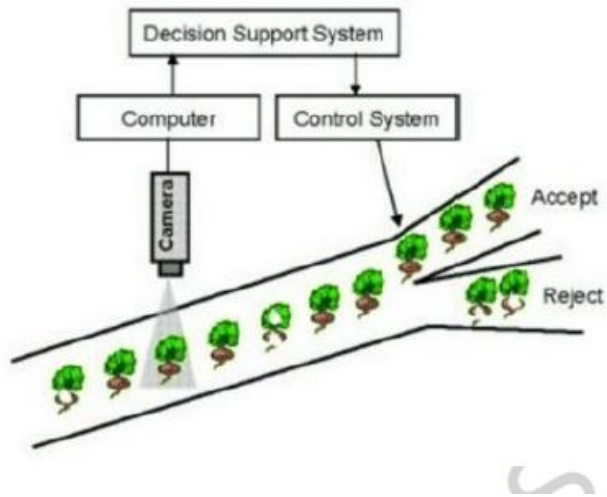

Figure 2.6: Computer Vision during Quality Inspection (Gunasekaran , 2005)

Figure 2.6 shows a computer vision during quality inspection in the quality inspection process. It uses computer vision to inspect a reject of the product. This method is useful in a mass production process.

According to Keviczky L. (2009), Mixer of concrete material can be developed by using Programmable Logic Control (PLC). It was used FPWin Pro software to create and testing the PLC ladder diagram. The PLC ladder diagram has been developed for data collection and truth table. This method is good, but it needs a programmer and software to fulfil the perfect PLC system.

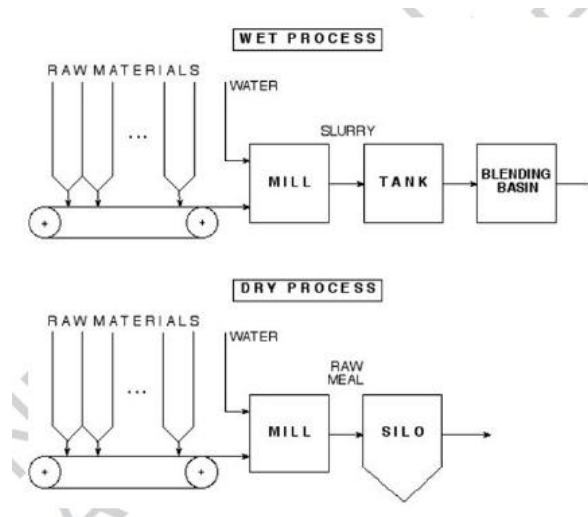

Figure 2.7: Blending System for Concrete Blending Process (Keviczky, 2009)

Figure 2.7 shows about blending system for the concrete blending process. It uses a conveyor as transporting material. All process is controlled by PLC system. Since all process is automated system, 3 operators need to control the process.

According to James M. (2007), semiconductor can be manufactured perfectly by using a computer integrated manufacturing system (CIM). This system was used a CNC system where CNC system will control the movement of the machine. This system is suitable for accuracy of dimension and mass production is a main issue for certain process.

2.4.1 Summary of Automation review

Possible method in automation implementation is to use programmable logic control (PLC). The PLC ladder diagram can be created by using suitable software such as automation studio software.