



**UNIVERSITI TEKNIKAL MALAYSIA MELAKA**

**SINGLE-PHASE CASCADED H-BRIDGE MULTILEVEL  
INVERTER**

This report submitted in accordance with requirement of the Universiti Teknikal  
Malaysia Melaka (UTeM) for the Bachelor Degree in Electrical Engineering  
Technology (Industrial Power) (Hons)

by

**SAIFULLAH AIZZAT BIN ABDULLAH**

**B071110189**

**900419145027**

FACULTY OF ENGINEERING TECHNOLOGY

2015

## **DECLARATION**

I hereby, declared this report entitled “Single-Phase Cascaded H-Bridge Multilevel Inverter” is the results of my own research except as cited in references.

**Signature** : .....

**Name** : **SAIFULLAH AIZZAT BIN ABDULLAH**

**Date** : **28th JANUARY 2015**

## **APPROVAL**

This report is submitted to the Faculty of Engineering Technology of UTeM as a partial fulfillment of the requirements for the degree of Bachelor of Electrical Engineering Technology (Industrial Power) with Honours. The member of the supervisory committee is as follow:

.....

(Project Supervisor)

## ABSTRAK

Teknologi penyongsang berbilang telah banyak digunakan baru-baru ini dalam aplikasi yang menggunakan tenaga yang boleh diperbaharui dan industri sebagai alternatif yang sangat penting dalam bidang kuasa tinggi dan tinggi. Pada asasnya, penyongsang adalah alat elektronik kuasa yang menukarkan arus terus (DC) kepada arus ulang-alik (AC) namun tidak sesuai digunakan untuk bidang kuasa tinggi dan voltan tinggi. Terdapat beberapa jenis penyongsang bertingkat (MLI) seperti penyongsang bertingkat H-Bridge, kapasitor diapit penyongsang bertingkat dan diod diapit penyongsang bertingkat. Tujuan projek ini adalah untuk mengkaji penyongsang bertingkat H-Bridge pada satu fasa. Dengan menggunakan MOSFET sebagai komponen pensuisan dan menggunakan modulasi lebar denyut (PWM) kaedah kawalan untuk menghasilkan output yang dikehendaki iaitu lima tingkat. Kawalan kod dan simulasi dilakukan dengan menggunakan MATLAB. Penyongsang berbilang digunakan secara meluas dalam, tenaga solar dan lain-lain tenaga boleh diperbaharui.

## **ABSTRACT**

Multilevel inverter technology has been known recently in renewable and industrial applications for high-power and high-voltage energy control. Basically, an inverter is an electronic device that converts a direct current (DC) to alternating current (AC) but not suitable for high voltage and high power application. There are a few types of multilevel inverter (MLI) such as a cascaded H-bridge multilevel inverter, a capacitor clamped multilevel inverter and a diode clamped multilevel inverter. The purpose of the project is to study a single phase cascaded H-bridge multilevel inverter. By using MOSFET as the switching component and using pulse width modulation (PWM) control method to produce the desired output that is 5-level output. The coding control and simulation is done by using MATLAB. Multilevel inverter are widely used in, photovoltaic and others renewable energy.

# DEDICATION

Specially dedicated to my beloved family

## **ACKNOWLEDGEMENT**

First and foremost, I would like to express my gratitude towards Allah SWT for his blessing to give me strength in mentally and physically to do my bachelor degree project. Secondly, I would like to express my gratitude to my supervisor, Ms Suziana Binti Ahmad for her valuable guidance and relentless help during this project, without her help this project will not complete. My gratitude also to other lecturers that help me relentlessly and to faculty that give me everything I need to complete this project. I would like to thank my family for their endless support for my project. Lastly I would like to express my gratitude to fellow friend that help me completing this project. Without all the support and help from all the people mention above this project will not be completed.

# TABLE OF CONTENT

DECLARATION	ii
APPROVAL	iii
ABSTRAK	iv
ABSTRACT	v
DEDICATION	vi
ACKNOWLEDGEMENT	vii
TABLE OF CONTENT	viii
LIST OF FIGURES	xi
LIST OF TABLE	xiii
LIST OF ABBREVIATIONS	xiv
<b>CHAPTER 1 : INTRODUCTION</b>	<b>1</b>
1.1 Introduction	1
1.2 Background	2
1.3 Problem Statement	2
1.4 Objectives	3
1.5 Scope of work	3
1.6 Report outline	4



<b>CHAPTER 2 : LITERATURE REVIEW</b>	5
2.1    Introduction	5
2.2    Multilevel Inverter	5
2.3    AC and DC Differences	7
2.4    Cascaded H-bridge Multilevel Inverter	7
2.5    Capacitor Clamped Multilevel Inverter	9
2.6    Diode Clamped Multilevel Inverter	10
2.7    Switching Devices	11
2.8    Pulse Width Modulation (PWM)	13
2.9    Total Harmonic Distortion (THD)	14
2.10   Related Previous Works	15
<b>CHAPTER 3 : METHODOLOGY</b>	18
3.1    Introduction	18
3.2    Flowchart	19
3.3    Project Gantt Chart	21
3.4    Simulation Approach	23
3.4.1  MATLAB/SIMULINK	23
3.4.2  Proteus	25
3.4.3  Code Composer Studio (CCS)	26
3.5    Hardware Implementation	27
3.5.1  Etching Process	27
3.5.2  Soldering Process	31

3.5.3	Driver	32
3.5.4	Checking Connection	32
3.6	Bill of Material	33
3.7	Summary	33
<b>CHAPTER 4 : RESULT AND DISCUSSION</b>		<b>34</b>
4.1	Introduction	34
4.2	Simulation Result	34
4.2.1	MATLAB/SIMULINK	35
4.2.2	THD Comparison	37
4.2.3	Code Composer Studio	37
4.3	Hardware Development Results	38
4.4	Discussion Result	42
<b>CHAPTER 5 : CONCLUSION</b>		<b>43</b>
5.1	Conclusion	43
5.2	Summary of Project	44
5.3	Problems Faced During Project	44
5.4	Future Work	45
5.5	Commercialization	45
<b>APPENDICES</b>		<b>46</b>
<b>REFERENCES</b>		<b>50</b>

## LIST OF FIGURES

2.1	Output for 5-level multilevel inverter	6
2.2	DC AC waveform	7
2.3	Cascaded H-bridge Multilevel Inverter (Tahri et al. n.d.)	8
2.4	Capacitor Clamped Multilevel Inverter (Maheshkumar et al. 2013)	9
2.5	Diode Clamped Multilevel Inverter (Vol- & Engineering 2014)	10
2.6	a) MOSFET b) IGBT c) Diode	11
2.7	Comparison of 500V IGBT and MOSFET	12
2.8	Type of MOSFET	13
2.9	PWM	13
2.10	5-level PWM (Nurul 2012)	16
2.11	7-level PWM (Nurul 2012)	16
2.12	5-level Output (Nurul 2012)	17
2.13	7-level Output (Nurul 2012)	17
3.1	Flowchart of the Project	19
3.2	5-level cascaded H-bridge MLI	23
3.3	9-level cascaded H-bridge MLI	24
3.4	Proteus connection for 5-level	25
3.5	Connection of PCB	25
3.6	3D PCB connection	26
3.7	CCS microcontroller	26
3.8	Printed circuit on trace paper	27

3.9	UV curing process	28
3.10	PCB Developer process	28
3.11	Cleaning process	29
3.12	Photoresist Stripper	29
3.13	Drilling Process	30
3.14	PCB etching completed	30
3.15	MOSFET soldering process	31
3.16	Complete solder circuit	31
3.17	Complete solder circuit (component)	31
3.18	Driver MOSFET	32
4.1	PWM output	35
4.2	5-level Output with PWM	35
4.3	5-level output	36
4.4	9-level output	36
4.5	CCS configuration	37
4.6	MOSFET	38
4.7	MOSFET testing	38
4.8	MOSFET output waveform	39
4.9	MOSFET driver	39
4.10	Output waveform for driver	40
4.11	5-level Cascaded H-bridge with driver	40
4.12	Input source for MOSFET	41
4.13	Input source for Driver	41
4.14	5-level cascaded H-bridge Output waveform	42

## LIST OF TABLE

2.1	Comparison between Topology for THD and Component	14
2.2	5-level Switching Operations	15
2.3	7-level Switching Operation	15
2.4	Comparison between 5-level and 7-level	17
3.1	Project Gantt Chart	22
3.2	Budget for 5-level cascaded H-bridge MLI	33

## **LIST OF ABBREVIATIONS**

IGBT – Insulated Gated Bipolar Transistor

THD – Total Harmonic Distortion

MOSFET – Metal Oxide Semiconductor Field Effect Transistor

PWM – Pulse Width Modulation

AC – Alternating Current

DC – Direct Current

MLI – Multilevel Inverter

CHB - Cascaded H-Bridge

CCS – Code Composer Studio

PCB – Printed Circuit Board

# CHAPTER 1

## INTRODUCTION

### 1.1 Introduction

The electrical charges that are caused by physical phenomenon are called electricity and these charges produces electromagnetic fields where by it acts on another charges. The study of electricity and magnetism was first brought upon our knowledge in the year 1600 by a scientist named William Gilbert. Later, an extensive researched done Benjamin Franklin in the year 1752 through the act flying a kite during a stormy and lightning day. The lightning strike the kite and it was then discovered that lightning produces electrical charges that made up of positive and negative charge.

The innovation of electricity has brought upon to many advancement. For example, nowadays, electrical charges can be from the renewable energy and direct current can be inverted into alternating current. Renewable energy are natural resources that are capable of generating electricity for example the wind turbine, solar panel, hydroelectric and so forth. Direct current (DC) is a current that flow in a single direction. DC is impractical when it comes to changing the voltage from high to low or conversely. Alternating current is suitable for high voltage transmission. A power inverter is a device that capable of converting a direct current to standard alternating current.

## **1.2 Background**

This project is done to study a single phase cascaded H-Bridge multilevel inverter for 5-level output. Multilevel inverter is the source of high power, often used in industrial applications and can use either sine waves or modified sine waves. The project involves inverter consists of four H-bridge inverters that are cascaded in arrangement. For a 5-level cascaded H-bridge multilevel inverter, 8 switching devices are needed. For this project pulse width modulation (PWM) will be used as a control method. MOSFET is used as switches because of low power consumption and dissipation. The main objective is to study the single-phase cascaded multilevel inverter for 5-level.

## **1.3 Problem Statement**

Nowadays, industrial applications shows a significant increase in the usage of high voltage and high power. Implementation of two level inverter is not suitable for high voltage and high power conditions and to overcome this problem multilevel inverter is utilized. This study is motivated by several problems which are the less efficiency, high cost, and high switching losses of other types of inverter. Besides, this project is driven by the high efficiency and low switching losses on multilevel inverter. On the other hand, this project is prompted by the low total harmonic distortion (THD) of cascaded H bridge multilevel inverter in comparing to other multilevel inverter.



## **1.4 Objectives**

Based on the problem statement above, this study is motivated by the following objectives which are:

- i. To study a single phase cascaded H-bridge multilevel inverter.
- ii. To simulate a proposed topology using MATLAB/Simulink
- iii. To implement a hardware for a proposed topology

## **1.5 Scope of work**

A project will cover the scope of implementing hardware on circuit that utilize cascaded H bridge multilevel inverter to convert direct current to alternating current. This project can be divided into several stages or steps. Firstly, this study involve the understanding of various type of inverter and multilevel inverter focusing on the cascaded H bridge multilevel inverter. Besides, before implementing the proposed topology, it is important to study about switching especially the MOSFET as switches. Then, pulse width modulation (PWM) control method to produce the desired output that is five level output. Secondly, the MOSFET and PWM simulation and coding control are done using MATLAB. Lastly, the implementation of hardware are been tested.

The limitations of this project are the hardware implementation of the proposed topology is costly due to complexity in assembling the circuit. Other than that, this project requires a long duration of time due to the time taken in understanding the design of proposed topology and the time taken in learning the simulation using MATLAB.

## 1.6 Report outline

This documented thesis consist of five chapters. The first chapter of this thesis is Introduction which covers the project background, problem statements and the objectives of this project. The scope of study and report outline are also included in this chapter.

The second chapter of this thesis is Literature Review which focuses on reviewing previous researches or works that relates to the scope of this study. This chapter review on the implementation of various inverter and multilevel inverter for example a cascaded H-bridge multilevel inverter, a capacitor clamped multilevel inverter and a diode clamped multilevel inverter. Besides that, this chapter reviews on different type of switching devices which are insulated gated bipolar transistor (IGBT) and metal oxide semiconductor field effect transistor (MOSFET).

The third chapter of this thesis is the Research Methodology elaborates in detail of the procedures and steps taken in conducting the experiment of this project. Design and simulation software which are used to complete this project also explained in this chapter.

The fourth chapter of this thesis is Result and Discussion. This chapter discusses about the result from the five level output of the single phase cascaded H bridge multilevel inverter. The structure and setup of the cascaded H bridge multilevel inverter that uses 8 switches will also be discussed.

Lastly, the fifth chapter of this thesis is the Conclusion. This chapter will discuss on conclusion of the project by analyse the result in chapter four. Also, this chapter will give suggestions and recommendations for future works. The next section of this thesis is Chapter 2, Literature Review.

## **CHAPTER 2**

### **LITERATURE REVIEW**

#### **2.1 Introduction**

This chapter will be discussing about the overview of multilevel inverter including 2-level inverter. Mainly about cascaded H-bridge multilevel inverter, capacitor clamped multilevel inverter, diode clamped multilevel inverter and their switching devices and related result by other research will also be discussed.

#### **2.2 Multilevel Inverter**

Inverter is an electronic device that is functioned to convert direct current (DC) to alternating current (AC). An input, output voltage and frequency depend on the design of the circuit. There are two types of inverter which are voltage source inverter and current source inverter. Normal inverter also known as two-level inverter that is different with multilevel inverter. Inverter is less efficiency, high in total harmonic distortion (THD) and high switching losses. Two-level inverter is not suitable for high voltage and high power application. This is the main reason why multilevel inverter is widely used in high voltage application (Orfanoudakis et al. 2010). Multilevel inverter is used to convert direct current (DC) to alternating current (AC). The function of multilevel inverter is same as two level inverter but

this type inverter can be used in high power and high voltage application because of its efficiency, low in total harmonic distortion (THD) and low in switching losses (Orfanoudakis et al. 2010). Multilevel inverter means that the inverter have more than two level such as 3 level, 5 level, 9 level and 11 level compare to normal inverter that only have two level. There are many different topologies to build a multilevel inverter. The one that have been proposed for this project is a cascaded H-bridge multilevel inverter (Tahri et al. n.d.). Others topology is a capacitor clamped multilevel inverter also known as a flying capacitor multilevel inverter and a diode clamped multilevel inverter (Vol- & Engineering 2014). The three topologies are widely used in high power application because of low switching losses and low in THD (Multilevel n.d.). Study by previous works show that cascaded H-bridge multilevel inverter is the best option for medium voltage and high power application due to the lowest THD among others topology (Inverter & Booma 2011). Figure 2.1 shows an output for 5-level multilevel inverter.

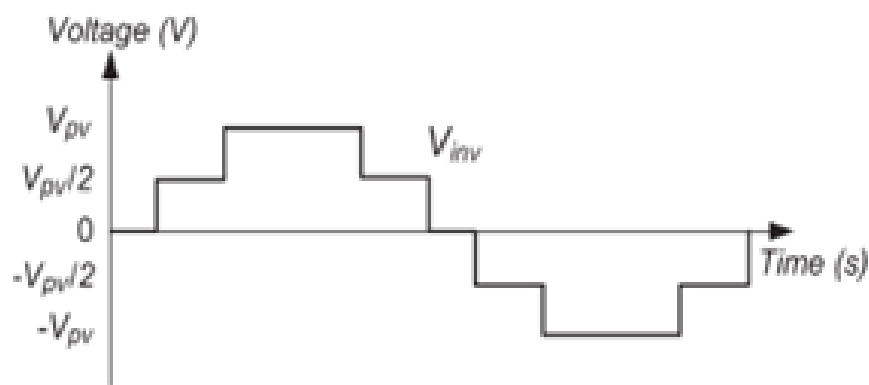

Figure 2.1 Output for 5-level multilevel inverter

### 2.3 AC and DC Differences

The device use to convert direct current (DC) to alternating current (AC) is inverter. To know the concept of inverter firstly the understanding of AC/DC is important. Current that move in one direction is called direct current (DC) while current that can change direction in positive cycle or negative cycle is called alternating current (AC). This project is to build an electronic device that can convert DC to AC for high voltage and high power application. Figure 2.2 shows a DC AC waveform.

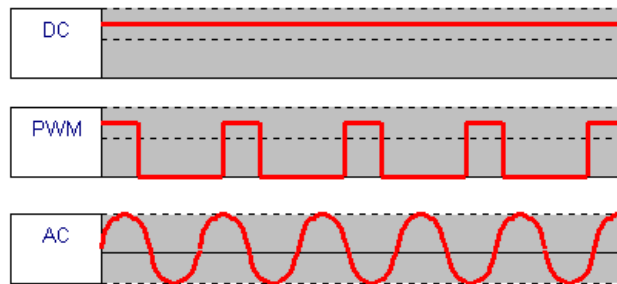

Figure 2.2: DC AC waveform

### 2.4 Cascaded H-bridge Multilevel Inverter

Cascaded H-bridge multilevel inverter is the simplest multilevel inverter compare to other multilevel inverter (Tahri et al. n.d.). This multilevel inverter contain of H-bridges connected in series that has a separate DC source that can produce a desired output voltage. The Dc source can be from solar cells, wind turbine or battery. This make cascaded H-bridge popular for renewable energy because of separate DC sources. (Tahri et al. n.d.) Figure 2.3 show 5 level cascaded H-bridge multilevel inverter circuit.

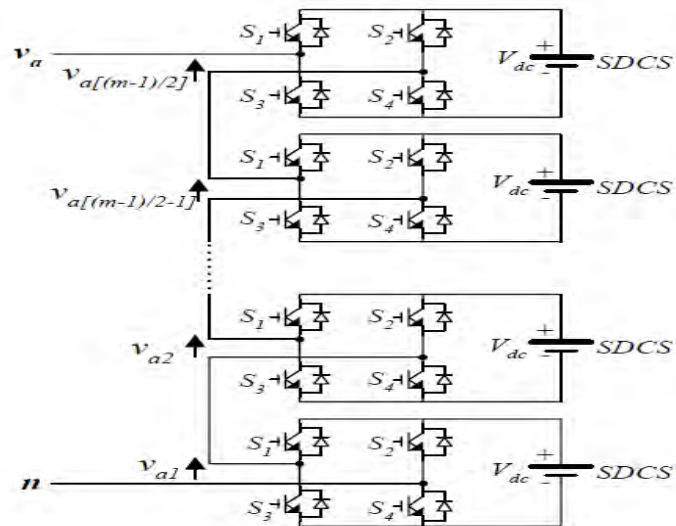

Figure 2.3: Cascaded H-bridge Multilevel Inverter (Tahri et al. n.d.)

Advantages:

- Lowest in component used
- Lowest in total harmonic distortion (THD) (Lokeshwari 2014)
- Simple circuit
- Voltage stress is reduce
- Transformer less
- Not expensive compare to other multilevel inverter.

Disadvantages:

- Separated DC sources.
- Not suitable for certain application.

## 2.5 Capacitor Clamped Multilevel Inverter

Flying capacitor multilevel inverter also known as capacitor clamped multilevel inverter this is because of its independent capacitor clamped the voltage to another capacitor voltage level (Maheshkumar et al. 2013). If the output level needed is high, the amount of capacitor used also increase. Figure 2.4 show the capacitor clamped multilevel inverter circuit.

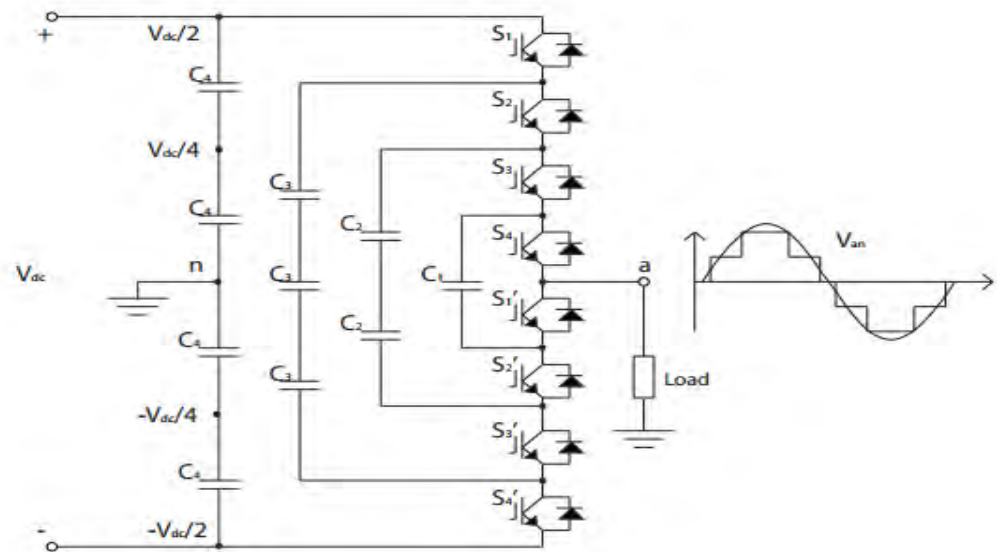

Figure 2.4: Capacitor Clamped Multilevel Inverter (Maheshkumar et al. 2013)

Advantages:

- real and reactive power flow can be control
- get the desired voltage value by using capacitor.

Disadvantages:

- complicated to control compare to other topology
- For real power transmission the switching and efficiency is very poor
- Expensive compare to other topology.

## 2.6 Diode Clamped Multilevel Inverter

Diode clamped multilevel inverter is using diode as the main component. The use of the diode is to clamp the dc bus voltage for level output voltage. The main function of diodes is to limit the power devices voltage stress. Figure 2.5 show the diode clamped multilevel inverter circuit.

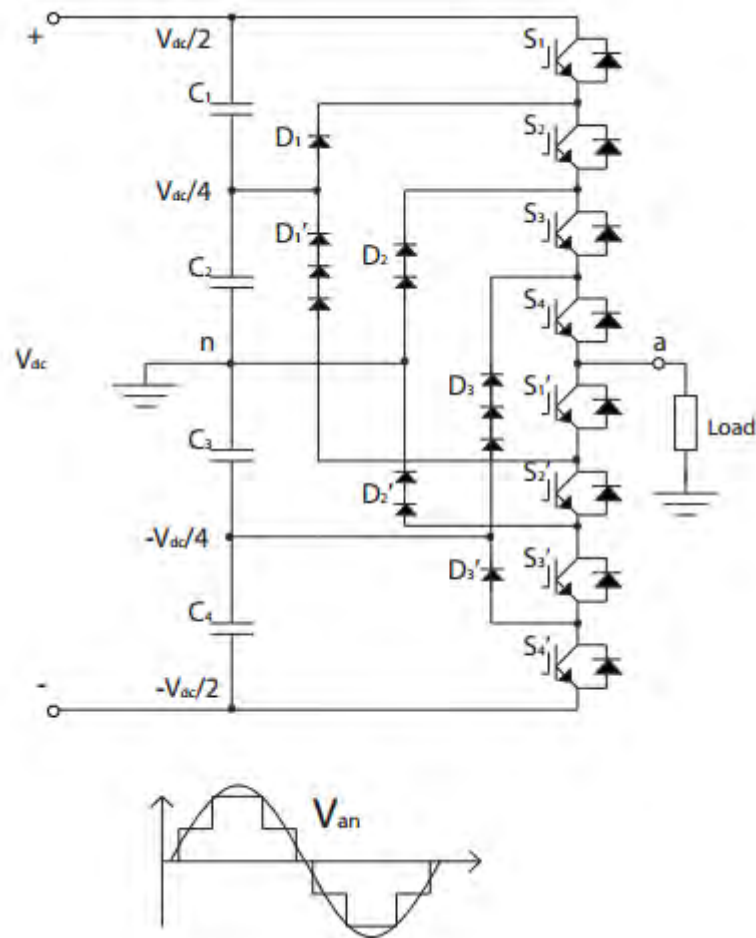

Figure 2.5: Diode Clamped Multilevel Inverter (Vol- & Engineering 2014)